

# Seat-belts and child restraints

---

A ROAD SAFETY MANUAL  
FOR DECISION-MAKERS  
AND PRACTITIONERS



Seat-belts and child restraints: a road safety manual for decision-makers and practitioners

ISBN

Suggested citation:

Seat-belts and child restraints: a road safety manual for decision-makers and practitioners  
London, FIA Foundation for the Automobile and Society, 2009

© FIA Foundation for the Automobile and Society.

Publications of the FIA Foundation for the Automobile and Society (FIA Foundation) can be obtained from [www.fiafoundation.org](http://www.fiafoundation.org)

Permission to reproduce or translate FIA Foundation publications – whether for sale or for non-commercial distribution – should be addressed to:

FIA Foundation  
60 Trafalgar Square  
London WC2N 5DS  
United Kingdom  
Email: [mail@fiafoundation.org](mailto:mail@fiafoundation.org)

The designations employed and the presentation of the material in this publication do not imply the expression of any opinion whatsoever on the part of the FIA Foundation for the Automobile and Society (FIA Foundation), the World Health Organization (WHO), the Global Road Safety Partnership (GRSP) and the World Bank concerning the legal status of any country, territory, city or area or of its authorities, or concerning the delimitation of its frontiers or boundaries. Dotted lines on maps represent approximate border lines for which there may not yet be full agreement.

The mention of specific companies or of certain manufacturers' products does not imply that they are endorsed or recommended by the FIA Foundation, the WHO, the GRSP or the World Bank in preference to others of a similar nature that are not mentioned. Errors and omissions excepted, the names of proprietary products are distinguished by initial capital letters.

All reasonable precautions have been taken by the FIA Foundation, the WHO, the GRSP and the World Bank and the authors to verify the information contained in this publication. However, the published material is being distributed without warranty of any kind, either express or implied. The responsibility for the interpretation and use of the material lies with the reader. In no event shall the FIA Foundation, the WHO, the GRSP and the World Bank or the authors be liable for damages arising from its use.

Initial design by Inis Communication: [www.inis.ie](http://www.inis.ie)

# Seat-belts and child restraints

---

A road safety manual for  
decision-makers and  
practitioners



Seat-belts and child restraints: a road safety manual for decision-makers and practitioners

ISBN 978-0-9561403-0-2

Suggested citation:

*Seat-belts and child restraints: a road safety manual for decision-makers and practitioners*  
London, FIA Foundation for the Automobile and Society, 2009

© **FIA Foundation for the Automobile and Society.**

Publications of the FIA Foundation for the Automobile and Society (FIA Foundation) can be obtained from [www.fiafoundation.org](http://www.fiafoundation.org)

Permission to reproduce or translate FIA Foundation publications – whether for sale or for non-commercial distribution – should be addressed to:

FIA Foundation  
60 Trafalgar Square  
London WC2N 5DS  
United Kingdom  
Email: [mail@fiafoundation.org](mailto:mail@fiafoundation.org)

The designations employed and the presentation of the material in this publication do not imply the expression of any opinion whatsoever on the part of the FIA Foundation for the Automobile and Society (FIA Foundation), the World Health Organization (WHO), the Global Road Safety Partnership (GRSP) and the World Bank concerning the legal status of any country, territory, city or area or of its authorities, or concerning the delimitation of its frontiers or boundaries. Dotted lines on maps represent approximate border lines for which there may not yet be full agreement.

The mention of specific companies or of certain manufacturers' products does not imply that they are endorsed or recommended by the FIA Foundation, the WHO, the GRSP or the World Bank in preference to others of a similar nature that are not mentioned. Errors and omissions excepted, the names of proprietary products are distinguished by initial capital letters.

All reasonable precautions have been taken by the FIA Foundation, the WHO, the GRSP and the World Bank and the authors to verify the information contained in this publication. However, the published material is being distributed without warranty of any kind, either express or implied. The responsibility for the interpretation and use of the material lies with the reader. In no event shall the FIA Foundation, the WHO, the GRSP and the World Bank or the authors be liable for damages arising from its use.

Editing and inside design by Inís Communication: [www.inis.ie](http://www.inis.ie)

# Table of contents

Preface . . . . .	ix
Contributors and acknowledgements . . . . .	xi
Executive summary . . . . .	xiii
<hr/>	
<b>Introduction . . . . .</b>	<b>xv</b>
Background to the series of manuals . . . . .	xvii
Background to the seat-belt and child restraint manual . . . . .	xix
Why was the seat-belt and child restraint manual developed? . . . . .	xix
Who is the manual for? . . . . .	xix
What does this manual cover and how should it be used? . . . . .	xx
How was the manual developed? . . . . .	xxii
Dissemination of the manual . . . . .	xxiii
How to get more copies . . . . .	xxiii
Reference . . . . .	xxiv
<hr/>	
<b>1. The need for seat-belts and child restraints . . . . .</b>	<b>1</b>
1.1 Road traffic death and injury as a worldwide public health problem . . . . .	3
1.1.1 Worldwide trends in road traffic death and injury . . . . .	3
1.1.2 Types of injuries sustained by vehicle occupants . . . . .	5
1.2 How seat-belts and child restraints prevent or minimize injury . . . . .	6
1.2.1 What happens in a crash? . . . . .	6
1.2.2 How a seat-belt works . . . . .	7
1.2.3 How a child restraint works . . . . .	7
1.3 Recommended types of seat-belts and child restraints . . . . .	8
1.3.1 Seat-belt design . . . . .	8
1.3.2 Types of child restraints . . . . .	9
1.4 Effectiveness of seat-belt and child restraint use in preventing death and reducing injury . . . . .	12
1.4.1 Effectiveness of seat-belts . . . . .	12

1.4.2 Effectiveness of child restraints . . . . .	15
1.4.3 Seat-belt wearing rates . . . . .	16
1.4.4 Child restraint use rates . . . . .	19
1.5 Effectiveness of seat-belt and child restraint programmes at increasing wearing rates by vehicle occupants . . . . .	19
Summary . . . . .	22
References . . . . .	23

---

## **2. How to assess the situation in a particular country . . . . .**

2.1 The need to assess the current situation . . . . .	27
2.1.1 Understanding the current situation through baseline data collection . . . . .	27
2.1.2 Quality of the data . . . . .	29
2.2 How to assess the extent of the problem of non-use of seat-belts and child restraints . . . . .	29
2.2.1 Assessing the extent of the vehicle occupant injury problem . . . . .	30
2.2.2 What are the seat-belt and child restraint wearing rates in the area being considered? . . . . .	35
2.2.3 Why do people not wear seat-belts and use child restraints? . . . . .	40
2.3 How to assess what is already in place . . . . .	46
2.3.1 Who is in charge of road safety, and what funds are there for it? . . . . .	46
2.3.2 Who are the stakeholders? . . . . .	48
2.3.3 Is there a seat-belt use law in place? . . . . .	49
2.3.4 Is there a seat-belt and child restraint standard in place? . . . . .	51
2.3.5 Have any seat-belt and child restraint programmes been attempted so far? . . . . .	51
2.3.6 Using the situational assessment to prioritize actions . . . . .	53
Summary . . . . .	53
References . . . . .	54

---

## **3. How to plan and manage a seat-belt programme . . . . .**

3.1 How to establish a working group . . . . .	57
3.1.1 Who to involve? . . . . .	58
3.1.2 Assigning roles to working group members . . . . .	59
3.2 How to prepare and promote an action plan . . . . .	61
3.2.1 Setting the programme's objectives . . . . .	61

3.2.2	Setting targets	62
3.2.3	Choosing performance indicators	63
3.2.4	Deciding on activities	64
3.2.5	Setting a time frame and phasing the programme	64
3.2.6	Estimating resource needs	69
3.2.7	Setting up a monitoring mechanism	72
3.2.8	Ensuring sustainability of the programme	73
	Summary	74
	References	75
<hr/>		
<b>4.</b>	<b>How to develop and implement interventions</b>	<b>77</b>
4.1	Increasing usage: the combined approach	81
4.2	Legislation and penalties	82
4.2.1	Developing seat-belt fitting and usage laws	83
4.2.2	Identifying legal responsibilities	86
4.2.3	Exemptions	86
4.2.4	Penalties for non-compliance	87
4.2.5	Developing and implementing legislation	89
4.2.6	Phasing implementation	91
4.2.7	Section summary: checklist for seat-belt legislation	92
4.3	Seat-belt standards and equipment	93
4.3.1	Adopting a standard or regulation	94
4.3.2	Types of standards or regulations and their content	97
4.3.3	Testing and certification	98
4.3.4	Vehicle inspection and seat-belt maintenance	99
4.3.5	Retrospective fitting	100
4.3.6	In-vehicle reminder systems	102
4.3.7	Section summary: checklist for developing seat-belt standard or regulation	103
4.4	Increasing usage: enforcement	104
4.4.1	Pre-requirements	104
4.4.2	Enforcement strategy	105
4.4.3	Enforcement methods	108
4.4.4	Police training	109
4.4.5	Processing penalties	109
4.4.6	Overcoming obstacles to enforcement	110
4.4.7	Section summary: increasing seat-belt usage through enforcement	111

4.5	Increasing usage: voluntary measures . . . . .	112
4.6	Increasing usage: publicity campaigns . . . . .	113
4.6.1	Objectives of the campaign . . . . .	115
4.6.2	Creating campaign messages . . . . .	116
4.6.3	Reaching the target audience . . . . .	118
4.6.4	Creative concepts . . . . .	119
4.6.5	Selecting an agency for the campaign . . . . .	122
4.6.6	Working with the media . . . . .	124
4.6.7	Campaign stages in relation to seat-belt legislation . . . . .	124
4.6.8	Evaluating the campaign . . . . .	126
4.7	Increasing usage: other voluntary measures . . . . .	127
4.7.1	Employer regulation and incentive schemes . . . . .	127
4.7.2	Education and training . . . . .	129
4.7.3	Insurance and public incentive schemes . . . . .	132
4.8	How to ensure an appropriate post-crash response . . . . .	133
4.8.1	Seat-belts and injuries . . . . .	135
4.8.2	Seat-belt removal . . . . .	135
	Summary . . . . .	138
	References . . . . .	140
<hr/>		
<b>5.</b>	<b>How to evaluate the programme . . . . .</b>	<b>143</b>
5.1	Planning the evaluation . . . . .	145
5.1.1	Aims of evaluation . . . . .	146
5.1.2	Types of evaluation . . . . .	147
5.2	Choosing the evaluation methods . . . . .	151
5.2.1	Study types for formative and process evaluations . . . . .	151
5.2.2	Study types for impact and outcome evaluations . . . . .	151
5.2.3	Choosing the performance indicators . . . . .	156
5.2.4	Conducting an economic evaluation of a programme . . . . .	157
5.2.5	Determining sample size . . . . .	158
5.3	Dissemination and feedback . . . . .	159
5.3.1	Checklist for evaluation process . . . . .	159
5.3.2	Using evaluation results to feed back into new planning cycle . . . . .	159
	Summary . . . . .	160
	References . . . . .	160



---

<b>Appendices</b> .....	163
Appendix 1. United Nations Economic Commission for Europe (UNECE) seat-belt questionnaire .....	165
Appendix 2. Sample seat-belt wearing observation form .....	174
Appendix 3. Example seat-belt wearing law .....	175
Appendix 4. Inspecting seat-belts and their components (from United Kingdom Vehicle Inspectorate inspection manual) .....	177
Appendix 5. Roadblock or checkpoint management .....	185
Appendix 6. Sample lesson plan for teaching seat-belt safety in secondary school .....	189
Partner organizations in the development of the manual .....	193
Glossary of terms .....	196
References .....	200



## Preface

Road traffic injuries are a major public health problem and a leading cause of death and injury around the world. Each year nearly 1.2 million people die and millions more are injured or disabled as a result of road crashes, mostly in low- and middle-income countries. As well as creating enormous social costs for individuals, families and communities, road traffic injuries place a heavy burden on health services and economies. The cost to countries, many of which already struggle with economic development, may be as much as 1–2% of their gross national product. As motorization increases, preventing road traffic crashes and the injuries they inflict will become an increasing social and economic challenge, particularly in developing countries. If present trends continue, road traffic injuries will increase dramatically in most parts of the world over the next two decades, with the greatest impact falling on the most vulnerable citizens.

Appropriate and targeted action is urgently needed. The *World report on road traffic injury prevention*, launched jointly in 2004 by the World Health Organization and the World Bank, identified improvements in road safety management and specific actions that have led to dramatic decreases in road traffic deaths and injuries in industrialized countries active in road safety. The use of seat-belts, helmets and child restraints, the report showed, has saved thousands of lives. The introduction of speed limits, the creation of safer infrastructure, the enforcement of limits on blood alcohol concentration while driving, and improvements in vehicle safety are all interventions that have been tested and repeatedly shown to be effective.

The international community must now take the lead to encourage good practice in road safety management and the implementation of the interventions identified in the previous paragraph in other countries, in ways that are culturally appropriate. To speed up such efforts, the United Nations General Assembly passed a resolution on 14 April 2004 urging that greater attention and resources be directed towards the global road safety crisis. Resolution 58/289 on “Improving global road safety” stressed the importance of international collaboration in the field of road safety. A further resolution (A/58/L.60), passed in October 2005, reaffirmed the United Nations’ commitment to this issue, encouraging Member States to implement the recommendations of the *World report on road traffic injury prevention* and commending collaborative road safety initiatives so far undertaken towards implementing resolution 58/289. In particular, it encouraged Member States to focus on addressing key risk factors and to establish lead agencies for road safety. In 2008, the United Nations passed a further resolution calling for a ministerial conference on global road safety.

To contribute to the implementation of these resolutions, the World Health Organization, the Global Road Safety Partnership, the FIA Foundation for the Automobile and Society, and the World Bank have collaborated to produce a series

of manuals aimed at policy-makers and practitioners. This manual on seat-belts and child restraints is one of them. Each provides step-by-step guidance to countries wishing to improve road safety organization and to implement the specific road safety interventions outlined in the *World report on road traffic injury prevention*. They propose simple, cost-effective solutions that can save many lives and reduce the shocking burden of road traffic crashes around the world. We encourage all to use these manuals.

**Etienne Krug**

Director

Department of Injuries and Violence Prevention

World Health Organization

**Andrew Pearce**

Chief Executive

Global Road Safety Partnership

**David Ward**

Director General

FIA Foundation for the Automobile and Society

**Anthony Bliss**

Lead Road Safety Specialist

Transport and Urban Development Department

World Bank

## Contributors and acknowledgements

### **Advisory Committee**

Anthony Bliss, Etienne Krug, Andrew Pearce, David Ward

### **Editorial Committee**

Kate McMahon, Andrew Downing, Kathleen Elsig, Andrew Pearce, Margie Peden, Tami Toroyan, Rita Cuypers

### **Contributors to modules and boxes**

Transport Research Laboratory, Kate McMahon, Cameron Black, Hung Dang Viet, T Bella Dinh-Zarr, Yvette Holder, Rebecca Ivers, Stephen Jan, Charles Mock, David A Sleet



## Executive summary

Increasing motorization worldwide has brought increases in crashes and injuries to vehicle occupants, particularly in low- and middle-income countries. One of the most effective measures to protect occupants from injury in the event of a crash is the fitment and use of seat-belts and child restraints. They are proven to save lives and reduce injury severity, and all vehicle occupants should be appropriately restrained when travelling in a motor vehicle. Seat-belts and child restraints are a secondary safety measure; though effective, they do not reduce crash risk, for which other primary safety measures are needed, particularly to protect vulnerable road users.

Worldwide, however, not all vehicles are fitted with seat-belts, and not all occupants use them when they are available. In countries where car use is rising most rapidly, the use of seat-belts and child restraints is low. More needs to be done to convince political leaders, police authorities, individual drivers and passengers that seat-belts provide essential protection from injury and can reduce the consequences of a crash. Comprehensive programmes of legislation, law enforcement, public education and publicity are needed to promote the benefits of seat-belt and child restraint use and to ensure compliance once legislation is in place.

The purpose of this manual is to provide advice and examples that will lead to increased use of seat-belts and child restraints as safety devices at a national level. The manual is aimed at policy-makers and road safety practitioners and draws on experience from countries that have succeeded in achieving and sustaining high levels of restraint use. It includes recommendations for developing and implementing technical standards and legislation, advice on how to monitor and evaluate progress, and suggestions regarding other multidisciplinary measures. A particular focus is the design and implementation of a programme to increase seat-belt wearing and child restraint use through legislation, enforcement and public education measures.

In developing the material for this manual, the writers have drawn on case studies from around the world to illustrate examples of “good practice”. Although specifically aimed at those countries with low seat-belt and child restraint use, it is hoped that the information and advice contained within this manual will also help countries with higher rates of use to further improve usage rates, reinforce their campaigns and direct further resources towards promotion of increased use.

Strategies that work in one country may not necessarily transfer effectively to another. The manual attempts to reflect a range of experiences from around the world, but does not offer prescriptive solutions. Rather, it is hoped that the manual can act as a catalyst for local initiatives and actions to improve road safety. It provides a base of information that stakeholders can use to generate their own solutions and develop advocacy tools and legislation to increase the use of seat-belts and child restraints that will work with the audiences they are trying to reach.

The checklist in Box 1 summarizes the steps needed to implement a programme to increase the use of seat-belts and child restraints.

### BOX 1: Key steps and programme activities

**1. Assess the current situation** using:

- casualty data;
- usage levels;
- consumer data;
- market data;
- situational data on legislation, penalties, standards and enforcement, publicity and education practices.

**2. Establish a working group** including all key stakeholders needed to develop and promote/advocate the action plan.

**3. Develop, manage and promote an action plan** that:

- is data led;
- is results focused, with objectives and targets;
- includes resource estimates;
- includes monitoring and evaluation for sustained improvement.

**4. Design and implement the action plan** using a combined multisectoral approach. Priorities should be chosen on the basis of the assessment and resources available. A combined enforcement and publicity campaign is recommended and the range of programme activities includes:

- improving legislation;
- increasing penalties;

- improving seat-belt equipment and fitting standards;
- strengthening inspection of standards and regulations;
- strengthening the enforcement strategy and training police as necessary;
- developing and delivering a targeted publicity campaign linked to and in advance of increased enforcement;
- facilitating other voluntary measures, such as employer education and regulation schemes, school, community and driver training programmes, and insurance incentive/deterrent schemes;
- improving post-crash responses, including first aid, rescue services and emergency medical care systems.

**5. Monitor and evaluate the programme.** There is a need to:

- begin the process at the start when planning the programme and collect data before implementing the plan;
- develop and test the methodology to meet objectives and measure change in target groups and related situations as frequently as necessary;
- collect the data and control quality carefully;
- disseminate the data widely and use results to improve the programme.





**Introduction**



## **Background to the series of manuals**

In 2004, for the first time ever, the World Health Organization (WHO) dedicated World Health Day to the topic of road safety. Events marking the day were held in over 130 countries to raise awareness about road traffic injuries, stimulate new road safety programmes and improve existing initiatives. On the same day, WHO and the World Bank jointly launched the *World report on road traffic injury prevention*, highlighting the increasing epidemic of road traffic injuries. The report discusses in detail the fundamental concepts of road traffic injury prevention, the impact of road traffic injuries, the main causes and risk factors for road traffic crashes, and proven and effective intervention strategies. It concludes with six important recommendations that countries can implement to improve their road safety record (Box 2).

### **BOX 2: Recommendations of the *World report on road traffic injury prevention***

1. Identify a lead agency in government to guide the national road traffic safety effort.
2. Assess the problem, policies, institutional settings and capacity relating to road traffic injury.
3. Prepare a national road safety strategy and plan of action.
4. Allocate financial and human resources to address the problem.
5. Implement specific actions to prevent road traffic crashes, minimize injuries and their consequences and evaluate the impact of these actions.
6. Support the development of national capacity and international cooperation.

The report stresses that the growing global problem can be averted with improved road safety organization and systemwide, multisectoral implementation of demonstrably effective interventions that are culturally appropriate and tested locally. In its fifth recommendation, the report makes it clear that there are several “good practice” interventions, already tried and tested, that can be implemented at low cost in most countries. These include strategies and measures that address some of the major risk factors for road traffic injuries, such as:

- setting laws requiring seat-belts and child restraints for all occupants of motor vehicles;
- requiring riders of motor cycles to wear helmets;
- establishing and enforcing blood alcohol concentration limits;
- setting and enforcing speed limits;
- managing existing physical road infrastructure in a way that increases safety;
- improving vehicle safety.

A week after World Health Day, on 14 April 2004, the United Nations General Assembly adopted a resolution calling for greater attention and resources to be directed towards road safety efforts. The resolution recognized that the United Nations system should support efforts to tackle the global road safety crisis. At the same time, it commended WHO and the World Bank for their initiative in launching the *World report on road traffic injury prevention*. It also invited WHO, working in close cooperation with the United Nations Regional Commissions, to act as coordinator on road safety issues within the United Nations system.

Following the mandate conferred on it by the United Nations General Assembly, since the end of 2004 WHO has helped develop a network of United Nations and other international road safety organizations, now referred to as the United Nations Road Safety Collaboration. The members of this group have agreed on common goals for their collective efforts, and are initially focusing attention on the six recommendations of the *World report on road traffic injury prevention*.

A direct outcome of this collaboration has been the setting up of an informal consortium consisting of WHO, the World Bank, the FIA Foundation for the Automobile and Society, and the Global Road Safety Partnership. This consortium is working to produce a series of “good practice” manuals covering the key issues identified in the *World report on road traffic injury prevention*. The project arose out of the numerous requests to WHO and the World Bank from road safety practitioners around the world for guidance in implementing the report’s recommendations.

The manuals are aimed at governments, nongovernmental organizations and road safety practitioners in the broadest sense. Written in an accessible manner, they provide practical steps on how to implement each recommendation in a way identified with good practice, while also making clear the roles and responsibilities of all those involved. The manuals are based on a common template that was used in a similar document on increasing seat-belt use, developed by the FIA Foundation in 2004. Although primarily intended for low- and middle-income countries, the manuals are applicable to a range of countries and are adaptable to different levels of road safety performance. Each manual includes case studies highlighting examples from both developed and developing countries.

The *World report on road traffic injury prevention* advocates a systems approach to road safety – one that addresses the road, the vehicle and the user. Its starting point is the belief that in order to effectively tackle road traffic injuries responsibility needs to be shared between governments, industry, nongovernmental organizations and international agencies. Furthermore, to be effective, road safety must have commitment and input from all the relevant sectors, including those of transport, health, education and law enforcement. These manuals reflect the views of the report; they too advocate a systems approach and – following the principle that road safety should be pursued across many disciplines – they are targeted at practitioners from a range of sectors.

## **Background to the seat-belt and child restraint manual**

### **Why was the seat-belt and child restraint manual developed?**

The seat-belt is the single most effective feature in a vehicle to reduce the severity of injury to the vehicle occupants that results from road traffic crashes. Article 7 of the Vienna Convention on Road Traffic of 1968 states: “The wearing of safety belts is compulsory for drivers and passengers of motor vehicles, occupying seats equipped with such belts, save where exceptions are granted by domestic legislation.”

This manual was developed in order to provide essential information on how to increase seat-belt and child restraint<sup>1</sup> usage rates at a national level. It is aimed primarily at low- and middle-income countries, and outlines the process for increasing wearing rates by examining the need for intervention, effective actions, laws and standards, programme implementation, and the impact of all multidisciplinary measures. It follows on from the *World report on road traffic injury prevention*, which described the evidence that legislating and enforcing mandatory use of seat-belts and child restraints is an effective intervention to reduce injuries and fatalities amongst vehicle occupants. It is one of a series of manuals that provide practical advice in an accessible form to countries on the steps necessary for improving their overall road safety record.

Seat-belts, of course, do not prevent a crash taking place. They do, however, play a crucial role in reducing the severity of injury to vehicle occupants involved in a crash.

### **Who is the manual for?**

The manual is intended to provide relevant information and give guidance to those countries that want to improve the use of seat-belts and child restraints, in particular those that do not, at present, have national legislation covering the fitment and wearing of seat-belts, and those that have poor wearing rates.

The manual targets all key stakeholders. These include:

- policy-makers
- members of the judiciary
- politicians
- police officers
- road safety and public health practitioners
- transport managers
- employers in the public and private sectors
- vehicle and component (including seat-belts and child restraints) manufacturers
- nongovernmental organizations

---

<sup>1</sup> Seat-belts and child restraints are sometimes collectively referred to as “occupant restraints”.

- insurance industry personnel
- school and college teachers
- researchers on road safety
- instructors in driving and road safety
- motoring and transport associations
- motor vehicle dealers.

Although aimed particularly at low- and middle-income countries with low levels of seat-belt and child restraint use, it is intended to be useful for all countries.

## **What does this manual cover and how should it be used?**

### **What is covered?**

Many countries and states have yet to address the possibility of reducing road death and injury through the use of seat-belts and child restraints. Some have only attempted to deal with the problem on a very basic level. For these countries, it is recommended that they systematically work through this manual to ensure a comprehensive approach that will increase vehicle occupant safety. The manual helps users to identify what actions are relevant to their situation, and provides the practical advice needed to implement the necessary steps. As well as focusing on technical issues, the manual also describes the institutional structures that need to be in place for a programme of measures to raise seat-belt and child restraint usage rates to be successful.

The manual covers both seat-belts and child restraints. In order to avoid duplication the main steps are discussed predominately with reference to seat-belts, but where necessary there is specific coverage of issues relevant to child restraint use.

The manual is divided into five modules, structured as follows:

- **Module 1** explains **why interventions to increase seat-belt and child restraint use are needed**. This module summarizes the evidence on effectiveness of seat-belts and child restraints in reducing injury, providing explanations of the benefits of use and how an increase in wearing rates can reduce the number of deaths and injuries taking place.
- **Module 2** provides guidance on **how to assess a country's situation regarding seat-belt and child restraint usage**. The module outlines the data needed for an accurate diagnosis of the problem and for identification of gaps and weaknesses in the mechanisms in place to address it.
- **Module 3** explains the need **to set up a working group** and how to use the assessment information **to prepare an action plan** including objectives, time frames and targets, prioritizing interventions and estimating resources to raise seat-belt and child restraint usage levels.

- **Module 4** is about **designing and implementing a seat-belt programme**. It recommends an approach combining legislation, penalties and standards with a range of interventions, including enforcement, education and publicity. It also gives guidance on appropriate rescue and medical responses for casualties of crashes.
- **Module 5** explains how to **evaluate a seat-belt programme**. It highlights the importance of building monitoring and evaluation into the project plan as an integral part of the campaign and identifies the data required.

### How should the manual be used?

The manual is not intended to be prescriptive, but rather adaptable to a particular country's current needs. The manual enables users to adopt a five-stage process (see Figure 1) for designing and implementing an effective seat-belt and child restraint

**Figure 1** General stages of a seat-belt and child restraint programme: from assessment to evaluation

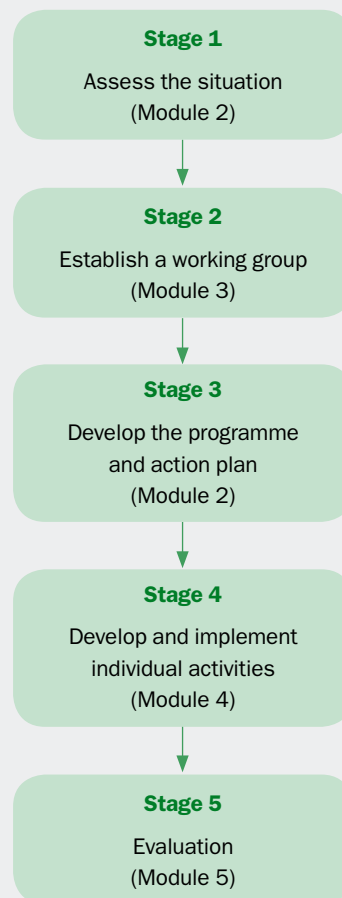

programme. Action plans (Stage 3) can be matched to countries' individual situations through the assessment process (Stage 1) and can be continuously adjusted and improved by monitoring and evaluation (Stage 5). The first part of Module 3 provides the crucial information on how to develop an action plan and select the appropriate interventions. The second part of Module 3 explains how to plan and implement each of these interventions effectively.

Readers are encouraged to read the entire manual; however, once interventions have been selected (see priority measures in Table 3.2 and checklist in Table 4.10), readers can study the appropriate sections on interventions in more detail to find out about recommended good practice and see some examples from other countries.

### **What are the limitations of this manual?**

This manual is not meant to be comprehensive. It draws upon the experience of its contributors to identify practical and effective steps that can be taken to save lives and reduce the injuries of vehicle occupants by increasing seat-belt and child restraint usage, and thus partly reflects the views of those involved in its production. There may well be successful interventions that are not reported here. Similarly, the case studies – used to illustrate processes, good practice and practical constraints – are not exhaustive but merely illustrate ideas presented in the main text.

The successes of all seat-belt and child restraint programmes are subject to the culture and environment of a country. Although the advice provided within this manual represents good practice, stakeholders should be aware that a programme that achieves success in one country may not be suitable for implementation in another country. Therefore an assessment should be made before implementation of any programme in order to determine its appropriateness for the target audience.

### **How was the manual developed?**

This manual has been produced after a full review of the FIA Foundation *Seat-belt campaign toolkit*, published in May 2004 (1). It is based on a standard template that was developed jointly by the four partner organizations (WHO, the World Bank, the FIA Foundation for the Automobile and Society, and the Global Road Safety Partnership), and reviewed externally. The template was not intended to be rigid, but to provide a loose structure that, where possible, would unify the manuals in their form and approach.

An advisory committee of experts from the different partner organizations oversaw the process of developing each manual, and provided guidance on its content. A small editorial committee for each manual then coordinated its technical content.

As part of the original research, a review of relevant literature was undertaken in order to gain as much knowledge as possible from any previous studies by international practitioners. Studies found and reviewed dated from 1969 to 2007.



Evaluations were also made of existing technical specifications, standards and regulations concerning the manufacture and installation of seat-belts.

Additional information was gathered through discussions with epidemiology, education, publicity and manufacturing experts. Clubs affiliated to the FIA Foundation also provided information relating to campaigns undertaken in their respective countries, and questionnaires were sent to the relevant government departments in 106 countries, covering legislation, penalties, campaigns, technical specifications and standards, and wearing rates. Information was also obtained from WHO highlighting those countries that had or had not implemented seat-belt wearing legislation.

Further literature, in hard copy and electronic formats, was sought. This was again compared with that used in the original toolkit to identify any examples of good practice for differing scenarios and environments. Partners were consulted in order to obtain case studies that were as diverse as possible, geographically and in terms of income level.

Technical experts were consulted in order to provide additional information that would reinforce the detail of the manual and allow decision-makers to make an informed choice about how to implement, manage and monitor campaigns relating to manufacturers, users and the industry as a whole. Information was obtained from medical, technical, manufacturing, policing, education and publicity experts.

The draft manual was then put through a process of peer review.

### **Dissemination of the manual**

The manual is being translated into a number of languages, and countries are encouraged to translate the document into local languages. The manual will be disseminated widely through the distribution network used for the *World report on road traffic injury prevention*. The four partner organizations involved in the manual will plan training workshops to accompany in-country launches of the manual.

The manual will also be available in PDF, downloadable free from the web sites of each of the four partner organizations.

### **How to get more copies**

Further copies of the manual can be ordered by writing to:

FIA Foundation  
60 Trafalgar Square  
London WC2N 5DS  
United Kingdom

Or by e-mailing: [mail@fiafoundation.org](mailto:mail@fiafoundation.org)

## **Reference**

1. *Seat belt campaign toolkit*. London, FIA Foundation, May 2004 (<http://www.fiafoundation.org/news/archive/2004/Pages/Seatbeltcampaigntoolkit.aspx>, accessed 20 October 2008).

# 1

**The need for seat-belts  
and child restraints**

<b>1.1 Road traffic death and injury as a worldwide public health problem</b> .....	3
1.1.1 Worldwide trends in road traffic death and injury .....	3
1.1.2 Types of injuries sustained by vehicle occupants .....	5
<b>1.2 How seat-belts and child restraints prevent or minimize injury</b> .....	6
1.2.1 What happens in a crash? .....	6
1.2.2 How a seat-belt works .....	7
1.2.3 How a child restraint works .....	7
<b>1.3 Recommended types of seat-belts and child restraints</b> .....	8
1.3.1 Seat-belt design .....	8
1.3.2 Types of child restraints .....	9
<b>1.4 Effectiveness of seat-belt and child restraint use in preventing death and reducing injury</b> .....	12
1.4.1 Effectiveness of seat-belts .....	12
1.4.2 Effectiveness of child restraints .....	15
1.4.3 Seat-belt wearing rates .....	16
1.4.4 Child restraint use rates .....	19
<b>1.5 Effectiveness of seat-belt and child restraint programmes at increasing wearing rates by vehicle occupants</b> .....	19
<b>Summary</b> .....	22
<b>References</b> .....	23

**T**HIS MODULE provides the user with background material on why seat-belts and child restraints are needed. Such information is important in persuading political leaders and the public to support seat-belt programmes and policies and in increasing overall restraint use by drivers and passengers around the world.

The sections in this module are structured as follows:

**1.1 Road traffic death and injury as a worldwide public health problem.** The module begins by describing the magnitude of the problem of motor vehicle crashes, and the resulting injuries that are sustained by occupants. It explains the global distribution of the problem, noting that if present trends continue, many low- and middle-income countries are likely to experience an increase in the number of crashes in the near future as the level of motorization increases.

**1.2 How seat-belts and child restraints prevent or minimize injury.** This section describes how seat-belts and child restraints protect vehicle occupants and reduce the impact of a collision.

**1.3 Recommended types of seat-belts and child restraints.** The various types of seat-belts and restraints are described in this section.

**1.4 Effectiveness of seat-belt and child restraint use in preventing death and reducing injury.** This section presents evidence from studies that have evaluated the effectiveness of seat-belts and child restraints in reducing death and injury.

**1.5 Effectiveness of seat-belt and child restraint programmes at increasing wearing rates by vehicle occupants.** This section shows how legislation on compulsory seat-belt use coupled with supportive programmes and enforcement have been effective in increasing wearing rates.

## **1.1 Road traffic death and injury as a worldwide public health problem**

---

### **1.1.1 Worldwide trends in road traffic death and injury**

Road traffic injuries are a major public health problem and a leading cause of death and injury around the world. Approximately 1.2 million people are killed each year in road crashes worldwide, with up to 50 million more injured. Over 95% of these deaths and injuries occur in the low- and middle-income countries of Africa, Asia, Latin America, the Caribbean and Eastern Europe (1).

Although the global trends in road traffic fatalities over the past 20–30 years have shown an overall increase, the situation varies considerably between different regions of the world. In the high-income countries of North America, Western Europe and

Japan, road deaths fell by approximately 20% between 1980 and 2000. In contrast, over the same period road deaths increased in low- and middle-income countries by between 50% and 100%. Data suggest that these trends will continue and that by 2020 road traffic deaths will increase by 83% in low- and middle-income countries, and decrease by 27% in high-income countries. These figures amount to a predicted global increase of 67% by 2020 (1).

The extent to which different road users are affected by road traffic injuries also differs between countries. The distribution of those killed in various modes of transport in different countries is shown in Figure 1.1. Of those killed on the roads in high-income countries, the majority are drivers and passengers in cars (2). The data in Figure 1.1 show that vehicle occupants account for as much as 80% of all road traffic deaths in the United States of America, but only 10–20% in countries in South-East Asia, where two-wheeler motorized traffic predominates. However, although in low- and middle-income countries car occupants do not comprise the majority of fatalities on the road, experience from high-income countries suggests that as car ownership rises so too will the number of vehicle occupant deaths and injuries. Experience from rapidly motorizing nations to date concurs with these trends: for example, in 2003 more than 12 000 new cars were registered every day in China, while in Viet Nam official sources report that 600 new cars are being registered every day (3). The use of seat-belts and child restraints could prevent many of these deaths and serious injuries that occur among four-wheeled vehicle occupants.

**Figure 1.1 Road users killed in various modes of transport as a proportion of all road traffic deaths**

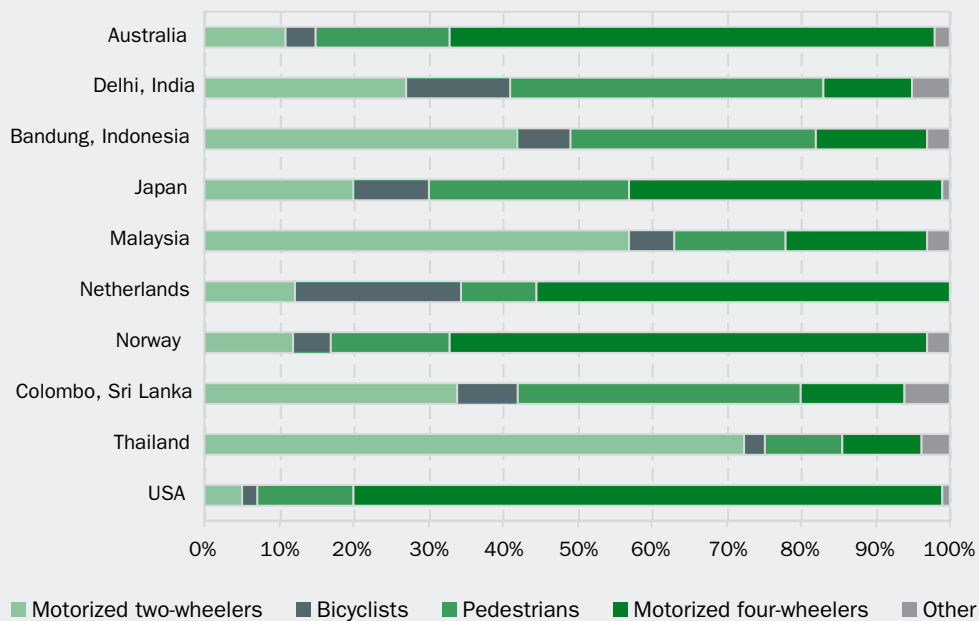

Adapted from reference 1

### 1.1.2 Types of injuries sustained by vehicle occupants

There are three “collisions” that occur in every crash where occupants are unrestrained. The **first collision** involves the vehicle and another object, e.g. another vehicle(s), a stationary object (tree, signpost, ditch) or a human or animal. The **second collision** occurs between the unbelted occupant and the vehicle interior, e.g. the driver hits his chest on the steering wheel or his head on the window. Finally, the **third collision** occurs when the internal organs of the body hit against the chest wall or the skeletal structure. It is the second collision that is most responsible for injuries, and can be reduced significantly by the use of seat-belts and child restraints.

The most frequent and most serious injuries occurring in frontal impacts to occupants unrestrained by seat-belts are to the head, followed in importance by the chest and then the abdomen. Among disabling injuries, those to the leg and neck occur most frequently (4, 5).



#### Norway study of head injuries

A study in Norway calculated that head injuries make up some 60% of all injuries to vehicle occupants. The study concluded that drivers and front seat passengers who do not use seat-belts suffer almost the same percentage of head injuries as non-users in rear seats (6).

Failure to use a seat-belt is a major risk factor for road traffic deaths and injuries among vehicle occupants. Passengers who were not wearing their seat-belts at the time of a collision account for the majority of occupant road traffic fatalities. In addition, passengers who do not wear seat-belts and have a frontal crash are most likely to suffer a head injury.

Although of paramount concern, there is more than just the human suffering associated with non-use of seat-belts. The financial burden of increased death and injury severity can have a major impact on the finances of the government and local communities who are paying for the resources that are required to deal with road crash victims and their families in the aftermath of a crash.

## 1.2 How seat-belts and child restraints prevent or minimize injury

This section describes what happens during a motor vehicle crash and how seat-belts and child restraints prevent or reduce the severity of injuries sustained.

### 1.2.1 What happens in a crash?

When a crash occurs, a car occupant without a seat-belt will continue to move at the same speed at which the vehicle was travelling before the collision and will be catapulted forward into the structure of the vehicle – most likely into the steering wheel if they are driving, or into the back of the front seats if they are rear seat passengers. Alternatively, they can be ejected from the vehicle completely. Being ejected from a vehicle drastically increases the probability of sustaining severe serious personal injury or being killed (7).



#### Seat-belts as a protection against ejection

The American College of Emergency Physicians advocates the use of seat-belts as the best protection against ejection in a crash. Ejection from a vehicle is one of the most injurious events that can happen to a person in a crash, with 75% of all vehicle occupants ejected from a vehicle in a crash dying as a result. Seat-belts are effective in preventing ejections: overall, 44% of unrestrained passenger vehicle occupants killed are ejected, partially or totally, from the vehicle, as compared to only 5% of restrained occupants (8, 9).

The use of seat-belts and child restraints is one of the most important actions that can be taken to prevent injury in a motor vehicle crash. While seat-belts and child restraints do not prevent crashes from taking place, they play a major role in reducing the severity of injury to vehicle occupants involved in a collision. An occupant's chance of survival increases dramatically when appropriately restrained.



### 1.2.2 How a seat-belt works

Seat-belts and child restraints are **secondary** safety devices and are primarily designed to prevent or minimize injury to a vehicle occupant when a crash has occurred. Seat-belts and child restraints thus:

- reduce the risk of contact with the interior of the vehicle or reduce the severity of injuries if this occurs;
- distribute the forces of a crash over the strongest parts of the human body;
- prevent the occupant from being ejected from the vehicle in an impact;
- prevent injury to other occupants (for example in a frontal crash, unbelted rear-seated passengers can be catapulted forward and hit other occupants).



A belted occupant will be kept in their seat and thus will reduce speed at the same rate as the car, so that the mechanical energy to which the body is exposed will be greatly reduced.

### 1.2.3 How a child restraint works



(Richard Stanley/FIA Foundation)

Infants and children need a child restraint system that accommodates their size and weight, and can adapt to cope with the different stages of their development.

The three-point lap and diagonal seat-belt used by adults is not designed for children's varying sizes, weights, and the different relative proportions of children's bodies. For example, a smaller portion of a child's abdomen is

covered by the pelvis and rib cage, while a child's ribs are more likely than an adult's to bend rather than break, resulting in energy from a collision being transferred to the heart and lungs (10). Consequently three-point lap and diagonal seat-belts may lead to abdominal injuries among children, and will not be optimally effective at preventing ejection and injury among them.

Appropriate child restraint systems are specifically designed to protect infants and young children from injury during a collision or a sudden stop by restraining their movement away from the vehicle structure and distributing the forces of a crash over the strongest parts of the body, with minimum damage to the soft tissues. Child restraints are also effective in reducing injuries that can occur during non-crash events, such as a sudden stop, a swerving evasive manoeuvre or a door opening during vehicle movement (11).

## **1.3 Recommended types of seat-belts and child restraints**

### **1.3.1 Seat-belt design**

This section describes the main elements of seat-belt design. Seat-belt designs should comply with national or international standards (covered in Module 3 of the manual). Designs that ensure ease of use will serve to increase wearing rates.

The three-point lap and diagonal seat-belt is the safest and most commonly used in cars, vans, minibuses, trucks and the driver's seat of buses and coaches, while the two-point lap belt is most commonly used in buses and coaches. Seat-belt standards set out requirements for the width of webbing and buckles, and the ease of operation and adjustment. In more recent years seat-belts have become integrated into overall vehicle safety systems that include such devices as pretensioners, load limiters and airbags.

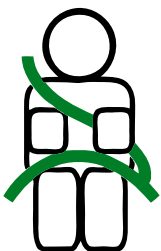

#### **Three-point lap and diagonal seat-belt**

Rated highly for effectiveness and ease of use, the three-point lap and diagonal seat-belt is the most commonly used in cars, vans, minibuses and trucks and in the driver's seat of buses and coaches. The seat-belt tongue clips into the buckle, which in the front seats of cars is usually placed on the end of a stiff stalk or directly attached to the seat. A retractor device is included as part of the belt system as this ensures unnecessary slack is taken up automatically. This system allows the occupant to connect the tongue and buckle using one hand, preventing ejection after maintaining the seating position of the occupant.

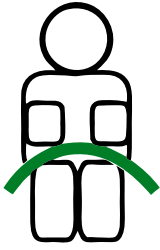

### Two-point lap belt

A two-point lap belt (sometimes called a “single lap belt”) using a retractor device is inferior to the three-point lap and diagonal seat-belt described above but can be sufficient to maintain the seating position of the occupant, particularly in coaches or buses.

Crash studies have shown that although the lap belt does fulfil the task of reducing ejection, it fails to prevent the occupant’s head and upper body moving forward and hitting the vehicle interior. For the driver, this could result in serious head injuries from contact with the steering wheel. However, because of the size and mass of coaches, the severity of injury when involved in a collision with another vehicle is often minor compared to that other vehicle if it is a car or van.



### Single diagonal belt

The single diagonal design does provide better restraint for the upper body of the wearer than the two-point lap belt, but has been shown to be poorer at preventing ejection and submarining (slipping under the seat-belt).

### Full harness

The full harness (double shoulder, lap and thigh straps with central buckle device) gives very good protection both from ejection and from interior contact. However, it is somewhat cumbersome to put on, and cannot be easily operated with one hand. This is an important factor in achieving a high wearing rate, and thus the harness only tends to be installed in vehicles used for motor sport, where drivers and co-drivers are at high risk.

## 1.3.2 Types of child restraints

The safest place for children aged 12 years and under is in the back seat, properly restrained in an approved child safety seat. Specially manufactured child restraints should be used for children. There are a number of different types of restraints. The main determining factor for choice of a child restraint is the child’s weight (Table 1.1). Older children who are above the height and weight specifications for using child restraints require a properly fitting three-point lap and diagonal seat-belt when riding in a vehicle.

**Table 1.1** Weight categories of child restraints

Group	Description
0	For children of a mass less than 10 kg
0+	For children of a mass less than 13 kg
I	For children of a mass from 9 kg to 18 kg
II	For children of a mass from 15 kg to 25 kg
III	For children of a mass from 22 kg to 36 kg

### Infants under the age of 1 year (Group 0 or 0+)



At birth, the infant head is around a quarter of their total length and about a third of their body weight. An infant's skull is very flexible, so a relatively small impact can result in significant deformation of the skull and brain. The smaller the child, the less force needed for injury. The infant rib cage is also very flexible. Impact can result in a large compression of the chest wall onto the heart and other abdominal organs. The infant pelvis is unstable and cannot be secured by an adult restraint system. Infants require their own special seats for them in a crash, and provide protection from many types of impacts. Some seats are convertible; that is, they can revert to a full child safety seat when the child is older.

A rear-facing child restraint system (sometimes called an “infant car seat”) provides the best protection for infants until they are both 1 year of age and at least 13 kilograms (kg) weight. For the best protection, infants should be kept rear facing for as long as possible. The safest place for infants is in the back seat in an approved rear-facing infant car seat.

### Children aged 1–4 years (Group I)



The bone-forming process is not complete until the age of 6 or 7 years, and throughout childhood a child's skull remains less strong than that of an adult. A restraint system needs to limit forward head movement in a frontal impact and provide protection from intrusion in a side impact. A child restraint should therefore distribute the crash forces over as wide an area as possible. Belts and harnesses need to fit well and be properly positioned as designed by the manufacturer. The restraint system should also provide protection from contact with the vehicle interior in both front and side impacts.

The best type of child restraint for young children is the child safety seat. The integral harness secures the child and spreads the crash forces over a wide area. This seat will last them until either their weight exceeds 18 kg or they grow too tall for the height of the adjustable harness.

### Children aged 4–6 years (Group II)



They are best used only when a child has outgrown a safety seat. They are suitable for children with weights from 15 kg to 25 kg. Children should continue to ride in a child safety seat until the lap and diagonal belts in the car fit properly, typically when the child is approximately 145 centimetres (cm) tall (12). Booster seats raise the seating child so that the adult seat-belt lies properly across the chest, crossing over the child's shoulder rather than the neck, and low across the pelvis. If the seat-belt is too high across the stomach, in a crash serious internal injury could occur as the child could submarine under the seat-belt. The booster seat has a backrest that provides some protection in a side impact.

### 6–11 years (Group III)

Booster cushions without backs are designed for weights from 22 kg to 36 kg, but manufacturers are now producing booster cushions with backs that cover the full 15 kg to 36 kg range. Shield booster seats, which have a plastic shield in front of the child, offer less protection and should not be used. Booster seats for children aged 4–7 years have been shown to reduce injury risk by 59% compared to seat-belts alone (13).

Recent research suggests that children whose restraints are placed in the centre rear seating position incur less injuries than those placed on the outer seats, although this is in contrast to some earlier research that found that the centre seat was not a



safe option (14, 15). It should also be noted that although children are best secured in age-appropriate child restraints, if such restraints are not available, it is still better to use an adult seat-belt on the child than leave the child unsecured on the back seat (16, 17).

### Child restraint systems

Currently, most child restraint systems are designed to be installed using the vehicle's seat-belt. ISOFIX is a system that uses purpose-designed mounting points provided in the vehicle to attach the child restraint with a rigid mechanism, rather than using the seat-belt to secure the restraint (18). ISOFIX is increasingly used in Australia and in Europe, and similar systems have been adopted in the United States (LATCH) and in Canada (UAS).

## 1.4 Effectiveness of seat-belt and child restraint use in preventing death and reducing injury

### 1.4.1 Effectiveness of seat-belts

Since the 1960s studies conducted throughout the world have shown conclusively that seat-belts save lives, when worn and fitted correctly. A review of research on the effectiveness of seat-belts found that their use reduces the probability of being killed by 40–50% for drivers and front seat passengers and by about 25% for passengers in rear seats (Table 1.2) (7). The impact on serious injuries is almost as great, while the effect on slight injuries is smaller at 20–30%. More detailed analyses indicate that seat-belts are most effective in frontal impacts and in run-off-the-road crashes, where the probability of being ejected is high if seat-belts are not worn (19).

**Table 1.2** Effect of seat-belts on the probability of personal injury in all types of collisions (individual effects)

Injury severity	Percentage change in number of injuries	
	Best estimate	95% confidence interval
<i>Drivers of light vehicles (private cars and vans)</i>		
Killed	–50	(–55; –45)
Serious injuries	–45	(–50; –40)
Minor injuries	–25	(–30; –20)
All personal injuries	–28	(–33; –23)
<i>Front seat passengers in light vehicles (private cars and vans)</i>		
Killed	–45	(–55; –25)
Serious injuries	–45	(–60; –30)
Minor injuries	–20	(–25; –15)
All personal injuries	–23	(–29; –17)
<i>Back seat passengers in light vehicles (private cars)</i>		
Killed	–25	(–35; –15)
Serious injuries	–25	(–40; –10)
Minor injuries	–20	(–35; –5)
All personal injuries	–21	(–36; –6)

Source: Adapted from Table 4.12.1 in reference 7.

The actions of rear seat passengers can affect both injuries that they themselves might incur and those that may be sustained by the driver or front seat passenger. An unrestrained rear seat passenger poses a serious threat to any restrained person seated directly ahead of them (20). Thus the use of seat-belts by rear seat passengers could not only reduce the likelihood and severity of injury to themselves, but also to drivers and front seat passengers.

**NOTE****Seat-belts and crash fatality rates**

Seat-belts are approximately 50% effective in preventing fatalities in crashes in which motorists would otherwise die. It is estimated that seat-belt use prevented about 15 200 deaths in the United States in 2004. If all passenger vehicle occupants over 4 years of age in the United States had used seat-belts in 2004, nearly 21 000 lives could have been saved (that is, an additional 5800 lives) (21).

**NOTE****Cost savings through seat-belt use**

Between 1975 and 2000, the United States saved US\$ 588 billion in casualty costs due to seat-belt use. The annual savings have increased significantly as seat-belt wearing has increased among vehicle occupants. For example, the annual economic saving due to seat-belt use in 1975 was US\$ 1.5 million. By 2000, that figure had risen to US\$ 49.9 million. However, road death and injury from non-use of seat-belts still costs American society an estimated US\$ 26 billion annually in medical care, lost productivity and other injury-related costs (8).

### BOX 1.1: Airbags, seat-belts and child restraints

Airbags are a supplemental restraint system, designed to add additional protection to seat-belts in (primarily) frontal crashes over 13 kilometres per hour (km/h). While airbags have saved many lives, there have also been deaths attributed to airbags deploying in crashes that would not have been life threatening.

Analysis of deaths involving airbags in the United States showed that nearly all of the people who have died from airbag-related injuries were either unrestrained or improperly restrained (22). Most of the deaths have been to children and adults of small stature. Airbags are a passive restraint system, deploying automatically in some types of crashes. If an occupant is unrestrained, or the vehicle has an airbag installed but no seat-belt, it is possible that the occupant may come into contact with the airbag before it has fully inflated. This is also the case for people who need to sit closer to the steering wheel as a result of their size. Airbags deploy at approximately 300 km/h. Therefore, vehicle occupants should ensure that they are restrained



[www.euroncap.com](http://www.euroncap.com)

regardless of whether or not a vehicle has an airbag installed.

Manufacturers should be aware of the potentially dangerous implications of installing an airbag without also fitting a seat-belt, and parents should never position a child in an infant or child safety seat in front of an airbag. Some vehicles have been equipped with an airbag on/off switch requiring the driver to vigilantly monitor the airbag status to

ensure maximum protection for passengers. More recently, manufacturers have designed “second-generation” or “smart” airbags that use sensors to detect when and at what speed to deploy, based on crash configurations and occupant characteristics. The safest way to ensure that children under 12 years of age are not injured by an airbag is to restrain them in a rear seat. Drivers

should sit at least 25 cm from the steering wheel, and be properly restrained to minimize contact with the airbag if it deploys. The airbag must be reinstalled following each airbag deployment.

### BOX 1.2: The trauma care cost of not wearing a seat-belt

Data from the North Carolina Trauma Registry were analysed to determine the effect of seat-belt usage on outcome in motor vehicle accidents. Of 6237 persons involved in motor vehicle accidents, data on seat-belt usage were available for 3396. Of these, 1480 were wearing seat-belts and 1916 were not. Comparison of hospital charges and outcomes for the belted and unbelted patients showed that seat-belts could have saved at least 74 lives and US\$ 7.2

million. There were 135 deaths among the unbelted patients (7.0%) and 47 deaths among the belted patients (3.2%). Head injury was more common and more severe in unbelted drivers. This is important because head injury is a major factor in mortality. Seat-belt usage is associated with a significant decrease in mortality rate, hospital charges, length of stay, intensive care unit stay and ventilator requirements (23).



### 1.4.2 Effectiveness of child restraints

Like adult seat-belts, child restraints in cars are intended to keep a child firmly secured in their seat so that in the event of sudden braking or collision the child is not thrown against the car interior or ejected from the vehicle. The restraint must absorb kinetic energy (created by the motion of the child during the crash) without itself injuring the child and must be easy to use.

A review of the effectiveness of child restraints compared the risk of injury to children in different seating positions in cars (7). Children who sit in the rear without child restraints have around 25% lower risk of being injured than children who sit in the front without restraints. For children using restraints in both seating positions the risk in the rear is 15% lower than in the front (Table 1.3).

**Table 1.3** Effects of child restraints in cars on child's risk of injury as a passenger

Type of restraint used	Percentage change in risk of injury	
	Best estimate	95% confidence interval
Restraining children aged 0–4 years in a forward-facing child restraint	–50	(–70; –30)
Restraining children aged 0–4 years in a rear-facing child restraint	–80	(–90; –70)
Restraining children aged 0–4 years with a seat-belt only	–32	(–35; –29)
Restraining children aged 5–9 years in appropriate child restraint with seat-belt	–52	(–69; –27)
Restraining children aged 5–9 years using seat-belt only	–19	(–29; –7)

Source: Adapted from Table 4.13.2 in reference 7.

The effect of child restraints varies depending on the type of restraint used. A child up to 4 years of age has a 50% lower risk of injury in a forward-facing child restraint and 80% lower in a rear-facing seat. This compares with injury reduction of only 32% when an adult seat-belt is worn (7).

For children aged 5–9 years, child restraints reduce injury by 52%, whereas for seat-belts alone the reduction is only 19%. For older children aged 10–14 years seat-belts reduce injury by 46%.

**NOTE****Promoting booster seat use**

A systematic review of interventions to promote booster seat use by children aged 4–8 years showed that combining financial incentives or distribution of free booster seats with education demonstrated marked beneficial outcomes for acquisition and use (24).

A review of various United States studies has shown that child safety seats that are correctly installed and used for children aged 0–4 years can reduce the need for hospitalization by 69% (25). The risk of death for infants is reduced by 70%, and that for children aged 1–4 years by 47–54%. Of children aged under 5 years, 485 lives could have been saved in the United States in 2002 if all the children had been in child safety seats (26).

It has been estimated in the United Kingdom that new rules on the use of child restraints rather than adult seat-belts for children up to 135 cm in height or aged 12 years and above will save over 2000 child injuries or deaths every year (27).

**1.4.3 Seat-belt wearing rates**

Rates of seat-belt use vary greatly between countries, governed to a large extent by the type of laws that require seat-belts to be fitted in vehicles and cars, and the laws requiring them to be worn. Rates are also dependent on the degree to which these laws are enforced (see Figure 1.2). In many low-income countries there is no requirement for belts to be fitted or used, and rates of use are therefore correspondingly low. In addition there may be cultural norms that negatively influence seat-belt wearing rates, particularly among young adult car occupants.

**NOTE****Age and seat-belt use**

Compared with older drivers, young drivers and front-seat passengers are less likely than older drivers and passengers to use seat-belts while in a moving vehicle (28).

**Figure 1.2** Use of seat-belts by car drivers/front-seat passengers in urban and non-urban areas of Finland, 1966–1995

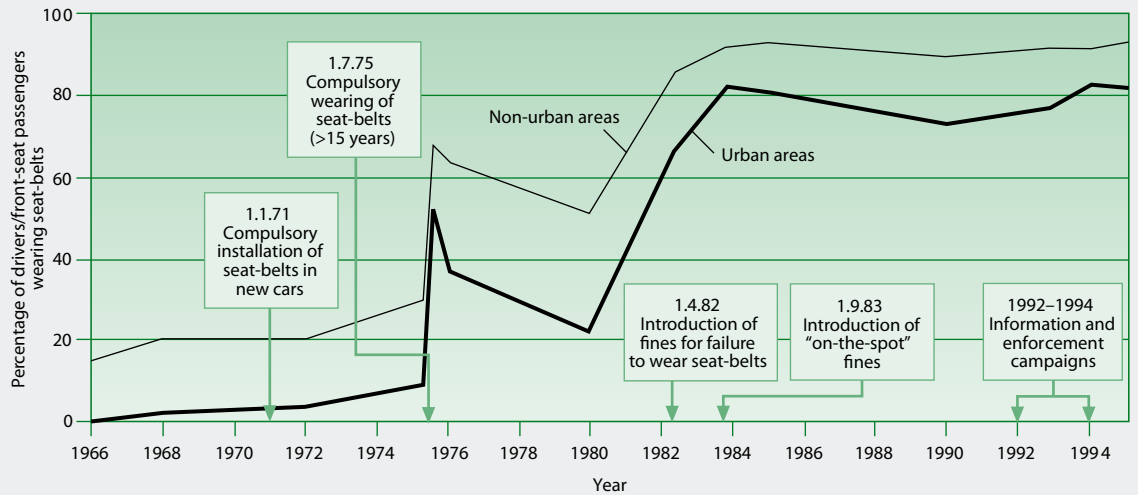

Table 1.4 shows the wearing rates for selected countries. There is considerable variation in wearing rates, despite legislation on mandatory use in all countries, and rates are generally lower in rear seats than in front seats. For many of these countries there is potential for improvement in wearing rates.

**Table 1.4** Seat-belt wearing rates for selected countries

Country	Front seat driver %	Front seat passenger %	Rear seat %
Albania	52	27	27
Bulgaria	55	55	n/a
Canada	91	90	80
Costa Rica	82	76	48
Croatia	65	27	8
Czech Republic	61	n/a	13
Denmark	84	n/a	58
Egypt	70	45	n/a
Estonia	73	75	21
Finland	89	89	80
France	88	97	n/a
Germany	93	95	86
Israel	91	88	34
Luxembourg	74	78	60
Malta	99	93	25
Mauritius	94	84	n/a
Netherlands	90	91	69
Norway	85	90	92
Portugal	88	84	25
Slovenia	83	83	40
South Africa	81	50	8
Spain	87	89	52
Switzerland	81	n/a	56
United Kingdom	93	93	83

n/a = not available

Source: UNECE questionnaire and various other published articles (2004).

**NOTE****Fatalities and seat-belt use in European Union**

Analysis by the European Transport Safety Council estimates that within the European Union seat-belts currently reduce driver fatalities by 40%. Wearing rates in European countries vary widely from around 70% to over 95%. If all European Union countries were to achieve a 99% wearing rate for drivers, 2400 lives would be saved each year (29).

#### 1.4.4 Child restraint use rates

In many high-income countries the use of child restraints is common – with usage rates up to 90% – but in other countries they are still rarely used. Choosing and installing the appropriate child restraint system is important. Even in countries where the use of child restraints is high, such as Sweden, the United Kingdom and the United States, restraints are frequently inappropriately used or misused. For instance, a child may be restrained in the wrong system for its age or weight, or the straps or harnesses may not be adequately secured or entirely left undone, thus placing the child at an increased risk of both fatal and non-fatal injuries (25).

Appropriate child restraint use may be limited by access and cost, or simply be impractical because of a large family size. In addition, a number of decisions about what seat to choose, where to place it and how to install it need to be made by parents. A lack of awareness about the benefits of appropriate and correctly used restraints can jeopardize their effectiveness. For instance, a study in Greece found that the majority of parents (88.4%) positioned their children on the back seat unrestrained, while 76.1% of those that did put their child into a restraint did not do this consistently (30).

### 1.5 Effectiveness of seat-belt and child restraint programmes at increasing wearing rates by vehicle occupants

---

The technical effectiveness of seat-belts and child restraints is well researched and proven. Properly designed and fitted restraints save lives. Once seat-belts have been installed in a vehicle, the next objective is to ensure that the vehicle occupants use them. There are a number of ways that this can be achieved. Laws making seat-belt use compulsory are essential in increasing the wearing of seat-belts in all countries, especially in low- and middle-income countries, where seat-belt wearing rates are low. To ensure that a much higher level of seat-belt wearing is achieved, a comprehensive programme is required (Box 1.3). To be successful, legislation should be preceded by public information campaigns to raise awareness of the benefits of wearing seat-belts and to provide information on the requirements of the law. Strong enforcement, especially in the period immediately after the law is implemented, and continuing publicity and enforcement campaigns are also required, both before enactment and during the initial enforcement period. Although legislation is essential, it will not achieve high wearing rates unless it is part of a comprehensive programme of legislation, enforcement, publicity, incentives and encouragement.

**BOX 1.3: Strategies to bring about increased seat-belt wearing rates**

**Seat-belt legislation and enforcement.** Introducing and enforcing a mandatory seat-belt law is needed if rates of seat-belt wearing are to be increased and maintained. This usually requires laws ensuring that all passenger vehicles are fitted with appropriate seat-belts, as well as laws requiring that they are worn. In the United States, for example, one of the strongest predictors of seat-belt use among young drivers is a state's seat-belt law. Between 2000 and 2004, rates of seat-belt use were higher and fatality rates lower, in every age group, in all states that enforced a seat-belt law compared to those that did not (31).

**Ensuring that vehicles are fitted with appropriate seat-belts.** Although rules that require all cars to

be fitted with seat-belts are now in place in most countries, there is evidence that half or more of all vehicles in low-income countries may lack properly functioning seat-belts (32).

**Seat-belt public awareness campaigns.** Laws mandating seat-belt use should be backed up by public education campaigns. Such campaigns may focus on young people, and can be used both to increase awareness and to help make wearing seat-belts a social norm.

**Community-based projects.** Community projects can employ parents and peers to encourage young people to wear seat-belts.

It is important to note that most studies that examine the impact of seat-belt laws have been conducted in high-income countries, where legislation when introduced is heavily enforced, and is usually preceded by extensive publicity campaigns. Although it seems very likely that the introduction of seat-belt wearing legislation in low- or middle-income countries will decrease fatality rates among motor vehicle occupants, there are several unknown factors. Availability of suitable seat-belts and child restraints is variable across such countries, and the likely level of enforcement is also a factor that must be considered. Legislation is most likely to work where seat-belts are widely fitted as standard, where enforcement is comprehensive and where there is widespread community education on the benefits of seat-belt use. In low- and middle-income countries where police resources are constrained and community attitudes to seat-belt wearing are not supportive of legislation, effective enforcement requires widespread government support.

**Enforcement of seat-belt law in Argentina**

In Argentina a seat-belt law was introduced in Buenos Aires in 1992 that raised wearing rates for drivers from 6% to 32% but, due to lack of enforcement, rates subsequently declined to 13% by 1995. New laws and campaigns raised the rate to 22% by 2004, but the major gain was made through an enforcement effort that raised the rate to 77% by February 2005. If that wearing rate could be achieved and maintained across Argentina, 1000 lives could be saved each year (33).

Programmes that have introduced manufacturing or wearing legislation and delivered a sustained enforcement effort, while using publicity and education to raise awareness and increase compliance, have proven to be successful in raising wearing rates. Table 1.5 highlights the achievements of selected countries.

**Table 1.5** Increases in front seat-belt wearing rates in selected countries after the implementation of legislation and campaigns

Country	Wearing rates (%) prior to legislation and campaigns	Wearing rates (%) after legislation and campaigns
Australia	25	95*
Austria	30	70
Costa Rica	24	82
Croatia	50	80
Czech Republic	30	60
Denmark	5	94
Finland	40	93
India	0.5	50*
Japan	37	84
Netherlands	15	86
Norway	10	94
South Africa	33	81*
Spain	25	86
Sweden	20	90
United Kingdom	25	91

\* Differs between states.

Mandatory child restraint laws and their enforcement also lead to an increase in the use of child restraints and have been shown to be effective at reducing deaths and injuries among children (25). As with seat-belt programmes, successfully increasing child restraint use requires appropriate legislation and enforcement, as well as community-wide information campaigns. As child restraints are not installed within vehicles like seat-belts but must be purchased and fitted by parents it is more challenging to achieve high usage rates, especially in low- and middle-income countries. Module 3 provides more detail on measures to increase child restraint use.

**BOX 1.4: International support for seat-belt wearing**

International recommendations provide strong support for countries to implement programmes that legislate for mandatory seat-belt use. Some countries may use the international policy environment and international law as a means of providing the necessary impetus for developing national policies on seat-belt use. International agreements can also be used by civil societies to advocate seat-belt law reform in their own countries.

The *World report on road traffic injury prevention* recommends that all countries, regardless of their level of income, follow several good practices, including “setting and enforcing laws requiring seat-belts and child restraints for all motor vehicle occupants” (1).

In 2004, the World Health Assembly (WHA) adopted resolution WHA57.10, which recommends Member States, “especially developing countries, to make mandatory both provision of seat-belts by automobile manufacturers and wearing of seat-belts by drivers” (34).

The WHA resolution is an international agreement that can be used by those wishing to influence policy on seat-belt use as a basis for obtaining political support for this measure. In particular, such a resolution has direct relevance for ministries of health, who, by adopting WHA resolutions, undertake to support the principles enshrined in them.

United Nations General Assembly resolution A/60/5 (2005) “Invites Member States to implement the recommendations of the *World report on road traffic injury prevention* including those related to the five main risk factors, namely the non-use of safety belts and child restraints, the non-use of helmets, drinking and driving, inappropriate and excessive speed, as well as the lack of appropriate infrastructure” (35).

United Nations General Assembly resolution A/62/L.43 (2008) repeated the 2005 resolution call for implementation of the *World report on road traffic injury prevention* recommendations.

**Summary**

The seat-belt is an effective safety tool that not only saves lives, but also significantly reduces the severity of injury that a vehicle occupant may have sustained if they were not wearing the device. Around half of all deaths of front seat occupants could be prevented through the correct use of seat-belts.

Motor vehicle users make up a high proportion of overall traffic injuries and deaths in high-income countries, and in low- and middle-income countries the proportion is growing as motor vehicle ownership is increasing. It is therefore vital that seat-belt use is increased in these countries to prevent a rapid growth in death and injury among vehicle occupants.

Children should use restraints that are suitable for their size. Use of the appropriate type of restraint for a child’s age, height, weight and physical limitations reduces deaths of children by between 50% and 75%.

Programmes that set and enforce mandatory seat-belt legislation, combined with public education campaigns, are effective at increasing seat-belt wearing rates and thus reducing injuries and fatalities. Seat-belt laws that are implemented through primary enforcement are more effective in increasing wearing rates than laws implemented through secondary enforcement.

There is strong international support for seat-belt wearing programmes.



## References

1. Peden M et al., eds. *World report on road traffic injury prevention*. Geneva, World Health Organization, 2004.
2. *International road traffic and accident database*. Organisation for Economic Co-operation and Development (<http://cemt.org/IRTAD/>, accessed 5 November 2008).
3. *Turning the tide: injuries and violence prevention in China*. Beijing, China, World Health Organization, 2006 (<http://www.wpro.who.int/NR/ronlyres/05F04193-96CB-4A11-873A-A99CACBB45D3/0/injurychina.pdf>, accessed 5 November 2008).
4. Mackay M. The use of seat-belts: some behavioural considerations. *Proceedings of the risk-taking behaviour and traffic safety symposium, 19-22 October 1997*. Washington, DC, National Highway Traffic Safety Administration, 1997:1-14.
5. Hobbs CA, ed. *Priorities for motor vehicle safety design*. Brussels, European Transport Safety Council, 2001.
6. *Restraints for adults and children in the back seat of private cars: an estimation of the effect of alternative regulations*. Report 37A. Nordisk Trafiksikkerhedsrad, 1984.
7. Elvik R, Vaa T, eds. *The handbook of road safety measures*. Elsevier, 2004.
8. *Seat-belts*. Texas, United States, American College of Emergency Physicians (ACEP), 2002 (<http://www.acep.org/patients.aspx?LinkIdentifier=id&id=26106&fid=1348&Mo=No&acepTitle=Seat%20Belt%20Fact%20Sheet>, accessed 5 November 2008).
9. *The critical need for active ongoing seat-belt use programs in rural areas*. National Highway Traffic Safety Administration, 2006 (<http://www.nhtsa.dot.gov/people/injury/airbags/RuralCrashes/pages/CriticalNeed.htm>, accessed 5 November 2008).
10. Tingvall C. Children in cars: some aspects of the safety of children as car passengers in road traffic accidents. *Acta Paediatrica Scandinavica*, 1987, Suppl. 339:1-35.
11. Agran PF, Dunkle DE, Winn DG. Motor vehicle childhood injuries caused by noncrash falls and ejections. *Journal of the American Medical Association*, 1985, 253:2530-2533.
12. *Child passenger safety program*. United States Department of Transportation, National Highway Traffic Safety Administration (NHTSA) (<http://www.nhtsa.gov/portal/site/nhtsa/menuitem.9f8c7d6359e0e9bbb30811060008a0c/>, accessed 5 November 2008).
13. Durbin DR, Elliott MR, Winston FK. Belt-positioning booster seats and reduction in risk of injury among children in vehicle crashes. *Journal of the American Medical Association*, 2003, 289(14):2835-2840.
14. Kallan MJ, Durbin DR, Arbogast KB. Seating patterns and corresponding risk of injury among 0- to 3-year-old children in child safety seats. *Pediatrics*, 2008, 121(5):e1342-e1347.
15. Lund UJ. The effect of seating location on the injury of properly restrained children in child safety seats. *Accident Analysis and Prevention*, 2005, 37(3):435-439.
16. Hertz E. *Revised estimates of child restraint effectiveness*. Research Note. Washington DC, National Highway Traffic Safety Administration, 1996.
17. Johnston C, Rivara FP, Soderberg R. Children in car crashes: analysis of data for injury and use of restraints. *Pediatrics*, 1994;6:960-965.
18. *ISOFIX and passenger safety systems in road vehicles*. International Organization for Standardization ([http://www.iso.org/iso/support/faqs/faqs\\_widely\\_used\\_standards/widely\\_used\\_standards\\_other/isofix\\_and\\_passenger\\_safety\\_systems\\_in\\_road\\_vehicles.htm](http://www.iso.org/iso/support/faqs/faqs_widely_used_standards/widely_used_standards_other/isofix_and_passenger_safety_systems_in_road_vehicles.htm), accessed 5 November 2008).

19. Evans L. Safety belt effectiveness: the influence of crash severity and selective recruitment. *Accident Analysis and Prevention*, 1996, 28:423–433.
20. Broughton J. *The threat posed by unrestrained rear seat car passengers*. TRL Report 563. Crowthorne, United Kingdom, TRL Ltd, 2003.
21. *The national initiative for increasing safety belt use: Buckle Up America campaign*. Eighth Report to Congress. National Highway Traffic Safety Administration, 2005 (<http://www.nhtsa.dot.gov/people/injury/airbags/8thBUARReport/index.htm>, accessed 5 November 2008).
22. *Air bags*. Texas, United States, American College of Emergency Physicians (ACEP), 2002 (<http://www.acep.org/practres.aspx?LinkIdentifier=id&id=26100&fid=1348&Mo=No&acepTitle=Air%20Bag%20Safety>, accessed 5 November 2008).
23. Rutledge R et al. The cost of not wearing seat-belts. *Annals of Surgery*, 1993, 217(2):122–127.
24. Ehiri JE et al. *Interventions for promoting booster seat use in four to eight year olds traveling in motor vehicles*. Cochrane Database of Systematic Reviews, Issue 4, 2007.
25. Zaza S, Sleet DA, Thompson R. Review of evidence regarding interventions to increase the use of child safety seats. *American Journal of Preventive Medicine*, 2001, 21(Suppl. 4):31–34.
26. *Traffic safety facts 2002: occupant protection*. DOT HS 809 610. National Highway Traffic Safety Administration, 2003 (<http://www-nrd.nhtsa.dot.gov/pdf/nrd-30/NCSA/TSF2002/2002occfacts.pdf>, accessed 5 November 2008).
27. *Amendment to the seat-belt wearing regulations*. United Kingdom Department for Transport, 2006 (<http://www.dft.gov.uk/consultations/about/ria/amendmenttotheseatbeltwearingin5501?page=2#a1024>, accessed 5 November 2008).
28. Williams AF et al. Seat belt use of high school drivers and their passengers. *Journal of Traffic Medicine*, 1997, 25:21–25.
29. *Road safety performance Index Flash 4: increasing seat-belt use*. European Transport Safety Council, 2007 (<http://www.etsc.be/documents/PIN%20Flash%204.pdf>, accessed 5 November 2008).
30. Tsoumakas K et al. Parents knowledge and attitudes about preventing injuries in motor vehicle accidents in children in Greece. *Traffic Injury Prevention*, 2008, 9(2):129–134.
31. Liu C et al. *States with primary enforcement laws have lower fatality rates*. Traffic Safety Facts Research Note, DOT HS 810 557. Washington, DC, National Highway Traffic Safety Administration, 2006.
32. Forjuoh S. Traffic-related injury prevention interventions for low-income countries. *Injury Control and Safety Promotion*, 2003, 10:109–118.
33. Silveira AJ. *Seat-belt use in Buenos Aires, Argentina: a 14-year-old struggle*. Luchemos por la Vida. Paper presented at the International Conference on Traffic Safety on Four Continents, Warsaw, October 2005.
34. *Road safety and health*. Resolution WHA57.10 of the World Health Assembly, 57th session, 22 May 2004 ([http://www.who.int/violence\\_injury\\_prevention/publications/road\\_traffic/en/index.html](http://www.who.int/violence_injury_prevention/publications/road_traffic/en/index.html), accessed 5 November 2008).
35. *Improving global road safety*. Resolution A/60/5 of the United Nations General Assembly, 60th session, 1 December 2005 ([http://www.who.int/violence\\_injury\\_prevention/publications/road\\_traffic/en/index.html](http://www.who.int/violence_injury_prevention/publications/road_traffic/en/index.html), accessed 5 November 2008).

# 2

**How to assess the situation  
in a particular country**

<b>2.1 The need to assess the current situation</b> .....	27
2.1.1 Understanding the current situation through baseline data collection .....	27
2.1.2 Quality of the data .....	29
<b>2.2 How to assess the extent of the problem of non-use of seat-belts and child restraints</b> .....	29
2.2.1 Assessing the extent of the vehicle occupant injury problem .....	30
2.2.2 What are the seat-belt and child restraint wearing rates in the area being considered? .....	35
2.2.3 Why do people not wear seat-belts and use child restraints? .....	40
<b>2.3 How to assess what is already in place</b> .....	46
2.3.1 Who is in charge of road safety, and what funds are there for it? . . .	46
2.3.2 Who are the stakeholders? .....	48
2.3.3 Is there a seat-belt use law in place? .....	49
2.3.4 Is there a seat-belt and child restraint standard in place? .....	51
2.3.5 Have any seat-belt and child restraint programmes been attempted so far? .....	51
2.3.6 Using the situational assessment to prioritize actions .....	53
<b>Summary</b> .....	53
<b>References</b> .....	54

**MODULE 1** explained why seat-belts and child restraints are needed to reduce the fatalities and injuries that are associated with motor vehicle crashes. Before designing and implementing a strong seat-belt and child restraint programme, it is important to assess the situation and needs in the community, region or country where the programme will be implemented. This is often called a “needs assessment”. Many of the steps in this process will also be necessary to monitor the seat-belt programme, once it is in place.

The sections in this module are structured as follows:

**2.1 The need to assess the current situation.** A situational or needs assessment to determine the extent of the problem is the basis for creating an effective seat-belt and child restraint programme. In addition, needs assessments are essential for galvanizing support and obtaining funding for programmes (and are often required in funding applications).

**2.2 How to assess the extent of the problem of non-use of seat-belts and child restraints.** This section provides guidance on how to:

- assess the extent of the vehicle occupant injury problem;
- measure seat-belt and child restraint usage;
- determine the reasons for lack of seat-belt and child restraint use.

**2.3 How to assess what is already in place.** This section describes the questions that need to be asked in order to collect information on what national processes are under way in the country or region with regard to seat-belt and child restraint use. To do this, it is necessary to find out who is responsible for road safety, and consider all those who may have an interest in a seat-belt and child restraint programme. The module gives guidance on how to collect comprehensive information on the institutional and legislative structures that are in place that might have an impact on the programme, and how to find out about any existing or previous seat-belt and child restraint programmes in the project area, in order to learn from these experiences and to identify the potential resources (financial, personnel and institutional) for future programmes.

## **2.1 The need to assess the current situation**

### **2.1.1 Understanding the current situation through baseline data collection**

Those planning a seat-belt or child restraint programme may already have an understanding of some of the information and issues around restraint use in their

country or region, and thus may feel they do not need to conduct a situational or needs assessment. Nonetheless, conducting a well-planned and thorough situational assessment is strongly advised prior to starting any new programme. This does not necessarily imply a prolonged and complicated process, but can mean simply taking the time to search for and compile all the existing relevant information. The most important information to collect is data on current use of seat-belts and child restraints. In addition, although the causal link between restraint use and injury reduction is generally well known, evidence on injury rates for belted and unbelted occupants if available is useful to support the case for legislation on mandatory use. A situational or needs assessment is essential to obtaining initial and continued support and funding for any programme. It will show the gravity of the problem in the specified location and, once the programme is implemented, the initial results can be compared to later evaluations (see Module 5) in order to demonstrate the effectiveness of the programme.

There are three main reasons for assessing the situation before starting a seat-belt and child restraint programme.

- To identify **the problem of lack of restraint use** and to depict **the scale of the problem**. Ideally, the information gathered will illustrate injury and fatality rates amongst belted and unbelted people; differences in wearing rates according to age, sex and location; where the greatest need for increasing wearing rates is; the cost of not using seat-belts; and the reasons why vehicle occupants do not use seat-belts. This in turn helps set priorities for action.
- To provide **evidence** for arguments on why restraint use is essential and why it should be supported. A seat-belt and child restraint programme, in order to be successful, needs the backing of both policy-makers and the public. Accurate data – on factors such as seat-belt and child restraint use and injuries among belted and unbelted occupants in the project area – will help to show what can be gained by implementing a programme, and provide arguments to convince policy-makers and the general public of the need for a comprehensive programme. Module 1 provided background data on the evidence for the effectiveness of restraints in reducing deaths and injuries that can also be used in support of setting up a local programme.
- To provide **baseline indicators** that can be used for monitoring and evaluating a programme. This may include quantitative information such as seat-belt wearing rates, as well as qualitative information such as public opinion on seat-belt use, or information on compliance with legislation.

These data provide stakeholders with a clear understanding of the current situation in relation to seat-belt and child restraint use, legislation, manufacturing standards and the capacity for change. They also provide useful baseline figures against which the effectiveness of future actions can be evaluated.

Determining the mechanisms currently in place to increase seat-belt and child restraint usage can help stakeholders identify any shortfalls in legislation or

implemented campaigns. For example, it may reveal that no enforcement of existing legislation is undertaken.

### 2.1.2 Quality of the data

Good data are important in assessing the situation. This means data that are appropriate, accurate, complete and reliable. In collecting data, one can also identify problems in the data system itself. For example, in collecting data on seat-belt and child restraint use in a region, it may become clear that the data on seat-belt wearing rates are incomplete. Knowledge of such shortcomings in the data can help set realistic objectives as part of the programme.

Nonetheless, in many countries where reporting systems are not well established or coordinated, some of the necessary data will not be available. Lack of data should not be used as an excuse for inaction or ignoring a country's problem of crash injuries. Some country-level data are always available, no matter how rudimentary these may be, and they can be used as a starting point to develop a strategy for increasing seat-belt use.

Methods for collecting data will vary and the data obtained will probably also depend on the source. Hospital data on crashes and injuries incurred, for instance, may be biased because they only take into account cases that are actually brought to the hospital. Similarly, police data on crashes will only record those cases the police investigate. However, either of these two sources is a good starting point.

Data collection should ideally be led by a person who has experience in epidemiology. Module 3 discusses the establishment of a working group to develop a seat-belt and child restraint programme. The public health expert in the working group is probably the most suited person to take charge of this task.

## 2.2 How to assess the extent of the problem of non-use of seat-belts and child restraints

---

The next two sections guide users on how to gather the information needed for assessing the situation. Collecting such detailed data on some of these issues will be an essential part of any seat-belt use intervention, both as a component of the programme itself and for the purpose of monitoring and evaluation.

### 2.2.1 Assessing the extent of the vehicle occupant injury problem

This assessment involves examining data on road traffic crashes in order to gauge the extent of the problem with regards to vehicle occupants, and collecting information on injuries among motor vehicle users.

#### Collecting data on road traffic crashes

Developing appropriate measures to address a road safety problem requires accurate data on the extent of the problem of road traffic crashes, and in particular on motor vehicle crashes and the injuries that result. The data should be used to highlight specific dangers facing motor vehicle occupants, and to emphasize the need for an action programme.

Information will be needed on the incidence, severity and types of crashes. A thorough understanding of the causes of crashes is also important. Information such as locations with an increased risk for motorists, or groups of drivers at increased risk, will be valuable for targeting the programme. For instance, it may turn out that busy urban roads or rural roads are the highest risk areas; young males may be the group found to be at special risk, or people driving as part of their work.

To collect these data, the following questions need to be asked:

- How many injuries and deaths are there as a result of road traffic crashes in the project region? Note that it is important for the working group to predefine the unit of assessment (see Module 3). For example, this may be the entire country, or it may be a particular province or state, or town or community.
- What is the scale of the problem of crashes involving motor vehicle occupants, in terms of the number of crashes and the number of fatalities, distinguishing between belted and unbelted occupants?
- How does this problem compare, in terms of its scale and the burden on society, with other local public health problems?
- Who are those most likely to be unrestrained in crashes?
- What proportion of vehicles have seat-belts fitted? In the front? In the back?
- What are the wearing rates of seat-belts and child restraints in the front and in the back of vehicles?

The indicators to be used here include:

- injury data showing severity and mortality rates amongst belted and unbelted occupants;
- the age and sex of drivers and passengers involved in crashes;
- wearing rates by sex, age and seating position;
- the distribution of crashes across different road types;
- the age and sex of drivers and passengers involved in these crashes;
- proportion of vehicles by type with fitted seat-belts, distinguishing between front and rear.



Data from surveys and interviews on public attitudes and opinions are useful in determining reasons for non-use in order to develop effective interventions.

### Locating the required information

Some countries have national data collection systems on road traffic deaths, injuries and disabilities. Traffic police may collect some of this information, but generally such data collection results from collaboration between the police and the transport and health departments. Although traffic crash data systems usually lack detail on the injuries sustained, asking the questions may help to either find where this information is available, or at least show that particular data are lacking. If this is not available, use can be made of other specific data sources, which are listed below.

**Police authorities.** In most jurisdictions investigating crashes is the responsibility of the police. Crash data by severity should be collected in order to provide baseline data for injury rates prior to a seat-belt campaign. Where reporting rates for injury data are suspect, fatality data alone will provide good evidence on the effectiveness of seat-belt campaigns. Police records may also provide information on whether seat-belts were in use in crashes, though these data are not always reliable. Such data will probably also be handled by the country's traffic safety agency or transportation department, so that information from these bodies should also be considered "official data".

In practice, full information on these factors is rarely available, as data may not be complete. Issues of underreporting in police records exist even in those countries with a good road safety record.

**Hospital data.** In some countries, the health system is the only comprehensive source of data about road crash injuries. Hospital records are likely to include mainly the most seriously injured casualties, but they are a useful source of information on the distribution of injury types. Since motor vehicle injuries are admitted through the emergency or trauma department it might be efficient to begin the search for data using emergency department records and charts. It is useful to make periodic studies of hospital data, either from a single hospital or a group of hospitals in an area. By extrapolating a sample of data, an order of magnitude estimate can be obtained of the scale of the problem nationally or provincially. These studies should extract information on:

- the type of injury, for instance the body region injured;
- the nature of the motor vehicle crash;
- the types of injuries that most frequently result in death;
- information on those involved in crashes, such as sex, age and occupation.

**Death certificates.** Another source of data is death certificates or coroner reports, although the information and quantity is limited as the numbers will not include non-fatal injuries. Usually, any physician (not just the coroner) can sign a death

certificate, but most jurisdictions keep all death certificates in one government-run location, such as the ministry of health.

**Health clinics.** Some localities do not have trauma centres or hospitals nearby, and rely on local health clinics or primary care treatment facilities to treat injuries and illnesses. These may be suitable sites for collecting basic information on the nature and circumstances of a motor vehicle crash, injuries sustained and seat-belt use.

**Employers.** Often, larger employers collect and retain data on crashes and injuries to their drivers, especially in occupational driving settings. Looking at employer data can give a picture of how risky occupational driving can be, and the benefits (both economic and worker-related) of a mandatory seat-belt use policy for occupational drivers.

**Insurance companies.** Insurers, both health and automobile, may be a convenient source of data. Looking at insurance claims data can yield important insights into costs of care related to motor vehicle crashes, and the benefits of wearing seat-belts to reduce health-care claims.

**In-depth crash injury studies.** Although police and hospital data will provide information on injury trends, detailed comparison of the extent and severity of injury in belted occupants compared with unbelted occupants may only be available from in-depth research. Other sources of data of this kind might be nongovernmental organizations, universities, research organizations and insurance companies.

**Similar or neighbouring countries.** Although no two countries or regions will be identical in the circumstances and conditions with regard to vehicle crashes, where data from a country are lacking, it can be helpful to examine what data are available from similar or neighbouring countries. Such data can be used in support of a seat-belt programme in the country of interest, provided that a clear statement is made that it has been assumed that the two countries are similar with respect to certain factors.



### CASE STUDY: **Data collection through crash injury study, United Kingdom**

The United Kingdom's Co-operative Crash Injury Study (CCIS) is one of Europe's largest car occupant injury causation studies. Multidisciplinary teams examine crashed vehicles and correlate their findings with the injuries the victims suffered to determine how car occupants are injured. The investigation teams monitor details of all the injury car crashes within their geographical areas. All fatal and serious injury crashes and a random sample of slight injury crashes are selected. Each year a total of 1176 vehicles are examined. Details of the occupants' injuries are encoded into the Abbreviated Injury Scale

(AIS) format to allow for database analysis across thousands of crashes. Questionnaires are sent to occupants and provide very useful supplementary information. The vehicle information and occupant injury details are correlated to determine, where possible, the causes of injury. This information is compiled into a complete crash record that can be used by researchers.

The CCIS database has been used to estimate seat-belt effectiveness and the additional effects of airbags (1).

#### **Collecting data on injuries**

The protection provided by seat-belts increases with crash severity. The effect is most marked for prevention of fatalities, but also for the most serious injuries. Seat-belts reduce the incidence of ejection from vehicles, and the injuries due to striking the windscreen. The CCIS database shows that 83% of unbelted occupants who died when their cars rolled over had been ejected, compared with 25% of belted occupants (2).

Understanding the effects of a seat-belt programme will include the need to collect data on injury severity and, if available, injury type. The latter will be helpful in providing information on how the range of injuries (by severity) has changed, as well as the number of injuries. However, the high effectiveness of seat-belts means that even in the absence of detailed injury records, overall numbers of casualties can be a reasonable measure of the benefits. A note of caution is necessary where traffic levels are increasing rapidly, as any subsequent increase in crashes may distort the measure of the estimate of the effect of seat-belt wearing.

To collect these data, the following questions need to be asked:

- What proportion of motor vehicle crashes involve fatal injuries? What is the distribution of injury by body region, by injury score or by severity, as defined by the police? Some injury scores used by medical professionals include the Abbreviated Injury Scale (AIS), Maximum Abbreviated Injury Scale (MAIS), Injury Severity Score (ISS) and Probability of Death Score (PODS).
- What are the economic and social impacts of these crashes and injuries on the country's resources?
- What is the geographical distribution of motor vehicle occupant injuries within the region?

- Are there particular population groups in the region that are at increased risk of injuries resulting from motor vehicle crashes, for instance men, women, young people, ethnic minorities or a particular occupation?
- What other information is collected on those injured as a result of motor vehicle crashes? For example, are those injured generally the drivers or passengers, and do they usually own the vehicle?
- Is there information on seat-belt and child restraint use among motor vehicle crash victims? If available, this will allow a comparison of outcome of crashes involving motorists with and without restraints.

Table 2.1 indicates some of the more commonly used sources of data on injuries, and gives other potential sources of data on injuries.

**Table 2.1 Possible sources of data on injuries, according to severity of injury**

	No injury	Mild	Moderate	Severe	Fatal
Household (community) surveys					
Health clinic records					
Family doctors' records					
Emergency room records					
Ward admission records					
Intensive care unit admission records					
Death certificates					

**Other potential sources of data on fatal and severe injuries are:**

- For fatal injuries:
- autopsy/pathology reports
  - police reports.
- For severe non-fatal injuries:
- hospital inpatient records
  - trauma registries
  - ambulance or emergency medical technician records.

**Additional sources of data on specific types of injury are:**

- For motor vehicle injuries:
- automobile insurance company records
  - police traffic accident reports
  - department of transport reports.
- For occupational injuries:
- workplace records
  - labour inspector or national safety records
  - national insurance schemes/workers' compensation bureau
  - rehabilitation centres.

Source: This information is extracted from the *Injury surveillance guidelines* (3).

### **2.2.2 What are the seat-belt and child restraint wearing rates in the area being considered?**

An accurate assessment of the current situation with regard to seat-belt fitment (the number of vehicles fitted with seat-belts for all seating positions) and overall seat-belt and child restraint use will provide any country or state with a number of baseline figures that future programmes will aim to improve. Therefore, all subsequent assessments become indicators of success. In relation to a programme designed to increase seat-belt usage, it is vitally important to determine current wearing rates and to examine existing mechanisms in place that promote the use of the safety device.

Assessing the proportion of motor vehicle users wearing seat-belts will be an important factor to consider in arguing for a seat-belt programme. This means asking the following questions:

- What is the proportion of seat-belt use among vehicle occupants nationally (or in the project area)? This rate (percentage of belted occupants by seating position) should also be used as a baseline indicator against which to evaluate the programme's effectiveness.
- What types of people are not wearing seat-belts? Can a breakdown be arrived at in terms of age, sex, whether the person is a driver or passenger and purpose of the journey?
- What is the cost of the non-use of seat-belts, in terms of injuries sustained by motor vehicle users involved in crashes?

#### **Where will these data come from?**

Data on seat-belt use may be available from the following sources:

- police records
- records of national or local health authorities
- national transportation agency records
- research studies and surveys.



### CASE STUDY: **Seat-belt use in Malaysia**

Road traffic injuries are a major public health problem in Malaysia. They constitute the second leading cause of burden of mortality. Vehicle occupants constituted about 18% of road fatalities in 2003. Legislation for seat-belt use in the front seats was introduced in 1978. The usage of seat-belts in both front and rear seats was studied using similar methodology in the same urban and rural districts in 1995 and 2006.

Factors affecting seat-belt use included age, sex, ethnic group and location of road. There was an increase in the usage of seat-belts as age increased up to the age of 69 and a slight decline after the age of 70 among the front seat occupants. There was a low use of seat-belts among adolescents, with only 50% of adolescent drivers and 76.5% of adolescent passengers in the front seat using seat-belts compared with the overall rates of 84% (rural) and 87%

(urban). A higher percentage of female drivers (91%) wore seat-belts than male drivers (82%). If the driver was belted, there was a higher probability that the front seat passenger was belted. Usage of child restraints was minimal, and rear seat-belt wearing was also very low, 10% on urban roads and 3% on rural roads.

Over the 10-year period seat-belt use has shown a slight increase on urban roads, and a larger increase, from a lower rate, on rural roads, so that the urban/rural difference has narrowed. Though the law was introduced nearly 30 years ago, it needs to be enforced. Usage of child restraints should be promoted. A significant number of deaths and unnecessary disability can be prevented through the improvement of seat-belt use (4, 5).

### **Observational surveys of seat-belt use**

If accurate current information on the extent of seat-belt wearing is lacking it will be necessary to carry out observational surveys. These may be concentrated in particular regions or at particular locations. Since an increase in the usage of seat-belts will be a key objective of any campaign, it will be important to establish a reliable regime for measuring and monitoring seat-belt use on a regular basis. This does not have to be a nationwide survey, but it should ideally cover a range of road types and locations.

Sites should be selected such that all road types are represented so that as far as possible correlation may be made between urban and rural roads, motorways and unclassified roads, built-up areas and non-built-up areas, and so on. Sites should be assessed for the ease with which they allow the survey staff to observe and record the use of seat-belts and child restraints by vehicle occupants. For example, sites where traffic lights are installed allow survey staff time to view vehicle occupants clearly. This helps to ensure that results can be generalized to represent different vehicles and different journeys. This need to observe the car occupants is a limiting factor in carrying out surveys on high-speed roads such as motorways.

The sites selected for observation can depend to some extent on the survey staff. Compromises can be made on the data being nationally representative to ensure quality of data over quantity of data. Therefore, it is better to accept surveys conducted in one or two smaller locations where the researcher can rely on quality of data than try to blanket large parts of the country or state and receive inaccurate data

from unreliable survey staff. To ensure consistency in data, researchers should try to use the same sites for every subsequent observation. The case studies below from Ghana and the United Kingdom give examples of procedures that have been used.



### CASE STUDY: **Assessment of seat-belt wearing rates, Ghana**

The first national study on seat-belt compliance in Ghana took place in 2006 as part of the Drive to Live Programme. Seat-belt usage was measured in a series of observations undertaken in the country's regions with the highest crash rates. The study (sample size 12 000) also recorded motorcycle helmet usage, mobile phone usage and spectacle wearing. The data were collected prior to a road safety campaign that encouraged seat-belt wearing and switching off phones while driving. A set of "after" campaign data will be collected, which will also be used to inform a national seat-belt campaign.

Observations were made at the point of sale for fuel (fuel stations). The surveys were conducted between 07:00 and 09:00, and between 16:00 and 18:00, corresponding to the peak periods for retail sales, and included collection of both weekday and weekend data.

Survey supervisors were chosen from subcontractors regularly used by a company specializing in surveys. The supervisors trained regional enumerators to conduct the surveys at the fuel stations. Two enumerators were assigned to each fuel station (with the exception of two sites where four were used) to record the following information:

- seat-belt usage (driver and passenger)
- usage by five vehicle classes
- motorcycle helmet usage
- use of mobile phone while driving
- spectacle wearing.

These observations indicated about 40% compliance overall with seat-belt usage laws, with the highest rates amongst car drivers (up to 50%) and the lowest rates amongst truck drivers (less than 20%) (6).



### CASE STUDY: **Seat-belt wearing survey procedures, United Kingdom**

In the United Kingdom, surveys of seat-belt use have been carried out every year since October 1988 in April and October, when journeys are less likely to be affected by summer holidays and adverse weather. Initially only two areas, Crowthorne and Nottingham, were surveyed, but in 1998 the coverage was extended and by 2002 further summer surveys in 10 additional areas were carried out. Teams of three observers are used and observations are made between 08:30 and 17:30 in eight half-hour sessions. All observations are made in daylight to ensure visibility of seat-belt use.

Two team members observe the occupants of passing vehicles, including their age, sex and seat-belt use. Their observations are recorded using a hand-held computer, with one electronic form being completed for each car that is surveyed. The third team member counts the number of vehicles passing during each session.

In order to be able to look into cars to record the seat-belt use of rear seat passengers, only stationary cars are observed, so survey sites are located

wherever possible at junctions with automatic traffic signals. When the traffic stops at the approach to the junction, the pair of observers proceeds along the queue of vehicles, observing the occupants of each stationary vehicle in turn. When the queue starts to move, they return to the junction and wait for the traffic to stop once more before restarting the process.

A clear sampling strategy is required. For example, at a traffic signal location:

1. When the signal turns red, observe the first car that stops.
2. As time permits, observe in strict order any stationary vehicles queuing behind the first.
3. When the lights change, suspend observation until the next red period.

The survey sites are chosen so as to be representative of all types of road and traffic. However, the need to observe stationary vehicles means that it is impossible to make observations on motorways, and there are few suitable sites on rural roads (7).

Box 2.1 describes how to set up an observational study. A sample seat-belt wearing observation form is given in Appendix 2.



### BOX 2.1: Measuring seat-belt wearing rates: an observational study

Even if detailed and comprehensive data are lacking, it should be possible to conduct a simple observational study to obtain a good estimate of seat-belt use. Simple counts of drivers and passengers using seat-belts, at particular locations and at different times of the day, will provide a rough estimate of how many motorists are using seat-belts and will later be of use in developing actions to be taken.

Because of cost, this type of study is often done on a small scale. If it is already known that a high proportion of crashes and injuries occur on particular roads or in particular areas, it is recommended that the study be carried out in those high-risk locations.

This observation method for calculating seat-belt wearing rates in a population could be used for data collection in situational assessment, as well as in an experimental or quasi-experimental evaluation design (see Module 5).

#### Planning period

Before conducting an observational survey, the target population should be clearly defined in terms of who they are, where they live and over what period of time data will be collected. Detailed road maps and data on traffic volume and estimated population prevalence of seat-belt use from other sources should be collected for the area of interest.

#### Develop a data collection protocol

This is a detailed written document describing the approach that will be used to collect data. It includes what will be done, how it will be done, who will do it and when it will be done.

#### Develop data collection instruments

These include a form or set of forms used to collect information (e.g. questionnaires, interview schedules). Training material should also be developed for staff carrying out roadside observations.

#### Sampling

The observed population should be representative of the population of interest in the target area. This means that a random sample of the population should be observed. Although non-random samples may be more feasible in certain situations, for example observations made at fuel stations or

outside schools, consideration should be given to how generalizable or representative the results from such selective samples would be.

If the aim of the study is to document seat-belt wearing in a particular geographical area, then all road types should be included in the design of the study. Seat-belt wearing may differ across different road types; for example, drivers may be more likely to wear seat-belts on highways than on local roads. The sampling frame should therefore be designed such that it ensures adequate counts to enable an estimate of seat-belt use across different road types, and also ensures a mix of roadway types, volumes and locations (urban, suburban and rural).

All possible roadway segments should theoretically be eligible for sampling. Depending on the size of the target area, the sampling frame may be divided into two or three stages. For example, to measure helmet use in a province, three stages may be employed:

- **Random selection of primary sampling units (e.g. the district or equivalent).** The number of selected primary sampling units should be calculated in proportion to the estimated vehicle kilometres travelled (VKT) for each sampling unit. For example, if the VKT is low in one district, then proportionally fewer sampling units would be selected from that district than for one with higher VKT. If VKT is not available by district, the primary sampling units may be selected using district population.
- **Random selection of roads** within each primary sampling unit, ensuring all road types are represented.
- **Random selection of observational sites** on the selected roads.

#### Number of sites

The actual number of observational sites will depend largely on funding and other logistical issues. If funding is limited it may be more practical to make a greater number of observations from a smaller number of sites. However, consulting a statistician to help determine the appropriate number of sites to give a statistically precise estimate is recommended.

*Continues...*

*Continued from previous page*

### **Site selection**

Ensure that observational sites are selected randomly from all available sites. This may be done by creating a numbered grid, overlaying it on a map and randomly selecting sites from the grid. Exact observation sites should be determined according to the planned protocol before conducting the observations.

Whenever possible, the observation sites should be near intersections where cars slow down, preferably in the absence of a police officer. For example, sites may be selected at signalized intersections where vehicles are stationary and observations of seat-belt wearing are easier to conduct.

Narrow roads are better for observing passing traffic; on wider roads, observations may be taken on one side of the road only, for traffic passing in one direction.

### **Predetermined protocol**

The predetermined protocol should allow for variations in methods for observations or site selection. If traffic volume is too heavy at a particular site to accurately record information, the protocol may state that one observer should observe occupants in the front seats only, while the other observes rear seat passengers. Along with direct observations recorded by observers, a video camera may be used to record traffic flow at sites with heavy flows and where traffic travels at high speeds.

Each site that does not satisfy the selection criteria should have another alternative site on the same road, for example if the original site or time selected is unsuitable due to inclement weather (e.g. heavy rain), if police are in attendance at a particular site or if observations may not be made safely at a site (e.g. due to roadworks).

### **Seat-belt observations**

Project leaders should take safety into account when planning observational work and seek to minimize any likely measurement error.

Observers should be trained beforehand to remove any possible bias. Consider where training takes place, how it is conducted, and who delivers it. Produce a written guideline for observers and others involved in the evaluation and ensure that protocols are adhered to.

Observations may be made by two or more trained observers. Observations may then be later compared to assess level of agreement between observers.

Identify a safe, convenient location from which to make observations. For safety and security reasons, observers should work in pairs and they should wear reflective vests.

Observations should be made for a predetermined period of time. Time periods should be the same at each site to be able to make comparisons between sites.

Observations of seat-belt use may include such categories as age, sex, seating position and seat-belt present but not worn. Clearly, depending on the volume and speed of traffic at observation sites, it may not be practical to observe and record more information than whether a seat-belt is worn or not worn (e.g. estimation of age of car occupants may be too difficult unless this information is gathered through reviewing video footage).

### **Repeating measurements after the intervention**

Repeat observations should be made by the original observers using the same protocol on the same days and times and at the same sites as measurements made before the programme.

## **2.2.3 Why do people not wear seat-belts and use child restraints?**

A seat-belt and child restraint law is unlikely to be successful if people do not obey it, or understand the reason for it, or are unaware of it. Similarly, if vehicles are not widely fitted with seat-belts, or child restraints are difficult or expensive to obtain, use rates are likely to remain low. Once seat-belts are available it is important to assess attitudes to seat-belt wearing in order to provide targeted information to support

legislation and campaigns. Child restraints, because they are an additional cost, may require campaigns that provide them free, on rental, or at low cost.

### **Public attitudes to seat-belt use**

It is useful to know how people regard road safety generally, and their attitudes to seat-belt wearing in particular. This information can help shape a seat-belt use programme and help decide how much should be invested in raising public awareness about the benefits of seat-belts. The goals of a programme will determine which groups should be surveyed and the questions to be asked. They may include asking the following questions:

- What are people's attitudes to road safety generally?
- Do people understand the benefits of wearing a seat-belt? Public attitudes on seat-belt use and seat-belt laws can therefore also serve as a baseline indicator.
- What is the level of public awareness of the benefits of seat-belts?
- Why don't people wear seat-belts? For example, if it is found that motorists have a negative attitude towards wearing a seat-belt, or if they are unaware of the laws or of the effectiveness of seat-belts against injury, then the programme needs to address these issues.
- Who are those most resistant to using seat-belts? Apart from gauging the public's knowledge and attitudes, this type of information can also help identify which groups are most resistant to using seat-belts, so that the programme can target them to change their attitudes and behaviour. Information on variables such as age, sex, occupation and ethnicity would therefore need to be collected.

For child restraint programmes, similar questions should be asked of parents and caregivers about their attitudes towards child restraints with the added component of cost as a barrier.

### **Where will these data come from?**

Data of this type may have been collected as part of a previous seat-belt programme (see section 2.3.5). There may also be studies conducted:

- by market research firms;
- by universities, nongovernmental organizations or other agencies working in road safety.

If such data are not available, it might be useful to conduct a public opinion survey to collect this information. If the programme is still being developed, there are likely to be time and budget constraints. Therefore, only a preliminary survey is suggested at this stage, and a more detailed one can be undertaken later. In a preliminary survey, it is most useful to focus just on the geographical area and population group estimated to have the highest risk.

### BOX 2.2: **Lack of awareness of risk**

Some studies have found that there is a lack of awareness of the risk to passengers in rear seats in cars that contributes to lower seat-belt wearing rates. For example, a telephone survey of 1148 Israeli adults found that there was a higher perceived need to wear seat-belts in the front than in the rear, and wearing rates in the rear were 35% higher among respondents who believed that they were necessary (8).

A survey of parents with children aged under 11 years in the United Kingdom was carried out to assess

parents' knowledge and use of child restraints. Only 62% said that their child always or usually travelled in a child restraint. The use of restraints was highest for children aged 0–3 years, and lowest for those aged 10–11 years. Nearly half the sample thought that it was safe to start using an adult seat-belt between the ages of 7 and 9 years, showing ignorance of the legal requirement and of the reasons for using a child restraint (9).



### CASE STUDY: **Survey of rear seat-belt use, Oman**

In Oman wearing a seat-belt is compulsory in the front seats but not in the rear. The use of seat-belts in 1066 cars entering a university and hospital campus in Oman was observed to determine the degree of seat-belt wearing in the rear. A seat-belt complying with local traffic regulations was being worn by 90% of drivers and 81% of front seat passengers. However, only 1.4% of back seat passengers wore a seat-belt. Only 4% of children under the age of

5 years were strapped in a child restraint and only 17% of children aged 5–12 years were strapped in. A third (34.6%) of children under 5 years of age were sitting in the front seat. In cars with child occupants, 40% of the time parents wore seat-belts but the children did not. Occupants conformed to the law but behaviour indicated a lack of awareness of the dangers of not wearing seat-belts, especially in the case of children (10).

**NOTE****Some reasons given for not wearing seat-belts or using child restraints**

The following examples of reasons given for not wearing seat-belts or using child restraints have been collected from studies in different countries:

- Seat-belts are uncomfortable or inconvenient.
- Motorists worry that a seat-belt might trap them in a burning car or under water following a crash.
- Drivers think that they can avoid crashes because they are highly skilled.
- Passengers who put their seat-belts on are seen by drivers as criticizing their driving.
- Motorists think that it is better to be thrown clear after a collision.
- Pregnant women don't have to wear seat-belts.
- It is not necessary to wear seat-belts for short trips around town at low speeds.
- Sitting in the rear of a car is safe without a seat-belt or child restraint.
- Children don't like being strapped in.
- It is safe to hold a child on the passenger's lap.
- Child restraints are too expensive.

**BOX 2.3: Some common myths about seat-belts****Myth: Seat-belts are uncomfortable or inconvenient.**

**Fact:** People quickly become used to wearing seat-belts and once wearing becomes a habit there is no discomfort or inconvenience. The imaginary discomfort or inconvenience of wearing a belt the first few times in no way compares to the serious discomfort and inconvenience of motor vehicle crash injury. Newer seat-belts are made so that comfortable movement is possible but they will still lock up in sudden stops or crashes.

**Myth: Drivers in airbag-equipped vehicles don't need to wear seat-belts.**

**Fact:** Airbags provide supplemental protection in frontal crashes by protecting the head and chest from hitting the steering wheel or dashboard, but airbags will not help in a side or rear impact or roll-over crash. An airbag by itself reduces the risk of dying by only 12%, whereas a seat-belt reduces fatality risk by 45–60% (11). Motorists should wear a seat-belt for protection in all types of crashes.

**Myth: Wearing a seat-belt might lead to getting trapped in a burning car or caught in one under water.**

**Fact:** Less than 1 out of 200 traffic-related incidents involve fire or water submersion. The greatest danger is with the impact that precedes the fire or submersion in water. If a car occupant is not using a seat-belt, it is very likely that they will be knocked unconscious or severely injured. Chances of escape are 3 to 5 times better while wearing a seat-belt (12).

**Myth: It is better to be thrown clear of a car in a collision.**

**Fact:** Being thrown from a vehicle is four times more likely to lead to fatal injury in a crash, and three quarters of people who are thrown from the car are killed. The force of an impact can throw someone nearly 50 metres, or 15 car lengths. Seat-belts also prevent a car occupant's head from smashing into the windshield, which could cause spinal damage. The best bet in a crash is to stay inside the vehicle, securely held by the seat-belt (12).

**Myth: Seat-belts can hurt you in a crash.**

**Fact:** Properly worn seat-belts seldom cause injuries. If they do, the injuries are usually surface bruises and are generally less severe than would have been the case without any belt. Studies have consistently shown that injuries in most serious crashes would have been much more severe had seat-belts not been worn.

**Myth: Seat-belts are unnecessary at low speeds and on short trips.**

**Fact:** Of road crash casualties who were not restrained, 70% were travelling at less than 50 km/h. A collision at 50 km/h has the same effect as falling from the fourth floor of a building. Two thirds of crashes happen less than 15 km away from home (13).

**Myth: Wearing a seat-belt in the back is not necessary.**

**Fact:** When a crash happens an unrestrained passenger in the back seat will be propelled against the front seat with a force of several tonnes, crushing the front seat occupant (13).

**Data on availability and cost**

The extent of fitment of seat-belts in the vehicle fleet needs to be assessed in order to establish their availability. It will be important to establish the proportion of vehicles in which seat-belts are fitted, showing front and rear seats separately.

Data on seat-belt fitment may be available from:

- government data on vehicle registrations by date of vehicle registration
- vehicle manufacturers, retailers or importers

- vehicle inspection reports
- retailers and fitters of seat-belts for retrospective fitment.

Older vehicles are less likely to have seat-belts fitted as standard, but newer vehicles are more likely to have seat-belts. If legislation making fitment compulsory has been introduced it will be possible to establish the proportion of the vehicle fleet that has been registered since the legislation was enacted. This is particularly important in countries in which the fleet contains a significant proportion of vehicles that pre-date any introduction of regulations concerning compulsory seat-belt fitment. In this case, it will also be important to assess the availability and cost of retrofitted seat-belts.

Typical indicators on seat-belt fitment are:

- car registrations by date, in particular the proportion registered after any law on compulsory fitment was enacted;
- the proportion of vehicles with front seat-belts;
- the proportion of vehicles with rear seat-belts.

These data will come from vehicle manufacturers, importers and distributors, and from government statistics on vehicle registrations. If suitable data are not available from these sources it may be necessary to contract a market research firm to collect the data if the budget allows. Whereas seat-belts are generally factory fitted to vehicles, rather than being purchased separately, child restraints are usually purchased by parents and are not part of the car's original equipment. The cost and availability of suitable child restraints that are designed for children and infants of different sizes will affect their use. The following questions can be used to gather information on child restraints:

- How many child restraints by type are made and sold in the region over a specific time period?
- Who sells child restraints, and where are these distributors located?
- Is supply sufficient to meet demand, and is there a sufficient range of restraints for all age groups and sizes of children?
- What is the average cost of the different types of restraints?
- Are there any loan schemes available?

Data will come from retailers and manufacturers; road safety and other organizations involved in child safety; local government and voluntary organizations that operate loan schemes; and surveys of parents.

The data collected on all aspects of seat-belt wearing will be used for baseline indicators, against which the effectiveness of the programme can be monitored, or for designing and targeting programmes to increase wearing rates. The availability of seat-belts will be a factor in deciding how quickly to phase in enforcement of seat-belt use laws, if this is one of the objectives of the programme (see Module 3).

## **2.3 How to assess what is already in place**

It is important to assess what laws and regulations on seat-belt use exist in the project area, how they are implemented and whether or not they are enforced. For example, if despite a law mandating seat-belt use among car users and a defined national seat-belt standard the seat-belt wearing rate is low and many vehicles do not have seat-belts that conform to regulations, it would be a fair indication that the laws and regulations are not working, or that the enforcement of these laws and standards is inadequate.

Assessing what is in place in a country with regard to existing or previous seat-belt programmes will help to identify the key organizations or people – within government, in the private sector and in civil society – that should be involved in a seat-belt or child restraint programme. They will also point to the main sources of potential political and financial support. As mentioned, this assessment can be conducted at different geographical levels (e.g. country, province or state, town or community) and this should be agreed upon before starting.

The areas described in the following sections need to be examined.

### **2.3.1 Who is in charge of road safety, and what funds are there for it?**

Describing the general situation in the country is a first step to assessing the situation and whether there is a place for a seat-belt programme. How such a programme is then implemented will depend on the country's political system. It is also important to consider whether existing laws encourage seat-belt use, and whether there are funds set aside for road safety programmes that could include seat-belt use initiatives. The following further list of questions will help formulate an overall picture of the situation.

- Is there a centralized, regional or federal system of government? Is there provision in the constitution or in national laws for decentralization? If so, to what extent do local authorities engage in decision-making and making funds available?
- Which are the main government departments – such as those of transport, health, justice and the police – involved in road safety decision-making and what role does each department play?
- What is the current budget for road safety in the country? Are there priorities in the budget for future improvements in the field of road safety? Are there funds that might be accessed for a seat-belt programme?



Nongovernmental and private organizations that could contribute to a seat-belt programme include:

- international organizations and funding agencies, such as WHO, the World Bank, the Global Road Safety Partnership, the FIA Foundation, and other bodies with road safety expertise, as well as those with funding capabilities;
- private consulting firms;
- domestic nongovernmental organizations, including road safety groups and motoring clubs;
- manufacturers and distributors of motor cars;
- major employers, particularly where staff use cars in their work, and on journeys to and from home.

Many countries have a national road safety policy or plan providing a strategic output on delivering better road safety. There are also many local-area projects with specific aims and objectives. In order for seat-belt programmes to have the greatest effect, a coordinated approach should be taken. Therefore, local-area initiatives should be encouraged to complement the programme established and delivered at a national level.

The importance of linking seat-belt and child restraint programmes to national policies and action plans cannot be overstated. This confirms commitment to the programme and aids its implementation. It will also identify clear targets for success and provide the direction required to achieve the aims and objectives of a programme.

National campaign organizers should aim to facilitate coordination by providing local campaign organizers with adequate warning of initiatives, possibly through a published calendar, in order to intensify the effect of the road safety message. National launches of campaigns can also help to bring about a realization that there is a coordinated drive to increase seat-belt use.

Significant results cannot be achieved simply by initiating a national campaign. It requires the assistance of local practitioners in delivering and reinforcing the message. Government agencies are more likely to have the funds to produce resources and expensive national advertising. Local-level practitioners are in a better position to distribute resources to the target audience at ground level to reinforce the national message. Local initiatives may also be guided by targets established at a national level. These are more likely to be aimed at reducing road death and injury in general; however, the plan or strategy should define how these casualty savings should be made. This may include increasing seat-belt wearing rates.

### 2.3.2 Who are the stakeholders?

A stakeholder analysis sheds light on the social environment in which the policy will be developed and implemented. Its primary function is to identify all possible partners who might have an interest in addressing seat-belt and child restraint use, including those who might initially oppose efforts to increase seat-belt use or to mandate seat-belt wearing in the region. Potential stakeholders include government departments, nongovernmental organizations and institutions that will be affected (positively or negatively) by the new law or standards, local communities, formal or informal groups, as well as individuals (e.g. representatives of workforces, victims of crashes). Stakeholders might also include vehicle manufacturers who might be affected by a new law, regulators, industry bodies and associations, importers and exporters.

The second important function of the analysis is to examine the remit of all of the stakeholders, and to understand the relationships between them. A careful analysis should be made of the influence, importance and interests of all major stakeholders, as this will facilitate the design of appropriate approaches for involving them. It is especially important to identify supporters and opponents and, moreover, to appreciate the reasons for their respective positions so as to be able to develop a marketable package that satisfies all parties concerned.

With these comments in mind, the key objectives of a stakeholder analysis are thus:

- to identify key stakeholders, define their characteristics and examine how they will be affected by the policy (e.g. their specific interests, likely expectations in terms of benefits, changes and adverse outcomes);
- to assess their potential influence on the development, approval and implementation of a seat-belt programme;
- to understand the relationship between stakeholders and possible conflicts of interest that may arise;
- to assess the capacity of different stakeholders to participate in developing a seat-belt programme and the likelihood of their contributing to the process;
- to decide how they should be involved in the process to ensure the best possible quality and viability of the programme, in particular:
  - the nature of their participation (e.g. as advisers or consultants, or as collaborating partners);
  - the form of their participation (e.g. as a member of the working group, or as an advisor, or sponsor);
  - the mode of their participation (e.g. as an individual participant or as a representative of a group).

A more in-depth discussion on conducting a stakeholder analysis can be found in *Developing policies to prevent injuries and violence: guidelines for policy-makers and planners (II)*.

**NOTE****What opposition might be expected in putting in place a seat-belt programme?**

Anticipating opposition or constraints to establishing a seat-belt programme is useful to pre-empt these problems arising. Opposition might arise due to:

- competing priorities among policy-makers
- lack of financial resources
- strong lobbying by groups opposed to increasing seat-belt use
- opposition to higher standards from commercial interests.

**2.3.3 Is there a seat-belt use law in place?**

As already stated in this section, it is important to know what road safety laws exist and whether they are adequately enforced. Experience has shown that road safety legislation without proper enforcement is unlikely to have the desired effect. In part, this is because road users do not always recognize the risks involved and the benefits to them of the protective measures contained in the legislation. For this reason, they do not always support laws designed to improve their own safety on the roads.

A seat-belt programme may require the creation of a new law or the modification of an existing one. On the other hand, the existing law may be satisfactory, but may not be properly enforced. Most countries today have some type of law on seat-belt use. It is therefore useful to begin by reviewing the current state of the laws, as shown in the following checklist:

- What current laws relate to road safety generally?
- Is there a specific law on seat-belt use? If so, does it apply nationally or locally? Is it up to date?
- To whom does the law apply – for example, to all drivers and passengers, and all age groups? Are there specified exemptions?
- Does the law apply to all types of road?
- Does the law specify the type or standard of seat-belt or child restraint that should be worn?
- What are the penalties for not complying with the law?
- Is the law enforced? Is it enforced everywhere, and among all motor vehicle users?
- How is a new law officially adopted by the government? What are the mechanisms of endorsement?

### BOX 2.4: The UNECE survey of seat-belt use and legislation

The United Nations Economic Commission for Europe (UNECE) Working Party on Road Safety (WP1) carried out a survey on seat-belt use and legislation for all its member countries and for a number of African countries in 2005. The survey covered both adult seat-belts and child restraints, and it collected information on the following topics:

- collection of information on seat-belt use
- legislation on the equipment of vehicles with seat-belts
- legislation on seat-belt use
- exemptions from mandatory use
- enforcement of seat-belt legislation
- education and campaigns
- evaluation and research on seat-belt wearing
- types of child restraints and legal requirements for their use.

The questionnaire used in the survey is in Appendix 1 and the results can be found on the UNECE website (14).

### BOX 2.5: Seat-belt and child restraint wearing legislation in Latin American countries

The Organización Panamericana de la Salud or OPS (Pan American Health Association or PAHO) has published a review of safety legislation in Latin American countries that summarizes the legislation on seat-belt wearing.

#### Car occupants

- Compulsory seat-belt wearing for driver and front seat passengers: Argentina, Chile, Colombia, Cuba, Dominican Republic, El Salvador, Mexico, Panama and Uruguay.
- Compulsory seat-belt wearing for all car occupants: Brazil, Costa Rica, Ecuador, Peru and Venezuela.

#### Children

##### (a) Seating position

It is compulsory for children to travel in the rear seats of cars at the following ages:

- 12 or younger: Argentina, Brazil, El Salvador and Uruguay
- 10 or younger: Colombia and Venezuela
- 8 or younger: Dominican Republic
- 5 or younger: Mexico

- No legislation: Bolivia, Chile, Cuba, Ecuador, Guatemala, Honduras, Panama, Paraguay and Peru.

##### (b) Rules for child restraints

- Costa Rica: Child restraints are compulsory for children that are 4 years of age or younger.
- El Salvador: Child restraints are compulsory for children that are 2 years of age or younger with a weight not exceeding 15 kg.
- Brazil: Children that are 12 years of age or younger and less than 1.5 metres (m) tall are to be restrained into a system according to their weight. If no child restraint is available in the car, children younger than 3 years of age should be restrained by a seat-belt. Children younger than 3 years of age must travel in a child restraint according to their weight and height.
- Colombia: Children that are 2 years of age or younger are to travel always in the back in a child restraint system that can be fixed to the car seat.

In some cases the regulations are not national but regional, as in the case of Uruguay, or they apply to certain types of vehicles, such as public transport buses in Paraguay (15).

### 2.3.4 Is there a seat-belt and child restraint standard in place?

It is also very important to know whether the seat-belts and child restraints that are available meet approved standards. Such standards might be set by a national body or an international one (see Module 4). Cars should be sold with evidence that seat-belts are fitted that meet such standards and there should be an active process of checking seat-belts for compliance with set standards. There should be a system for ensuring that the child restraints available for purchase meet specified standards. The following questions need to be asked:

- Is there a national or international standard specified that seat-belts and child restraints should meet?
- Do currently available seat-belts and child restraints meet the standard?
- Do vehicle manufacturers abide by this standard?
- Do motor vehicle users wear seat-belts that meet such a standard?
- Are these seat-belts suitable for local conditions of heat and humidity?
- What is the cost of child restraints that meet recommended standards?

### 2.3.5 Have any seat-belt and child restraint programmes been attempted so far?

In most places where motor vehicle use is high or increasing, some measures have already been taken to increase the level of seat-belt use among motor vehicle users. Many countries have mandatory seat-belt laws and public awareness campaigns that promote seat-belt use. Before launching a new programme it is important to be aware of these programmes, laws and campaigns and examine whether they have been effective and whether they could be improved. Such a review can reduce costs and can suggest better ways to carry out future interventions.

The following checklist may be useful in finding out about what has already been implemented:

- Are there any other seat-belt or child restraint programmes currently in place in the country, or a neighbouring country?
- Who are the stakeholders of these programmes?
- Are there seat-belt use or child restraint programmes that have been conducted in the recent past?
- What were the outcomes of these programmes? Are the results available?
- What were the obstacles or constraints to these programmes? What lessons can be learnt?

Table 2.2 summarizes the actions that may be taken to assess the current situation concerning seat-belt and child restraint usage.

**Table 2.2 Summary of actions for assessing the current situation concerning seat-belt and child restraint usage**

<b>Monitoring measures</b>	<b>Details</b>
<b>Analysis of casualty data</b>	Identification of the real problem facing the country. Determine seat-belt and child restraint usage rates of road casualties. Calculate the savings (humanitarian and economic) that can be made from increased use
<b>Assess existing manufacturing standards and legislation</b>	Determine the adequacy of any existing standards and legislation designed to control the fitting and maintenance of seat-belts and child restraints in vehicles  Identify any gaps in standards or legislation
<b>Assess existing wearing legislation</b>	Determine the adequacy of existing legislation designed to enforce the use of seat-belts and child restraints  Identify any gaps in legislation
<b>Capacity to regularly test and monitor the condition of seat-belts</b>	Assess the capacity to undertake annual statutory vehicle tests that include checks on the condition of seat-belts
<b>Observed wearing rates</b>  To highlight the percentage of vehicle occupants wearing seat-belts and child restraints at a national or state level  A sample survey form can be found in Appendix 2	A visual assessment of wearing rates, representing all types of road  Conducted at regular intervals – recommended every 6 months  Using the same sites in selected areas of the country/state for each assessment  Weekend and weekday assessments  Observers need to indicate sex, seating position, approximate age, type of vehicle, if child restraints and seat-belts are installed, and if they are being worn
<b>Stakeholder analysis/market research</b>	Surveys indicating road vehicle occupants' level of awareness and knowledge of seat-belts and child restraints and their benefits  Assessment of casualty statistics  Determine reasons for non-use
<b>Child restraint sales</b>  To indicate any increase in the purchase of child restraints	Number of child restraints sold by type
<b>Vehicles sales</b>  To establish the percentage of vehicles in use that have seat-belts installed	Number of vehicles imported with or without seat-belts installed  Sales of new vehicles with seat-belts installed – may be affected by legislation
<b>Convictions</b>  To be used post-legislation, to indicate levels of effective enforcement	Analysis of criminal statistics relating to vehicle occupants in court for non-compliance with seat-belt legislation

### 2.3.6 Using the situational assessment to prioritize actions

Once the situation has been assessed, the process of prioritizing actions can begin. In many countries, injury prevention and road safety are not recognized as major health and development issues that require political backing. As a result, in these places, a network of key groups with a common interest in road safety needs to be created in order to develop programmes to increase the use of seat-belts and child restraints. Research has shown that when many groups are involved in improving road safety, and successfully share the responsibilities, the effects are much greater (16, 17). What actions to take will depend on where the country is in relation to restraint awareness, campaigns and legislation. Once this has been determined using the information obtained, as explained in this module, and using the summary of actions in Table 2.2, stakeholders will be in a position to identify what is required.

A big factor in prioritizing these actions will be the funds and resources available to deliver and support the actions undertaken. For example, in some countries national television and radio is owned by the government and therefore advertising can be inexpensive. However, in countries where television and radio is not government owned, advertising can be a significant drain on the resources available.

However, educating the public is imperative at the outset of any new promotion, service or product, and seat-belts and child restraints are no exception. Vehicle occupants need informing and then re-educating to generate acceptance of the benefits of wearing a seat-belt. Continuous education is also necessary for future generations.

## Summary

Before designing and implementing a seat-belt or child restraint use programme, a situational assessment must be conducted. Asking a number of the questions listed in this module can help identify the particular problems around seat-belt use in the country, make a strong argument in support of the programme and provide indicators that can later be used to judge a programme's success. The extent of the problem of non-use of restraints needs to be assessed. This involves collecting data on road crashes and injuries, as well as on restraint wearing rates and reasons for non-use. This information can be used as baseline information and to identify the main needs of the programme. Some of this information may also be used in an evaluation of the project.

An analysis of what is already in place with regard to seat-belt and child restraint use needs to be conducted. This involves examining who is in charge of road safety in the country or area, the financial resources available for seat-belt use programmes, the legal instruments already in place, whether a seat-belt standard is specified and what other programmes are in place already or have been conducted in the region or country.

## References

1. *Improving car safety through accident research*. Co-operative Crash Injury Study web site (<http://www.ukccis.org>, accessed 6 November 2008).
2. Broughton J, Walter L. *Trends in fatal car accidents: analyses of CCIS data*. Transport Research Laboratory PPR172, 2007.
3. Holder Y et al., eds. *Injury surveillance guidelines*. Geneva, World Health Organization, 2001 (<http://whqlibdoc.who.int/publications/2001/9241591331.pdf>, accessed 6 November 2008).
4. *Malaysia burden of disease and injury study*. Malaysia Institute for Public Health, Ministry of Health, 2004.
5. *Statistical report: road accidents of Malaysia*. Royal Malaysian Police, 2003.
6. Lewis J, Aguh N. *An assessment of seat belt compliance: before study*. GRSP Ghana Project Report, 2006.
7. Broughton J. *Seat belt wearing rates in cars in England 1982–2002*. Transport Research Laboratory Report TRL 580, 2003.
8. Ressler WH. Why don't more Israelis wear seat belts in the back seat? *Public Health Review*, 1997, 25(2):151–159.
9. *Child car safety restraints research report*. BMRB International Ltd, 2003 (<http://www.dft.gov.uk/pgr/scienceresearch/otherresearch/think/childcarsafetyrestraintsrese1921?page=1#a1000>, accessed 6 November 2008).
10. McIlvenny S et al. Rear seat belt use as an indicator of safe road behaviour in a rapidly developing country. *Journal of the Royal Society for the Promotion of Health*, 2004, 124(6):280–283.
11. Schopper D, Lormand JD, Waxweiler R, eds. *Developing policies to prevent injuries and violence: guidelines for policy-makers and planners*. Geneva, World Health Organization, 2006.
12. *National Highway Traffic Safety Administration Buckle Up Campaign*. Washington, DC, United States Department of Transportation, 2006.
13. La Prévention Routière International (<http://www.lapri.org>, accessed 6 November 2008).
14. *Synthesis of replies to the questionnaire on increasing the use of seat belts and Synthesis of replies to the questionnaire on child restraints*. United Nations Economic Commission for Europe, WP1, Road Traffic Safety.
15. Castiglione C, Bolis M, Concha-Eastman A. *Lesiones no intencionales: legislación de America Latina sobre programas preventivos y responsabilidades*. Organización Panamericana de la Sud, 2004.
16. Lonero L et al. *Road safety as a social construct*. Transport Canada Report 8080–00–1112. Ottawa, Northport Associates, 2002.
17. Tingvall C. The zero vision. In: Van Holst H, Nygren A, Thord R, eds. *Proceedings of the first International Conference: transportation, traffic safety and health: the new mobility*. Gothenburg, Sweden, 1995. Berlin, Springer-Verlag, 35–57.



# 3

**How to plan and manage  
a seat-belt programme**

<b>3.1 How to establish a working group</b> .....	57
3.1.1 Who to involve? .....	58
3.1.2 Assigning roles to working group members .....	59
<b>3.2 How to prepare and promote an action plan</b> .....	61
3.2.1 Setting the programme's objectives .....	61
3.2.2 Setting targets .....	62
3.2.3 Choosing performance indicators .....	63
3.2.4 Deciding on activities .....	64
3.2.5 Setting a time frame and phasing the programme .....	64
3.2.6 Estimating resource needs .....	69
3.2.7 Setting up a monitoring mechanism .....	72
3.2.8 Ensuring sustainability of the programme .....	73
<b>Summary</b> .....	74
<b>References</b> .....	75

**MODULE 2** described how to assess the seat-belt situation in a country, which is the first stage in developing a seat-belt programme. Module 3 describes how to use the assessment information to plan and manage a programme to increase seat-belt use. Module 4 gives detailed information on how to design and implement individual interventions.

The two sections in this module cover:

**3.1 How to establish a working group.** This is an essential step to ensure overall coordination of the programme with input from all the main groups and individuals involved.

**3.2 How to prepare a plan of action.** Based on the assessment that was conducted in Module 2, this section explains how to set objectives, define targets and decide on the activities to meet those targets. It also explains how to estimate a budget for the plan and define a mechanism for monitoring and evaluation. The section also addresses the need to ensure the programme will be sustainable.

### **3.1 How to establish a working group**

Having produced evidence that low seat-belt usage is a problem in the country or region, it is crucial that representatives of the team make a strong case to politicians and decision-makers to obtain their commitment and support.

Once there is sufficient support, a working group of key stakeholders should be established, usually under the leadership of the country's lead agency for road safety, or by a city or state government administration. Its goal will be to coordinate the development and delivery of a multisectoral programme to raise seat-belt wearing levels. Even if there is no clear lead agency for road safety it is important that one government agency takes on board the responsibility for leading the seat-belt programme and that it has the capability to coordinate the work of all sectors involved.

Establishing an effective working group is stage 2 of the programme development and implementation process (see Figure 3.1) and this section gives guidance on which stakeholders to engage and what roles should be adopted by the group.

**Figure 3.1 Stage 2: establishing a working group****Module 3**

- Appoint under capable lead agency for road safety
- Engage key stakeholders based on stakeholder analysis
- Win necessary support, coordinate the development and implementation of a national or local programme and action plan to implement it

**3.1.1 Who to involve?**

The overall assessment of the country situation (Module 2) includes steps on how to conduct a stakeholder analysis. This should indicate the best people to approach – from within government bodies and other organizations – to participate in the seat-belt safety programme. In particular, it should identify the main political figures to be involved and the best way to mobilize financial support and community backing, as well as those with the relevant technical expertise.

The working group should draw on the expertise and experiences of a range of individuals, including:

- members of the lead agency;
- representatives from relevant government agencies, such as those of transportation, health, police, education and law enforcement;
- public health and injury prevention specialists;
- health-care professionals;
- independent researchers;
- nongovernmental organizations, including those representing victims of road crashes;
- members of motoring organizations;
- seat-belt, child restraint and vehicle manufacturers;
- engineers and other specialists;
- large employers and managers of large car fleets.

Each of these partners has an interest in the outcome of the seat-belt programme and each can help develop, implement and evaluate an action plan. Many of these partners will already be involved in road safety work and are therefore likely to be aware of at least some of the issues around seat-belts and their use.

Ideally, the working group should also include those who might be critical of a seat-belt programme. Their position needs to be understood as well, so that a programme is devised that addresses possible objections and is acceptable to the widest possible segment of society.

To work well, a multisectoral working group should have well-defined working procedures and a clear workplan, extending to the eventual implementation. It is important to have good communication within the group. To this end, there should be someone within the working group responsible for disseminating information among the various members.

Because of the different technical inputs required it may be best to set up an organization with a management committee and subgroups focusing on legislation, standards, enforcement and public information, as illustrated in Figure 3.2.

**Figure 3.2** Example organizational structure of working group and possible tasks

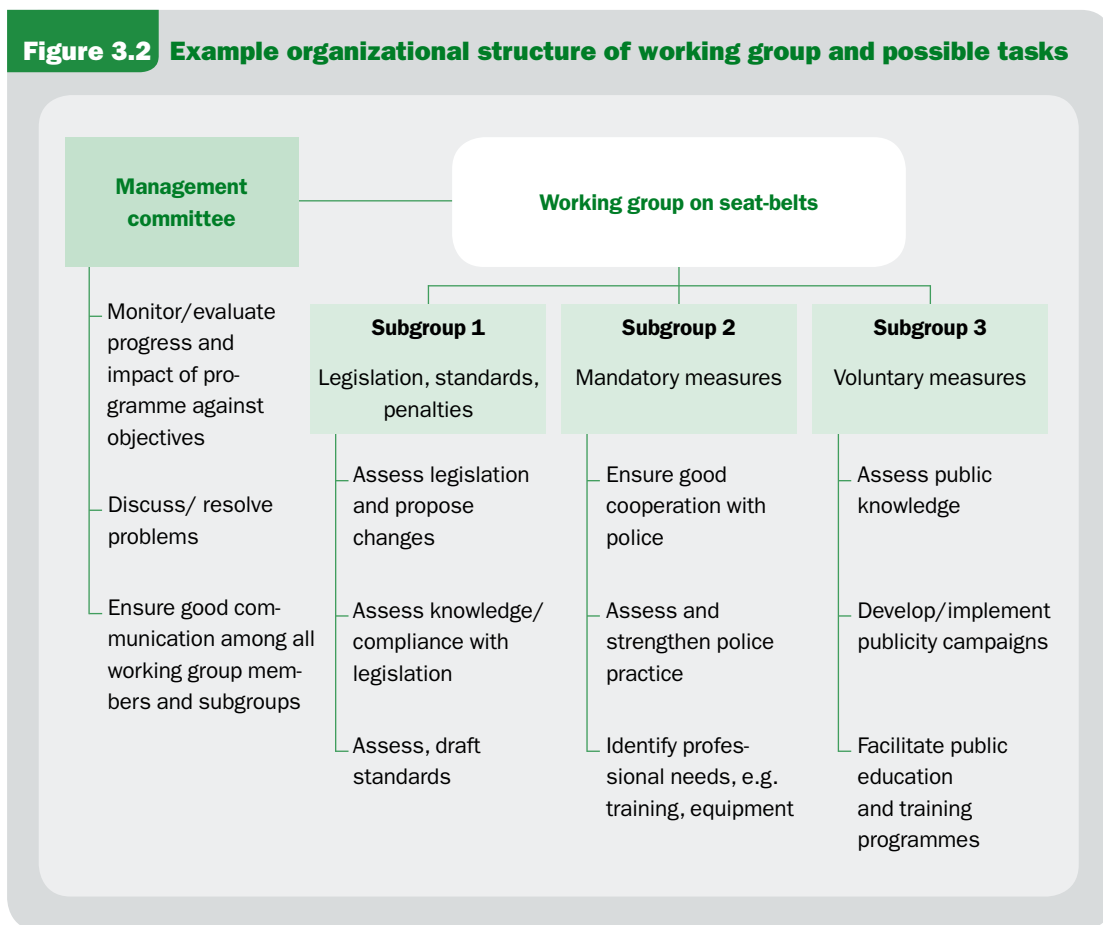

### 3.1.2 Assigning roles to working group members

Certain functions will be common to all well-organized seat-belt programmes. These include the initiation of the programme – its conceptualization and launch, the operation itself, its coordination and the function of advocacy. Those who are specifically assigned to these functions are described here because of their special roles. Sometimes, one person or agency may fulfil more than one function.

### **The initiator**

The person or agency initiating the activity does not need to be engaged in the way that others who are involved are. However, the initiator must fit into the operation to ensure that the programme moves forward in a coordinated manner. The enthusiasm of the initiator should be harnessed to the benefit of the programme.

### **The operators**

The operators have the technical responsibility for carrying out various aspects of the programme. Frequently, they will be officials of the lead and subsidiary agencies involved, such as the department of transport, the ministry or department of legal affairs and the police. They must be allowed to participate fully and their official workload adjusted accordingly. Training and other resources may also be required here.

Operators need to be open to input from others involved in the programme.

### **The coordinator**

The coordinator has overall responsibility for the execution of the programme and their role is critical to its success. The coordinator, whether paid or not, should have clearly defined responsibilities. These include overseeing the activities of the working groups, monitoring progress and ensuring that all those involved, including the initiator and operators, are kept well informed. The coordinator should have full authority to carry out these functions, as well as the resources and the support needed to implement these tasks. For this reason, the role is best filled by someone whose work already includes some of these responsibilities. Such a person may be the chief technical officer within the transport department, the person in charge of the traffic police or a high-ranking official in the health ministry.

### **The advocate(s)**

The advocate champions the cause of seat-belt and child restraint use. This is usually one person or several influential people with good communications skills who are well known and respected. The advocate and coordinator can have several qualities and tasks in common, and in some instances they are the same person. Prominent people who have themselves been affected – generally adversely – by a lack of seat-belt use, or have had their lives saved by the use of a seat-belt, usually make good advocates.

## 3.2 How to prepare and promote an action plan

Before a comprehensive seat-belt programme can be implemented, a plan must be prepared showing what actions and resources are required to achieve the programme targets. This plan must be backed up by data, as described in Module 2. An action plan can be prepared at a national, regional or even town level.

Developing the action plan is stage 3 of the programme development process. The key steps involved are shown in Figure 3.3 and described in turn in the remainder of this section. A more in-depth discussion on developing an action plan for a national policy is found in *Developing policies to prevent injuries and violence: guidelines for policy-makers and planners (1)*.

**Figure 3.3 Stage 3: developing the programme and action plan**

### Module 3

- Set objectives
- Set targets
- Set indicators
- Decide on activities
- Estimate resources
- Set time frame
- Set up monitoring/evaluation
- Use evaluation results as basis for creating next programme to ensure sustainability of increased wearing rates

### 3.2.1 Setting the programme's objectives

Any seat-belt programme should contain specific, measurable, achievable and realistic objectives. The objectives are developed by examining the data collected in the situational assessment. This information must be analysed by the working group to identify the problems to be addressed in the programme. In particular the group should identify the vehicle type that they will focus on and determine which types of occupant they will target, for example front seat, rear seat or children.

In considering appropriate solutions to the problems, the working group should follow a systems approach; that is, one that considers the system as a whole and identifies where there is potential for intervention (2). Solutions are thus likely to include measures that address the user, such as education, as well as enforcement of laws and regulations, design, standards and fitment of seat-belts, all of which are combined over a period of time.

The objectives will, in general terms, be one or more of the following:

- to increase knowledge and awareness of road traffic safety, and seat-belt use in particular;
- to ensure that all new motor vehicles have seat-belts fitted as standard;
- to increase the rate of seat-belt use;
- to improve the quality of seat-belts fitted;
- to decrease the rate of serious injuries and deaths resulting from vehicle crashes, particularly for vehicle occupants.



### CASE STUDY: **Example of a seat-belt programme target, Malaysia**

Malaysia has included increasing rear seat-belt wearing rates for car passengers in its 2006–2010 National Road Safety Plan. The programme started in 2007 with advocacy and informing the public about the importance of wearing rear seat-belts. This was followed by a major multimedia publicity campaign commencing in June 2008 and running

for six months. Enforcement will begin on 1 January 2009. Indicators of expected progress, including estimates of coverage and fatality reduction, have been produced by the Malaysian Institute of Road Safety and are shown below. They will be monitored until the end of 2010.

Programme	% intervention coverage				Potential reduction	No. of deaths	Expected no. of fatality reduction			
	2007	2008	2009	2010	%	Involved/yr	2007	2008	2009	2010
Rear seat-belts	20	40	60	80	30	350	21	42	63	84

### 3.2.2 Setting targets

Once identified, such general objectives should then be made more specific so that the programme has a clear results focus. The objective to increase the rate of seat-belt use, for instance, might be stated as “increasing the rate of seat-belt use by a specified amount, over a given time period”. It is generally preferable to set measurable, time-limited objectives; these can be expressed in terms of a **target**, for example percentage reduction (or improvement) to be achieved by a certain date, as illustrated in the case study from Malaysia (see case study).

Having targets generally results in more realistic road safety programmes, a better use of public funds and other resources, and greater credibility of those operating the programmes (3, 4).

Developing targets will require the use of crash and injury and other related baseline data in order to establish **measurable** objectives. For example, an activity might aim to achieve a 50% increase in seat-belt use over a specified time period. The experience of other initiatives in road safety suggests that targets should be both ambitious



and carried out over a long time period (5). A longer time frame also allows for programmes to be introduced step by step.

Setting targets for the first time will be more difficult as no previous trend exists for modelling the future. However, much can be learned from the experience of other countries and evaluation studies.

Table 3.1 provides some examples of objectives and possible targets. Precise changes and timescales are not specified but would normally be required.

**Table 3.1** Examples of objectives and possible targets for a seat-belt programme

Programme objective	Example performance targets
Increase in driver and passenger knowledge/awareness about seat-belt wearing	<ul style="list-style-type: none"> <li>• % increase in knowledge about the law and the penalties</li> <li>• % increase in knowledge about the benefits of using seat-belts</li> <li>• % increase in awareness of increased enforcement by the police</li> </ul>
Increase fitting of standard driver and passenger seat-belts	<ul style="list-style-type: none"> <li>• National seat-belt standard/regulation approved (for cars, trucks and buses)</li> <li>• % increase in number of vehicles fitted with standard seat-belts (front and rear, trucks and buses)</li> </ul>
Increase wearing levels of seat-belts	<ul style="list-style-type: none"> <li>• Legislation on wearing and penalties enacted</li> <li>• % increase in seat-belt wearing (front and rear, child, trucks and buses)</li> <li>• % decrease in cases registered for seat-belt violations (only after enforcement has already made significant impact)</li> </ul>
Reduce fatalities of drivers and passengers of motor vehicles	<ul style="list-style-type: none"> <li>• % reduction in car driver fatalities</li> <li>• % reduction in fatalities of front seat occupants of cars</li> <li>• % reduction in fatalities of rear seat passengers in cars</li> <li>• % reduction in fatalities of child passengers</li> <li>• % reduction in truck driver fatalities</li> <li>• % reduction in fatalities of unrestrained vehicle occupants</li> </ul>

### 3.2.3 Choosing performance indicators

The previous section explained the importance of setting measurable targets. This section illustrates that there are a number of performance indicators that can be used both for providing a basis for targets and for measuring the progress of the programme.

Typical outcome performance indicators for seat-belt programmes are:

- the percentage of vehicles with seat-belts fitted
- the extent of seat-belt awareness
- the extent of seat-belt use compliance
- the number of vehicle occupants injured or killed.

These can be more detailed to meet the specifications of the programme, for example:

- the seat-belt wearing rate, distinguishing between drivers and passengers and front or rear seating positions (for example, as a proportion of the total number of vehicle occupants in each category);
- a reduction in fitting violations for seat-belts, using data from inspectors' reports.

The performance indicators can also include a wider range of intermediate outcomes, such as the extent of police enforcement of seat-belt laws as measured by the number of police tickets issued.

Performance indicators can also relate to the project outputs, for example:

- the frequency of public awareness campaigns
- the number of police trained in seat-belt enforcement
- the number of organizations adopting seat-belt rules for employees.

When choosing performance indicators it is important to select those that best measure the objectives. Often this will mean an extra effort in collecting data and this must be built into the programme. In order to show changes and improvements resulting from the programme, these data will need to be compared to baseline data and take into account other factors that could have an impact on the programme objectives. For injury and mortality data it is important that the measure is focused on the target group of occupants and that comparisons with overall trends are made.

For each indicator there should usually be a specific quantifiable target, though output indicators may relate simply to completion of a key activity, for example legislation passed by a specific date (see Table 3.1).

### **3.2.4 Deciding on activities**

After specifying the objectives, targets and indicators, the working group must decide on and plan activities. Table 3.2 presents a summary of a number of elements that could be included in a seat-belt programme. To help planners prioritize the key activities the table provides simple indications of their relative effectiveness, ease of implementation, cost and whether there is research to demonstrate the effectiveness of the interventions. Information is also provided on the relevant sections in the manual (mostly Module 4) where there is more detailed information on how to design and implement these components.

### **3.2.5 Setting a time frame and phasing the programme**

An action programme to promote seat-belt use will include both preparatory steps, involving legislation, standards and design; and launching steps, which ensure compliance with the laws and regulations through incentives and enforcement. The timing of each step should be considered when planning the project.

**Table 3.2 Possible programme elements by priority for countries implementing a seat-belt programme**

Element	Description	Research	Effectiveness	Difficulty to undertake	Cost to implement	Section in this manual
Road safety/crash data assessment	A situational or needs assessment is crucial for planning the programme and for convincing decision-makers of the need for action and resources.	Yes	High	Low	Low	2.1, 2.2, 2.3
Laws on seat-belts and child restraints	The overall objective of seat-belt laws is to make seat-belt use universal. In the case of seat-belts, legislation needs to deal with: <ul style="list-style-type: none"> <li>• Seat-belt fitting by vehicle type and inspection;</li> <li>• Seat-belt wearing by vehicle type, passenger location, children;</li> <li>• Penalties for non-compliance (must be serious enough to deter non-compliance).</li> </ul>	Yes	High when backed up by strong enforcement	Low if there is political commitment	Low	4.2
Standards for seat-belt equipment and fitting	As evidence shows that half or more of vehicles in low-income countries may lack proper functioning seat-belts (6), it is vital that proper standards are established for seat-belts and the way they are fitted.	Yes	High if compliance monitored	Low	Low	4.3
Strong enforcement of seat-belt laws	The most effective enforcement is a strong, visible and intelligence-led approach at locations and times that maximize desired impact and meet safety requirements for stopping vehicles. Intensive enforcement programmes should be preceded by publicity and information campaigns, possibly with a warning phase before prosecutions start. Penalties should be applied swiftly and consistently without discretion and can be included in a penalty points system.	Yes	High	Low needs reasonable public support at the outset	Medium	4.4
Publicity campaigns	Publicity is a crucial component for preparing the public for enforcement campaigns, especially for new seat-belt laws. On their own, publicity campaigns will have a limited impact on seat-belt usage and they should be supported by an effective enforcement strategy.	Yes	High in combination with legislation and enforcement	Medium	High	4.6

Continued...

High priority

Continued from previous page

Element	Description	Research	Effectiveness	Difficulty to undertake	Cost to implement	Section in this manual
High priority	Education and training	Yes	High in combination with legislation and enforcement	Medium	Medium to high	4.7.2
	Monitoring and evaluation	Yes	High	Medium	Medium to high	5.1, 5.2, 5.3
	Seat-belt testing and certification programmes	No	Medium	Medium	Medium	4.3.3
Medium priority	Vehicle inspection systems and seat-belt maintenance	No	Medium	Low	Low	4.3.4
	Insurance schemes	No	Medium	Low	Low	4.7.3
	Employer programmes	No	Medium	Low	Low	4.7.1

The sequence of actions is important; some key recommendations are shown in Box 3.1.

#### BOX 3.1: **Sequence of actions in a seat-belt programme**

1. Start with legislation on seat-belt fitting before seat-belt wearing.
2. Start the process of adopting seat-belt standards (regulations) as soon as possible but do not let it hold up the legislation process.
3. Always inform the public about new legislation or enforcement practice before changing enforcement practice.
4. Try to combine information and publicity activities with enforcement, as an integrated approach is much more effective than either of these activities in isolation.
5. Consider a phased approach in the long-term programme, e.g. start with cars, then buses and trucks.

Phasing should also be considered in the long-term programme. This particularly relates to legislation when countries may wish to tackle front occupants of cars before rear seat occupants, and before child restraints, followed by bus and truck occupants. Phasing of legislation is dealt with in more detail in section 4.2.6.

The time frame will depend on activities agreed upon. For example, if legislation is to be developed and implemented, a decision may be taken to phase in enforcement of the new law gradually in different areas (see section 4.4.2). However, clearly an overall timeline must be agreed upon at an early stage in the planning process, as this may be affected by the availability of resources.

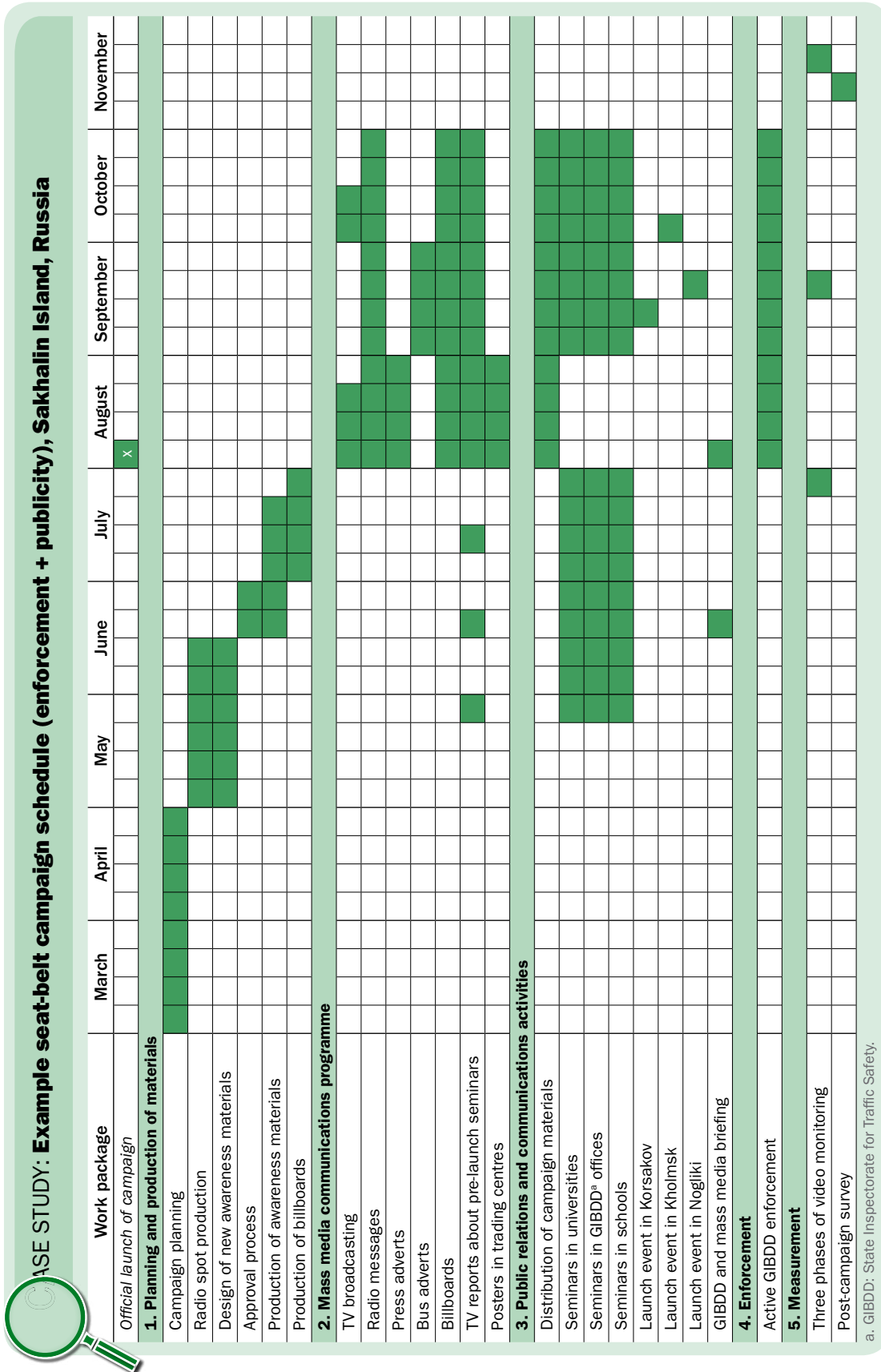

a. GIBDD: State Inspectorate for Traffic Safety.

### 3.2.6 Estimating resource needs

There will be an inevitable need for initial and sustained investment in order to ensure a coordinated approach to increasing seat-belt usage. Costs will be incurred throughout the design of legislation, including the consultation process.

As part of designing the programme, it is therefore important that the following steps are taken:

- The human resource needs, including training, should be estimated.
- The costs of implementing the programme must be broken down by component and by activity chosen.
- National and international funding sources must be identified. Ideally, ministries who will be involved in implementing the programme should adjust their budgets to reflect the new activities. Alternatively, the working group can try to secure financial support from donors.

Failure to fully address resource needs for implementation during the planning stage can jeopardize the future success of the programme. Thus it is important that the working group is realistic in estimating the likelihood of securing the funding needs of the programme.

Having planned the programme activities in detail, the working group can now estimate the cost of each activity and in the process draw up a budget, based on quotes from suppliers or on the cost of recent similar undertakings.

When formulating budgets, the following actions are recommended:

- estimate the funds available for the duration of the project;
- set priorities, with activities phased if necessary to ensure that priority activities receive adequate funding;
- discuss, with other government departments, non-profit-making organizations and private sector firms, similar projects already undertaken and their costs;
- estimate the likely administrative and operational expenses in implementing the programme;
- estimate the cost of monitoring and evaluation;
- plan for financial reports at regular intervals.

It is essential that the government has ownership of the programme and finances it. Table 3.3 provides an example of a seat-belt campaign budget. Table 3.4 and the case study from Fiji on road safety levies provide some suggestions on how to finance a seat-belt campaign.

**Table 3.3** Example seat-belt campaign budget (US\$, VAT inclusive)

Seat-belt publicity campaign budget breakdown for a group of smaller cities (400 000 population) for 2005

No.	Item	July	Aug	Sept	Oct	Nov	20 Dec <sup>a</sup>	Total
<b>1</b>	<b>Mass media<sup>b</sup></b>							
1.1	TV broadcasting				5 000	4 700	4 900	14 600
1.2	Radio				2 000	2 000	2 000	6 000
1.3	Printed media, news agencies, Internet	3 500			5 400	5 200	5 500	19 600
<b>2</b>	<b>Public relations activities and educational campaign</b>							
2.1	Educational campaign				14 000	9 000		23 000
2.2	Public relations activities				5 500	2 500	500	8 500
<b>3</b>	<b>Advertisements and printing production</b>							
3.1	Production of advertising materials	2 250	5 250	2 800	2 000	1 500	500	14 300
3.2	Outdoor advertising			4 000	6 950	5 950	700	17 600
<b>4</b>	<b>Analytical, organizational, creative work</b>	6 300	9 600	9 350	5 800	3 800	3 300	38 150
<b>5</b>	<b>Total as per block</b>	12 050	14 850	16 150	46 650	34 650	17 400	141 750
<b>6</b>	<b>Agency fee</b>							21 250
<b>7</b>	<b>Technical expenses<sup>c</sup></b>							9 250
<b>8</b>	<b>Incidental expenses, unanticipated needs</b>							7 750
	<b>Total</b>							<b>180 000</b>

a. Preliminary date.

b. Broadcasting information messages in news blocks and interviews are presumed to entail no cost.

c. Includes, for example, hotel, office (four work positions), office equipment, transport, cellphones, per diem allowance, air travel.



**Table 3.4** Possible ways to fund a seat-belt wearing campaign

Source of funding	Method of funding
Reinvestment	Some of the money from fines for non-compliance can be reinvested in a central fund to support public education and to help train the police to enforce the law. Similarly, funds from fuel tax, vehicle licence and registration fees can be earmarked for particular purposes related to the seat-belt programme. A road safety levy could be incorporated into insurance premiums and allocated to the central collision prevention fund. If used, the World Bank recommends a tariff equivalent to 8% of premiums.
Sponsorship	Corporate groups often sponsor activities they see as worthwhile, and they may fund a seat-belt programme or specific components of it. Companies involved in manufacturing vehicles, or those selling insurance, may benefit by being seen as major sponsors of a seat-belt wearing campaign. Stakeholders should explore whether there could be any legitimate tie with vehicle or seat-belt manufacturers. This may produce further sponsorship for related campaigns, but may also allow the opportunity for discounts so owners, particularly those in less affluent social groups, can afford to fit seat-belts to unfitted older vehicles.
Donor organizations	Development aid agencies and other charitable organizations are possible sources for funding a seat-belt programme. In a similar way, road safety organizations and educational bodies may provide funding or contribute technical expertise.

**CASE STUDY: Examples of road safety levies**

Voluntary financial donations are given every quarter by the motor insurance industry in Fiji. These amount to approximately 10% of third-party premiums and are dependent on the number of new policies. This provides the National Road Safety Council with 60% of its funding.

The Transport Accident Commission (Victoria, Australia) provides funding for road safety through both a mandatory levy and a voluntary levy. Donations started at 3% but have risen to 10%. This

funding for road crash reduction and rehabilitation programmes reduced road deaths by 50% in less than four years (7).

South Africa employs a system whereby third-party injury insurance is collected through a fuel levy. Therefore, each time a vehicle owner or driver purchases fuel or uses their vehicle, they also purchase third-party injury insurance. As a result, non-compliance is virtually non-existent (7).

**NOTE****Who pays? Investing in seat-belt programmes**

Governments and policy-makers must realize that a seat-belt programme requires considerable investment, but that there can be significant economic returns on investment and overall societal benefits through reduced medical costs. Cost–benefit analyses that quantitatively illustrate that financing a seat-belt programme provides value for money may be very useful in gaining political support for a seat-belt initiative. If such studies have not been conducted in a country, it may be necessary to rely on data or examples from similar countries, and to incorporate a cost–benefit analysis into the evaluation of the planned seat-belt programme (see Module 4).

**3.2.7 Setting up a monitoring mechanism**

Monitoring the programme involves keeping a close check on all measurement indicators to ensure the programme is on track towards the goals set out. Evaluation methods are discussed in more detail in Module 5.

Monitoring can be:

- **continuous**, with the lead agency of the working group overseeing the overall programme in case problems arise;
- **periodic**, with activities measured at the end of each stage of implementation.

Table 3.5 gives an example of what might be monitored during a typical seat-belt wearing programme, and the possible actions to take if the indicators suggest that activities are missing their objectives. It is important to:

- define resources for this task: human as well as financial resources should be allocated at the outset of the process to ensure that the monitoring and evaluation takes place at an appropriate time and the results are disseminated;
- define the mechanism for monitoring: setting out who will be responsible for monitoring progress, at what intervals progress should be reported and to whom, and how implementation can be enforced if needed, as early as possible;
- put in place a feedback mechanism to allow the regular revision of a programme, should it be necessary to improve its accuracy and relevance.

**Table 3.5** Monitoring indicators and corrective action

Activity	Indicator(s) for monitoring	Actions to take if monitoring suggests activity is below target
Improving manufacturers & dealers compliance with seat-belt standards	<ul style="list-style-type: none"> <li>• Number of trained inspectors</li> <li>• Number of tests conducted</li> <li>• Number/% of failure reports</li> </ul>	<ul style="list-style-type: none"> <li>• Improve information about standards</li> <li>• Increase number of trained inspectors</li> </ul>
Increasing capacity of police to enforce	<ul style="list-style-type: none"> <li>• Seat-belt wearing rates</li> <li>• Amount of enforcement activity and extent of area covered by enforcement</li> <li>• Number/amount of tickets/fines issued</li> </ul>	<ul style="list-style-type: none"> <li>• Increase size of traffic police force and raise priority given to seat-belt checks</li> <li>• Change enforcement areas and techniques</li> <li>• Improve system of issuing tickets and collecting fines</li> </ul>
Implementing awareness campaign on road safety and seat-belt use	<ul style="list-style-type: none"> <li>• Level of awareness of traffic safety</li> <li>• Level of awareness of benefits of seat-belt use</li> <li>• Level of knowledge of seat-belt laws and their enforcement</li> <li>• Observed (or self-reported) changes in behaviour</li> </ul>	<ul style="list-style-type: none"> <li>• Redefine target audience</li> <li>• Redefine message(s)</li> <li>• Evaluate the means of delivering the messages and change them if necessary</li> </ul>

### 3.2.8 Ensuring sustainability of the programme

The sustainability of a seat-belt programme is essential to ensure that benefits that result from the programme persist. Even when compliance has been raised to high levels there are likely to be certain sections of the population who remain resistant to wearing seat-belts. New generations of drivers need to be made aware of the risks of not wearing a seat-belt. Targeted publicity campaigns as well as sustained levels of enforcement will be needed to ensure that seat-belt wearing rates do not decline.

Successfully sustaining a programme also requires that the components of the programme are evaluated to determine what worked and what did not work (see Module 5). The results of this evaluation should be fed back into the design and implementation of future activities.

It is also important that successes are recognized by congratulating the teams involved and by giving them widespread coverage in the media.

## Summary

A working group should be set up to oversee the formation of a seat-belt use programme. Consisting of individuals from a range of relevant backgrounds and disciplines, this working group will advise on all matters of the programme and ensure the necessary coordination between its different activities. The group should have the authority to carry out the programme.

Once a working group is established, the results of the situational analysis can be used to plan the programme. Activities can then be defined in the areas of legislation, enforcement and education. Alongside each activity, programme goals and objectives should be set.

Funding needs to be secured for the programme so that it can be effectively implemented. Monitoring the programme throughout its various stages is essential, to identify shortcomings and correct them. Finally, an outcome evaluation should be carried out to determine whether the programme has been effective. Based on this, future programmes can be built, sustaining the impact of the initial programme.

Table 3.6 summarizes the main steps in planning and managing a seat-belt programme.

**Table 3.6 Main steps in planning and managing a seat-belt programme**

Activity	Steps in planning and managing a seat-belt programme
Establishing a working group	<ul style="list-style-type: none"> <li>• Ensure all those with an interest are represented</li> <li>• Assign roles to members</li> <li>• Promote and ensure commitment from senior stakeholders</li> </ul>
Developing an action plan	<ul style="list-style-type: none"> <li>• Define objectives</li> <li>• Set targets</li> <li>• Select activities needed to achieve objectives</li> <li>• Define performance indicators for activities</li> <li>• Estimate resources required</li> <li>• Articulate how the programme will be monitored and evaluated</li> </ul>
Ensuring sustainability of the seat-belt programme	<ul style="list-style-type: none"> <li>• Plan for a minimum five-year time frame and even longer-term funding to ensure sustainability of the programme</li> <li>• Use monitoring and evaluation results as the basis for enhancing efforts and planning the next round of activities</li> </ul>

## References

1. Schopper D, Lormand JD, Waxweiler R, eds. *Developing policies to prevent injuries and violence: guidelines for policy-makers and planners*. Geneva, World Health Organization, 2006.
2. Peden M et al. *World report on road traffic injury prevention*. Geneva, World Health Organization, 2004.
3. *Targeted road safety programmes*. Paris, Organisation for Economic Co-operation and Development, 1994.
4. Elvik R. Quantified road safety targets: a useful tool for policy making? *Accident Analysis and Prevention*, 1993, 25:569–583.
5. Elvik R. *Quantified road safety targets: an assessment of evaluation methodology*. Report 539. Oslo, Institute of Transport Economics, 2001.
6. *Primary enforcement saves lives: the case for upgrading secondary safety belt laws*. National Highway Traffic Safety Administration, 2006 (<http://www.nhtsa.dot.gov/people/injury/enforce/PrimaryEnforcement/index.htm>, accessed 16 April 2008).
7. Aeron-Thomas A. *The role of the motor insurance industry in preventing and compensating road casualties*. Crowthorne, United Kingdom, TRL Ltd, 2002.



# 4

**How to develop and  
implement interventions**

<b>4.1 Increasing usage: the combined approach</b> . . . .	81	4.4.7 Section summary: increasing seat-belt usage through enforcement . . . . .	111
<b>4.2 Legislation and penalties.</b> . . . . .	82	<b>4.5 Increasing usage: voluntary measures</b> . . . . .	112
4.2.1 Developing seat-belt fitting and usage laws . . . . .	83	<b>4.6 Increasing usage: publicity campaigns</b> . . . . .	113
4.2.2 Identifying legal responsibilities . . . . .	86	4.6.1 Objectives of the campaign . . . . .	115
4.2.3 Exemptions . . . . .	86	4.6.2 Creating campaign messages . . . . .	116
4.2.4 Penalties for non-compliance . . . . .	87	4.6.3 Reaching the target audience . . . . .	118
4.2.5 Developing and implementing legislation . . . . .	89	4.6.4 Creative concepts . . . . .	119
4.2.6 Phasing implementation . . . . .	91	4.6.5 Selecting an agency for the campaign . . . . .	122
4.2.7 Section summary: checklist for seat-belt legislation . . . . .	92	4.6.6 Working with the media . . . . .	124
<b>4.3 Seat-belt standards and equipment</b> . . . . .	93	4.6.7 Campaign stages in relation to seat-belt legislation . . . . .	124
4.3.1 Adopting a standard or regulation . . . . .	94	4.6.8 Evaluating the campaign . . . . .	126
4.3.2 Types of standards or regulations and their content . . . . .	97	<b>4.7 Increasing usage: other voluntary measures</b> . . . . .	127
4.3.3 Testing and certification . . . . .	98	4.7.1 Employer regulation and incentive schemes . . . . .	127
4.3.4 Vehicle inspection and seat-belt maintenance . . . . .	99	4.7.2 Education and training . . . . .	129
4.3.5 Retrospective fitting . . . . .	100	4.7.3 Insurance and public incentive schemes . . . . .	132
4.3.6 In-vehicle reminder systems . . . . .	102	<b>4.8 How to ensure an appropriate post-crash response.</b> . . . . .	133
4.3.7 Section summary: checklist for developing seat-belt standard or regulation . . . . .	103	4.8.1 Seat-belts and injuries . . . . .	135
<b>4.4 Increasing usage: enforcement.</b> . . . . .	104	4.8.2 Seat-belt removal . . . . .	135
4.4.1 Pre-requirements . . . . .	104	<b>Summary</b> . . . . .	138
4.4.2 Enforcement strategy . . . . .	105	<b>References</b> . . . . .	140
4.4.3 Enforcement methods . . . . .	108		
4.4.4 Police training . . . . .	109		
4.4.5 Processing penalties . . . . .	109		
4.4.6 Overcoming obstacles to enforcement . . . . .	110		



**MODULE 3** provided information on stage 3, how to develop the programme and action plan. It included advice on choosing priority actions and a summary of high- and medium-priority interventions together with an indication of their relative effectiveness, ease of implementation and cost (see Table 3.2).

Module 4 moves onto stage 4 (see figure 4.1) and gives guidance on how to develop and implement each key activity of a programme aimed at increasing seat-belt usage.

**Figure 4.1 Stage 4: develop and implement individual activities**

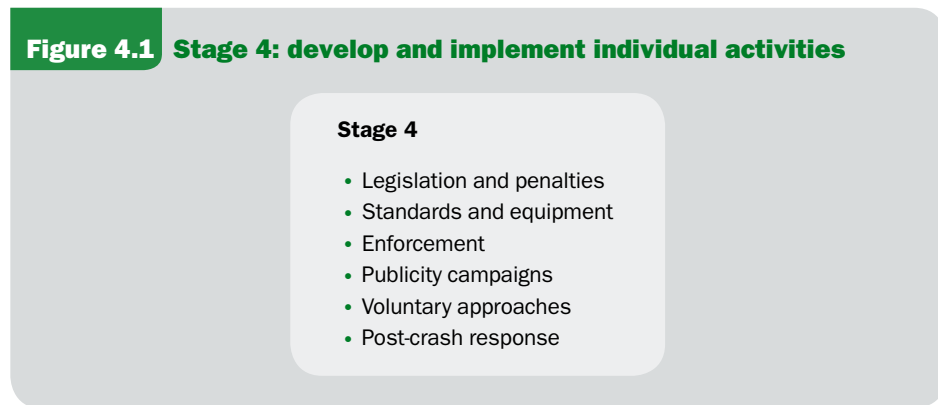

The module stresses the need for an integrated approach combining measures that work well together. It also provides substantial information on each activity and the structure of this activity, as shown in Table 4.1.

Whilst this module gives advice on interventions in respect of seat-belts, it is also applicable to programmes aimed at increasing the use of child restraints. Where there are issues that are specific to child restraints these are also included, but in general, to avoid repetition, reference is made to seat-belts only.

**Table 4.1** A summary of key areas of activity and interventions to be included in a seat-belt programme

Key areas of activity	Guidance provided on:	Section
Legislation and penalties	<ul style="list-style-type: none"> <li>• Developing fitting and wearing laws</li> <li>• Identifying legal responsibilities</li> <li>• Exemptions</li> <li>• Penalties for non-compliance</li> <li>• Introducing and implementing legislation</li> <li>• Phasing implementation</li> </ul>	4.2
Standards and equipment	<ul style="list-style-type: none"> <li>• Adopting a standard</li> <li>• Types of standard</li> <li>• Testing and certification</li> <li>• Vehicle testing and seat-belt maintenance</li> <li>• Retrospective fitting</li> <li>• In-vehicle reminder systems</li> </ul>	4.3
Increasing usage: enforcement	<ul style="list-style-type: none"> <li>• Pre-requirements</li> <li>• Enforcement strategy</li> <li>• Enforcement methods</li> <li>• Police training</li> <li>• Processing penalties</li> <li>• Obstacles to enforcement</li> </ul>	4.4
Increasing usage: voluntary approaches	<ul style="list-style-type: none"> <li>• Publicity campaigns, including:               <ul style="list-style-type: none"> <li>– Objectives of the campaign</li> <li>– Creating campaign messages</li> <li>– Reaching the target audience</li> <li>– Creative concepts</li> <li>– Selecting an agency for the campaign</li> <li>– Working with the media</li> <li>– Campaign stages in relation to seat-belt legislation</li> <li>– Carrying out and evaluating the campaign</li> </ul> </li> </ul>	4.5, 4.6
	<ul style="list-style-type: none"> <li>• Other voluntary approaches, including               <ul style="list-style-type: none"> <li>– Employer regulation and incentive schemes</li> <li>– Education and training</li> <li>– Insurance and public incentive schemes</li> </ul> </li> </ul>	4.7
Post-crash response	<ul style="list-style-type: none"> <li>• Rescue and first aid requirements</li> </ul>	4.8

## 4.1 Increasing usage: the combined approach

Once seat-belts have been installed in a vehicle, the next objective is to ensure that the vehicle occupants use them.

Improving seat-belt and child restraint use calls for a combined approach involving a range of sectors and disciplines (see Figure 4.2). The most powerful intervention is enforcement but to be effective it needs to be implemented after the public have been informed about seat-belts and the law.

Education, training and publicity should be used to ensure that there is sufficient public and political acceptance of the law and proposed enforcement. It should also be recognized that education and publicity without enforcement will only have a limited effect; for example, publicity used in the United Kingdom between 1970 and 1982 raised seat-belt wearing rates to 40%, but no higher (1). The most effective road safety programmes have been those that achieve a change in behaviour. It is of course also important to increase awareness and improve attitudes, but lives are actually saved when the desired behaviour patterns are adopted (2).

There are also other voluntary measures, such as employer regulation and incentive schemes and insurance and public incentive schemes, that can have an impact. These are not under the direct control of governments but they should be encouraged under a partnership approach to road safety.

### NOTE

#### Adopting an integrated programme of interventions

Overall an integrated programme of interventions should be adopted, with more emphasis being placed on voluntary methods at the start of multisectoral programmes followed by a progressive reliance on enforcement to reach high levels of compliance.

**Figure 4.2** The combined approach to increasing seat-belt usage

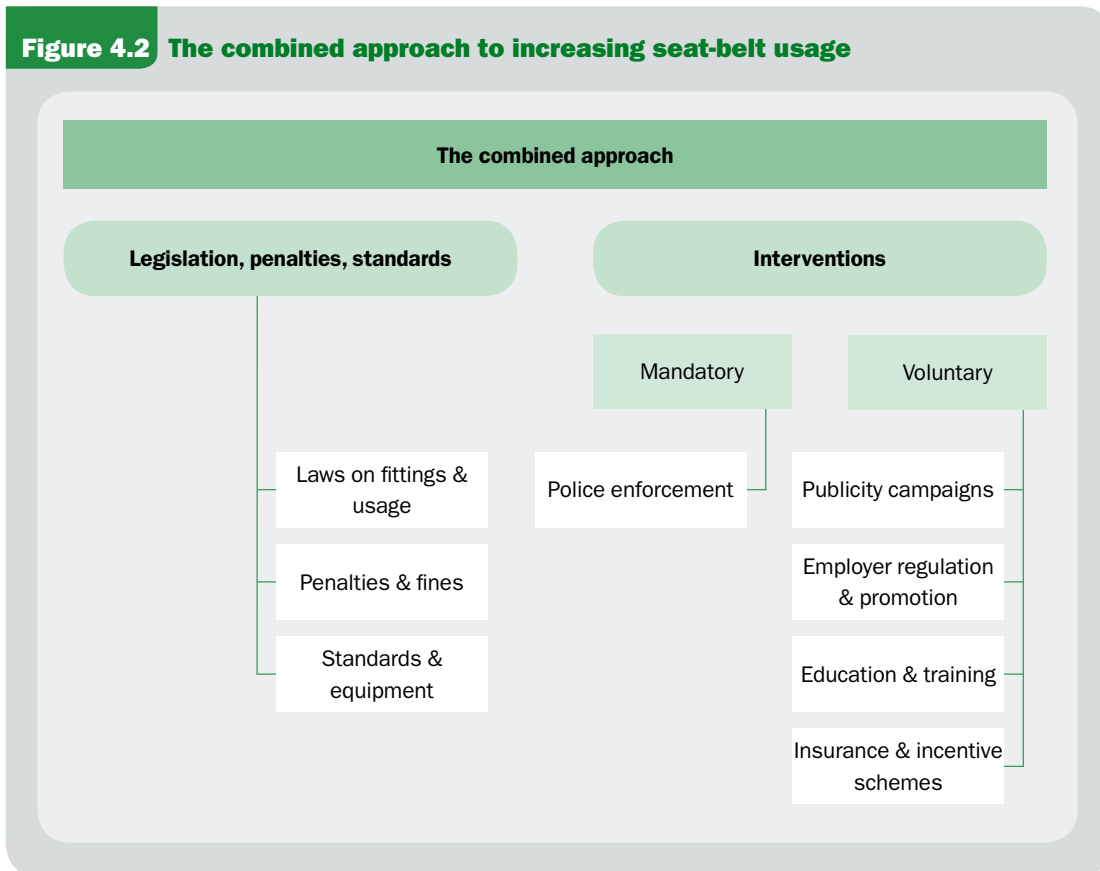

## 4.2 Legislation and penalties

The overall objective of a law is to make seat-belt use universal. This can be achieved by targeted and appropriate legislation on seat-belt fitting and wearing that is consistently enforced and well understood by the public. All three components are needed for success but clearly the first task is to develop and implement appropriate legislation.

The process of developing a law, though, will also help with other activities, such as the practical issues around enforcing the law. In addition, the process should strengthen the public consensus on the need for a seat-belt law.

**BOX 4.1: Key seat-belt legislation**

In the case of seat-belts, legislation needs to deal with the following three key issues:

- seat-belt fitting by vehicle type and inspection
- seat-belt wearing by vehicle type, passenger location, children
- penalties for non-compliance.

**4.2.1 Developing seat-belt fitting and usage laws**

In most cases, seat-belt fitting and wearing laws will involve adding a clause to a law already in existence, such as a road traffic or motor vehicle act. Sometimes, though, a completely new piece of legislation will be necessary.

The assessment of the current legislative situation (Module 2) will have identified the gaps and weakness in the system and the priority improvements required. These improvements are likely to include:

- drafting and enacting new legislation;
- expanding the scope of an existing law, for example to include additional vehicle occupant groups such as rear seat occupants;
- more clearly defining the actions required under the existing law and those responsible;
- increasing the penalties for non-compliance;
- increasing enforcement powers.

To help with the assessment process and with the development of legislation some examples from a number of countries of legislation on seat-belt fitting, adult seat-belt use, and child restraint use have been provided in Boxes 4.2 and 4.3. Appendix 3 provides an example seat-belt law.

**BOX 4.2: Example extracts of laws on seat-belt fitting****INDIA****Text:**

33a/125: Safety belt collapsible steering column, autodipper and padded dash boards:

(1) One year from the date of commencement of the Central Motor Vehicles (Amendment) Rules, 1993, the manufacturer of every motor vehicle other than motor cycles and three-wheelers of engine capacity not exceeding 500 cc shall equip every such vehicle with a seat-belt for the driver and for the person occupying the front seat.

34/1-A: The manufacturer of every motor vehicle of M-1 category shall equip every motor vehicle with a seat-belt for a person occupying the front facing rear seat:

Provided that the specifications of Safety Belt Assemblies and Safety Belt Anchorages in motor vehicles shall conform to AIS 005–2000 and AIS

015–2000 specifications, respectively, as may be amended from time to time, till such time as corresponding Bureau of Indian Standards specifications are notified;

Provided further that on and after 1st October, 2002, the specification of Safety Belt Assemblies and Safety Belt Anchorages in motor vehicles shall conform to AIS 005–2000 and AIS 015–2000 specifications, respectively.

37/125-A: Safety belt, etc., for construction equipment vehicles:

One year from the date of commencement of the Central Motor Vehicles (Amendment) Rules, 2000, the manufacturer of every construction equipment vehicle other than an agriculture tractor shall equip every such vehicle with a seat-belt for the driver and for the person occupying the front seat, and with a rear view mirror.

*Source: Central Motor Vehicles Rules, 1989, as amended by Central Motor Vehicles (First Amendment) Rules, 2003.*

**KENYA****Text:**

No motor vehicle shall be used or driven on a road unless it is fitted with seat-belts in the following manner:

(1) A seat-belt per seating position in a motor vehicle, and if seating accommodation is provided for more than two persons abreast whether by a continuous

seat known as a “bench seat” or by separate seats, the seat-belts for the persons other than those seated next to the body of the vehicle may consist only of a lap strap position of the seat.

(2) The owner of any motor vehicles used or driven on a road contrary to paragraph (1) shall be guilty of an offence and liable to a fine of one thousand shillings for every seat that is not fitted or, if fitted, is not of the proper standard or specification.

*Source: Laws of Kenya: The Traffic Act, Chapter 403, Section 119, Rule 22A (1) – Seat-belts.*

**BOX 4.3: Example extracts of laws on wearing seat-belts****AUSTRALIA****Text:**

Rule 264: Wearing of seatbelts by drivers

(1) The driver of a motor vehicle that is moving, or is stationary but not parked, must comply with this rule if the driver's seating position is fitted with a seatbelt.

(2) The driver must wear the seatbelt properly adjusted and fastened unless the driver is:

- (a) reversing the vehicle; or
- (b) exempt from wearing a seatbelt under rule 267.

Rule 265: Wearing of seatbelts by passengers 16 years old, or older

(1) A passenger in or on a motor vehicle that is moving, or is stationary but not parked, must comply with this rule if the passenger is 16 years old, or older.

(2) The passenger must occupy a seating position fitted with a seatbelt if:

(a) there is a seating position fitted with a seatbelt that is not already occupied by someone else who is not exempt from wearing a seatbelt; and

(b) the passenger is not exempt from wearing a seatbelt under rule 267.

(3) If the passenger occupies a seating position fitted with a seatbelt, the passenger must wear the seatbelt properly adjusted and fastened unless the passenger is exempt from wearing a seatbelt under rule 267.

(4) If the motor vehicle has 2 or more rows of seats, the passenger must not sit in the front row of seats unless:

(a) the passenger is occupying a seating position fitted with a seatbelt; or

(b) there is not a seating position available for the passenger in another row of seats; or

(c) the passenger is permitted to sit in the front row of seats under another law of this jurisdiction.

*Source: Australian Road Rules 1999; Part 16, Rules for persons travelling in or on vehicles.*

**KENYA****Text:**

(3) No person shall be in a motor vehicle which is in motion on a road and occupy a seat in a vehicle in respect of which a seat-belt is fitted in accordance with this rule without wearing the seat-belt.

(5) It shall be the responsibility of the conductor of a public service vehicle, and where there is no conductor, the driver of that vehicle, to keep the seat-belt in a clean, dry and generally wearable condition.

*Source: Laws of Kenya: The Traffic Act, Chapter 403, Section 119, Rule 22A (1) – Seat-belts.*

**VIET NAM****Text:**

If motor vehicles are equipped with seat-belts, the driver and the occupant of the front seat in the vehicle shall fasten the seat-belts.

*Source: Article 9 – General provisions; Chapter II – Rules for road traffic; Road Traffic Safety Law No. 26/2001/QH10, passed by the National Assembly in Session 9, 10th Congress, 22 May to 29 June 2001.*

## 4.2.2 Identifying legal responsibilities

Legislation should clearly identify who is responsible for complying with the law:

- For the fitting of seat-belts this is usually the manufacturer and sometimes the vehicle owner (see Box 4.2).
- For children it is strongly recommended that the adult driver is made responsible for the appropriate restraining of all children within the vehicle.
- For public service vehicles it is usually adult passengers who are responsible. The driver or the conductor can also be made responsible for keeping the seat-belt clean, as in the Kenyan example in Box 4.3.

## 4.2.3 Exemptions

Stakeholders should consider justifications for exemptions to the law and clearly state which vehicle occupants and under what circumstances may be exempt from wearing a seat-belt. This area of legislation is complex and widespread exemptions under the law are not advisable as they could undermine the effectiveness of a seat-belt use programme. Also, enforcement may be more time consuming and more difficult if there are differences in where the law applies, or if there are people who are exempt from the law.

Bearing this caution in mind it may still be desirable to allow certain well-defined exemptions (see Box 4.4), such as:

- **Emergency services.** On emergency response, or for other specialist reasons; this should not be a routine exemption, i.e. for every journey.
- **Types of vehicle.** Stakeholders may wish to consider exemptions for drivers of commercial passenger-carrying vehicles, such as taxis, if this is considered justifiable.
- **Health reasons.** Persons holding a valid certificate signed by a medical practitioner to the effect that it is inadvisable on medical grounds for them to wear a seat-belt, e.g. following major heart surgery. Note that pregnant women should not be exempt from the seat-belt law but they should only wear a three-point lap and diagonal seat-belt, not a lap belt on its own. They should also be given clear advice on the safe way to wear the seat-belt (Figure 4.3).



**BOX 4.4: Example extract of law on exemptions****UNITED KINGDOM****Text:**

You must use a seat-belt in cars, vans and other goods vehicles if one is fitted. Adults, and children aged 14 years and over, must use a seat-belt where

fitted, when seated in minibuses, buses and coaches. Exemptions are allowed for the holders of medical exemption certificates and those making deliveries or collections in goods vehicles when travelling less than 50 metres (approx 162 feet).

*Source: Laws RTA 1988 sections 14 and 15, MV(WSB)R, MV(WSBCFS)R & MV(WSB)(A)R & (MV)(WSBCFS)(A)R.*

**Figure 4.3** Three-point lap and diagonal seat-belts essential for pregnant mothers



“Mother and unborn child are both safer in a collision if a lap and diagonal seat-belt is worn correctly.”

Royal Society for the Prevention of Accidents (RoSPA)

When considering exemptions it should not be forgotten that with the exception of a medical condition whereby the use of a seat-belt may further endanger the life of an individual, seat-belts do save lives. Also, when making exemptions, legislation should ensure that there are clear definitions that prevent ambiguities.

#### 4.2.4 Penalties for non-compliance

Clearly the penalty for non-compliance must be perceived as sufficiently serious to deter would-be law-breakers. The penalties should be set in line with penalties for other traffic law violations and they can be linked to a penalty points system that

leads to more serious penalties, such as the cancellation of the driving licence when accumulated points pass predetermined limits. Similarly the law could specify a more serious penalty for repeat offenders. In general it is simpler to specify a fixed fine for non-compliance with wearing laws to make sure that the enforcement and administration procedures are straightforward.



#### CASE STUDY: **France: enforcement of seat-belt law**

In France, increased enforcement led to the number of fines for non-use of seat-belts rising by 15% from 2002 to 2003, and in July 2003 there was also an increase from one to three penalty points added to a driver's licence for not wearing a seat-belt. As a result of these measures, the use of seat-belts by front

seat occupants went up to 90% in urban areas and to 97% outside urban areas. Wearing rates continued to rise and by 2006 the urban rate was 94%, and outside urban areas 98% of front seat occupants were wearing seat-belts. (3).

Consultation with stakeholders is crucial when developing the law and setting penalties. When implementing and starting enforcement of a new or revised law the legal arrangements could allow for a preparatory period when warning notices are given to offenders instead of fines. These notices would usually inform motorists that there had been a change in the law and that in future a penalty will be imposed for breaking it. Alternatives to fines can also be specified, such as the requirement to attend accredited driver training courses. Box 4.5 shows some examples of seat-belt legislation specifying the penalties applicable to drivers in non-compliance.

**BOX 4.5: Example extracts of laws on penalties****KENYA****Text:**

(2) The owner of any motor vehicles used or driven on a road contrary to paragraph (1) shall be guilty of an offence and liable to a fine of one thousand

shillings for every seat that is not fitted or, if fitted, is not of the proper standard or specification.

(4) A person who does not wear a seat-belt as required under paragraph (3) shall be guilty of an offence and liable to a fine of five hundred shillings.

*Source:* Laws of Kenya: The Traffic Act, Chapter 403, Section 119, Rule 22A (1) – Seat-belts.

**VIET NAM****Text:**

Punishment in the forms of warning or monetary fine from VND 10,000 to VND 30,000 shall be applied to the driver and the occupant of the front seat in the vehicle equipped with seat-belts who do not fasten the seat-belts while the vehicle is running.

*Source:* Article 9 – Fines applicable to drivers of automobiles and vehicles having similar structures which violate road traffic rules; Chapter II – Administrative fines applicable to violations of road traffic rules; Decree No.15/2003/ND-CP issued by the Government prescribing administrative fines applicable to violations of road traffic rules.

**4.2.5 Developing and implementing legislation**

The requirements for ensuring that the legislation is enacted and that it will be vigorously enforced are:

- strong support from the highest levels of government, sending a clear message to society that seat-belts and traffic safety are vital national issues;
- sufficient public support to ensure that enforcement of the law will be accepted by the majority;
- sufficient commitment from the enforcement and communication agencies to ensure their full participation.

The timescale and phasing of the seat-belt programme will depend on how easy or difficult it is to meet these requirements (see next section).

The following questions should be considered when trying to meet these requirements and appropriate actions taken:

- Which agencies will be most effective and influential in implementing legislation?
- Are the capabilities of the agencies adequately addressed in the legislation?
- Is the proposed legislation worded in an appropriate way, so as to gain support?
- What are the proposed penalties for motorists disobeying the law? Are these penalties appropriate and are they likely to be effective?
- Has there been sufficient consultation with stakeholders, politicians and the public?

The advocacy activities of the working group will be essential in promoting and gaining approval for the legislation. Members of the group who are government officials, policy-makers, or injury prevention specialists will have the greatest influence in convincing others of the need for a law.

Adequate public awareness must be ensured in order to optimize the success of the law and consultation and information programmes must be integrated when the law is being developed. The Costa Rica case study gives an example of promotion of seat-belt wearing before legislation was passed and enforced.



### CASE STUDY: **Costa Rica: seat-belt legislation, awareness raising and enforcement**

In 2003–2005 the Government of Costa Rica led a successful programme to reintroduce a seat-belt law. The country's previous seat-belt law had been abolished some years earlier after it was ruled to contravene constitutional freedoms, and the subsequent drop in seat-belt use had been blamed by the government for a rise in road casualties.

To build public support for a new seat-belt law, the government assembled a coalition including the Road Safety Council, the traffic police, the National Insurance Institute and the Costa Rican Automobile Club to promote an awareness campaign about the individual and societal benefits of using a seat-belt. This campaign was intended to both build support for proposed new legislation and prepare the population for future police enforcement. The campaign was entitled “Por Amor Use el Cinturón” (For love use your seat-belt). Publicity materials, including television and radio adverts, billboards and newspaper adverts,



Automobile Club of Costa Rica (both photos)

were complemented by a media relations campaign promoting seat-belt use. The traffic police distributed advice leaflets to drivers encouraging them and their passengers to use their seat-belts.

Legislation was passed in April 2005 and by May, after a two-week grace period to allow for further awareness raising of the new law amongst motorists, the police began enforcement, issuing fines for non-compliance. Surveys conducted before the legislative and publicity campaign and then again after the introduction of the new law showed driver seat-belt use during the period rising from 24% to 82% (4).



### CASE STUDY: **Bahamas: need for adequate consultation**

The need to consult before implementation of a seat-belt law is illustrated by the case of the Bahamas, where implementation of the mandatory seat-belt law was suspended for four years after it was passed due to concern about the level of penalties and lack

of exemptions. Amendments have been passed to address these issues and to improve the regulations concerning children in accordance with international recommendations (5).

#### 4.2.6 Phasing implementation

In practice many countries have phased in both fitting and wearing seat-belt legislation. For fitting laws this has happened largely because the initial priority relating to reducing road traffic crash fatalities and injuries was to protect car occupants. These laws were then extended to buses and trucks.

Wearing laws have also often been phased in by type of occupant, with front seat wearing being made mandatory before rear seat wearing and child restraints.

Campaign planners believe that the best approach is to see full vehicle occupant legislation (covering front, rear and child vehicle occupants) introduced in a single phase. This sends a consistent message that seat-belts save lives and injuries whatever the location of the occupant and avoids the possible misperception caused by tiered legislation implying that it is not as necessary to wear a seat-belt in the rear as in the front. However, historically most governments have considered this too much to ask of the driving public immediately and have adopted a phased approach. A typical example of phased legislation is shown in the case study from Australia.



### CASE STUDY: **History of seat-belt legislation, Australia**

In 1959, the Senate of the Commonwealth Parliament in Australia established a Select Committee whose primary aim was to investigate the most effective ways of promoting road safety in the country. The Committee (1960) recommended that “the motor trade should install seat-belts of an approved standard in all motor vehicles. Road safety authorities should give publicity to the advantages of wearing seat-belts.”

Australian Standard E35 (Safety Belts) was introduced in 1961 and was very similar to that used in the United Kingdom (BS 3254). A standard with specifications for anchorages (D11) was produced in 1967. To ensure that seat-belts conformed to this, the Standards Association of Australia (SAA) registered a certification mark that would be used

by manufacturers who were approved by the SAA, enabling consumers to identify seat-belts that were manufactured to the national standard.

Starting in 1962, the Australian Road Safety Council produced a monthly journal attempting to generate awareness of seat-belts and their benefits, and reported on work undertaken to try and achieve this. The journal, *Report*, continued for over a decade.

After a recommendation by the Victorian Joint Select Committee for Road Safety (1969), legislation was introduced (1970) making it mandatory for vehicle occupants to wear seat-belts. Soon after, similar legislation was introduced in New South Wales (1971). By 1972, seat-belt wearing legislation applied to the whole of the country.

It is important that an appropriate time frame be developed for enacting the law. The time frame from implementation of the law to full enforcement and penalty for non-compliance can be anything from a couple of months to several years. This will depend on the situation in the country, and must be articulated in the overall action plan.

#### **4.2.7 Section summary: checklist for seat-belt legislation**

A checklist for seat-belt legislation might be as follows:

- Aim to develop seat-belt and child restraint laws to make restraint usage universal. Seat-belts and child restraints reduce death and injury severity in road crashes.
- Aim to develop and enact legislation that deals with the three main issues: seat-belt fitting by vehicle type and inspection; seat-belt wearing by vehicle type, passenger location, children; and penalties for non-compliance. Include legislation prohibiting carriage of children in front seats unless placed in approved child restraints, with airbags switched off.
- Use the gaps and weaknesses identified in the situation assessment to guide the development of a seat-belt usage programme and action plan.
- Consult with stakeholders when developing laws and setting penalties.
- Consider phasing in fitting and wearing seat-belt legislation, with front seat wearing being made mandatory before rear seat wearing and child restraint. However, introducing full vehicle occupant legislation is believed to be the best approach as it sends a consistent message and avoids possible misperceptions.

- Requirements for ensuring legislation is enacted and will be enforced include strong political support, sufficient public support, sufficient commitment from the traffic police and advocacy through communications agencies.
- Consider the level of severity of penalties for non-compliance. Penalties must be perceived as sufficiently serious to deter would-be law-breakers and consistent with penalties for other traffic law violations.
- Consider carefully any justifications for exemptions to seat-belt laws. Widespread exemptions are not advisable as they could undermine the effectiveness of a seat-belt programme.

### **4.3 Seat-belt standards and equipment**

This section is for practitioners and campaigners who are responsible for the overall design and implementation of a seat-belt programme. It therefore aims to introduce seat-belt standards from a general point of view. A more detailed and technical examination of seat-belt standards should be undertaken by technical specialists.

The information provided in this section of the manual refers to the manufacturing and fitting of seat-belts. It aims to give guidance and recommendations on the use of legislation and standards to increase the safety of vehicle occupants. The key to achieving success is consultation and partnership with vehicle manufacturers. If countries can ensure that vehicles sold in their country have seat-belts installed as standard, manufactured to the specified regulations set out within legislation, then stakeholders can start to work towards increasing wearing rates.

Stakeholders should note that ease of use and comfort will inevitably affect wearing levels. Therefore, recommendations are based on types that have proved to be effective in providing satisfactory support in a crash and that minimize inconvenience to the vehicle occupant when fastening and wearing.

This section provides information on:

- adopting a standard or regulation (4.3.1)
- types of standards or regulations and their content (4.3.2)
- Testing and certification (4.3.3)
- vehicle inspection and seat-belt maintenance (4.3.4)
- retrospective fitting (4.3.5)
- in-vehicle reminder systems (4.3.6).

### 4.3.1 Adopting a standard or regulation

One of the objectives of a seat-belt programme might be to raise the quality of the seat-belts being used. This is best achieved by ensuring that all seat-belts meet a recognized safety standard – one that has been demonstrated as being effective in reducing injuries.

Standards mostly include technical requirement specifications and test methods regarding the construction and installation of the different seat-belt types and their components.

A few questions to ask when developing, adopting or revising a seat-belt standard include:

- Does a national standard exist?
- Does the national standard meet international standards?
- Are vehicle standards enforced and are they adhered to by vehicle manufacturers and distributors?
- Are consumers aware of the standard?

If the situation assessment (Module 2) reveals shortcomings in the fitting of seat-belts and their components then a specialist committee should be established as part of the working group (Module 3 and Figure 3.1) to make decisions about adopting or revising standards and strengthening control mechanisms for improving compliance. This committee should include appropriate technical experts from key government agencies, standards specialists and representatives from vehicle and component manufacturers.

Consultation with vehicle manufacturers and distributors is crucial to ensure that a standard is not so stringent as to restrict production and availability.

Ideally stakeholders should harmonize with one specific standard to ensure consistency at a global level. It is recommended that countries base standards on the United Nations Economic Committee for Europe (UNECE) regulations. The appropriate UNECE body to establish uniform prescriptions regarding new motor vehicles and motor vehicle equipment is the World Forum for Harmonization of Vehicle Regulations (WP29). More details on these regulations are provided in section 4.3.2.



**NOTE****UNECE regulations**

The UNECE regulations under the 1958 Agreement (6) cover the following:

- (a) wheeled vehicles, equipment or parts concerned;
- (b) technical requirements, which if necessary may include alternatives;
- (c) test methods by which any performance requirements are to be demonstrated;
- (d) conditions for granting type approval and their reciprocal recognition, including any approval markings and conditions for ensuring conformity of production;
- (e) the date(s) on which the regulation enters into force.

Each Contracting Party to the 1958 Agreement (see note on UNECE regulations) can decide if it wants to apply a UNECE regulation (its application is therefore optional). A Contracting Party that decides to mandate a regulation on its territory must do so by transposing the regulation to its national or regional legislation.

Countries can make additions to these standards; this may be necessary to meet local environmental conditions (see note on environmental conditions). In addition, countries can consider harmonizing their standards and regulations in stages. India, for example, has adopted a three-stage process (see case study from India).

**NOTE****Standards and environmental conditions**

When adopting standards, stakeholders should assess the effects of their natural environment on the seat-belt components. For instance, prolonged periods of ultraviolet (UV) light from the sun can reduce the lifespan of a seat-belt unless treated. The heat from the sun can also distort some types of materials. Australia has adopted the UNECE regulations, but added to them to ensure suitability within their environment.

**Table 4.2 Contents of UNECE Regulations 14, 16 and 44**

Contents of regulations	Reg. 14	Reg. 16	Reg. 44
	Anchorage	Installation	Child restraints
<i>Application for approval:</i>			
The technical details required within an application by the manufacturer, also highlighting measures to control conformity	4	4	4
<i>Approval:</i>			
Labels stating approval, granted by a specified authority	4	4	4
<i>Markings:</i>			
Indicates the obligation on the manufacturer to provide details about the product		4	4
<i>Specifications:</i>			
Specified requirements of the product	4	4	4
<i>Testing:</i>			
Highlights the type of tests required to be undertaken for individual components and products, specifying the minimum and maximum results of conformity	4	4	4
<i>Inspection after testing:</i>			
Evaluation and documentation of testing results	4	4	4
<i>Modifications:</i>			
Manufacturers obligation to inform the approval authority and document any modifications to a product that have been approved	4	4	4
<i>Installation:</i>			
Outlining the requirements of installation dependent on the seat type		4	
<i>Conformity of production:</i>			
Identifies the obligation on the manufacturer to implement control measures to ensure conformity	4	4	4
<i>Penalties for non-conformity:</i>			
Outlines the penalties enforced for non-compliance	4	4	4
<i>Operating instructions:</i>			
Standard instructions to be provided by the manufacturer to the product user	4	4	4
<i>Production discontinued:</i>			
The obligations on the manufacturer to inform the approval authority that a product has ceased to be manufactured	4	4	4
<i>Transitional provisions:</i>			
Periods of notice given to manufacturers to comply with amendments to regulations	4	4	4



### CASE STUDY: **Harmonization of standards with UNECE regulations, India**

India has established a harmonization process for four-wheeled (or three-wheeled if the weight exceeds 1 tonne) passenger vehicles. Regulations AIS 016 (seat-belts) and AIS 015 (anchorage) have been designed to harmonize with UNECE regulations. As

such, India has introduced legislation to ensure that vehicles sold within the country meet the requirements of these standards using a three-tiered (phased) approach with targets set for 2003, 2005 and completion in 2010.

#### 4.3.2 Types of standards or regulations and their content

UNECE has developed and regularly updates three key regulations under the 1958 Agreement: 14, 16 and 44 (see Table 4.2), on the design and installation of seat-belts, their anchorages and child restraints for its Member States (7–9).

There are currently 58 countries from various regions of the world that have acceded to the 1958 Agreement, including countries in Asia and Africa, for example Malaysia, the Republic of Korea, Thailand and Tunisia.

For more extensive information on the regulations see the UNECE web site: <http://www.unece.org/trans/main/wp29/wp29regs.html>.

Some examples of standards for seat-belt components are shown in Table 4.3.

**Table 4.3** Seat-belt components and example quality standards

Component	Example UNECE standards
<i>Buckles</i>	Easy to engage and disengage and be designed to minimize injury to the user
Section 6.2.2 of UNECE Regulation 16	Single-handed operation is possible for front seat occupants Release buttons are red (easy to locate) Maximum and minimum forces for operation of the release button
<i>Adjustment system and pretensioners</i>	Seat-belts must not be slack when worn to be effective
Section 6.2.6 of UNECE Regulation 16	Retracting seat-belts with automatic locking systems are much more comfortable for users Load limiters allow controlled release of the webbing to minimize forces on the user
<i>Anchorage</i>	The standard prescribes the appropriate structural position of the anchorage points and the type of bolts used for fastening
Annexe 3 of UNECE Regulation 14	Lap straps must be positioned to prevent wearers from slipping under the belt and shoulder anchorage should be above shoulder height to avoid compressing the spine in a crash

### 4.3.3 Testing and certification

The testing and certification process is employed to enforce the seat-belt regulations. It is recommended that countries introduce a type approval system for testing and certifying seat-belts and that an independent centre with well-trained inspectors is established to carry out the tests.

This approach requires manufacturers to submit a sample product to the designated approval department for independent testing and authorization using the tests specified in the regulations.

Typical tests required for seat-belt certification are shown in box 4.6.

#### BOX 4.6: Performance tests for seat-belts

##### Dynamic test

The test is performed on seat-belt assemblies to verify the minimum displacement of the manikin and that no part of the assembly, affecting the restraint of the occupant, would break, release or unlock (paragraph 6.4.1. of UNECE Regulation 16).

##### Dynamic strength test

The dynamic strength test uses a test dummy on a sled, restrained by the seat-belt under test attached to standard anchorages or those prescribed for use (paragraph 7.7 of UNECE Regulation 16).

The dynamic test may be performed after multiple operations of the mechanisms (e.g. buckles, adjusters, retractors) to provide a control on the durability of the system (paragraph 7.5 of UNECE Regulation 16).

##### Abrasion test

The seat-belt webbing should be subject to an abrasion test and, if thought appropriate, a sunlight degradation test (paragraph 6.4.2.1 of UNECE Regulation 16).

##### Durability tests

Other mechanical parts of the seat-belt should be subject to durability testing, appropriate for the conditions under which they are expected to operate. This could include, for example, high or low temperatures or a sandy environment or high humidity environment, as these factors are known to affect seat-belt performance (section 7 of UNECE Regulation 16).

If testing identifies non-compliance, the product tested would not be type approved, or if the test is performed to verify the conformity of production, the product should be removed from production and sale until such time as it has been modified to comply with the requirements outlined by the regulations. This would subsequently result in a recall of that product if sales have been made (refer to section 10 of UNECE Regulations 14 and 16, and section 12 of UNECE Regulation 44).

Seat-belts that are approved under the regulations must have a label attached with an international approval mark showing year of manufacture, approval number for the seat-belt type and manufacturer and the manufacturer's serial number.

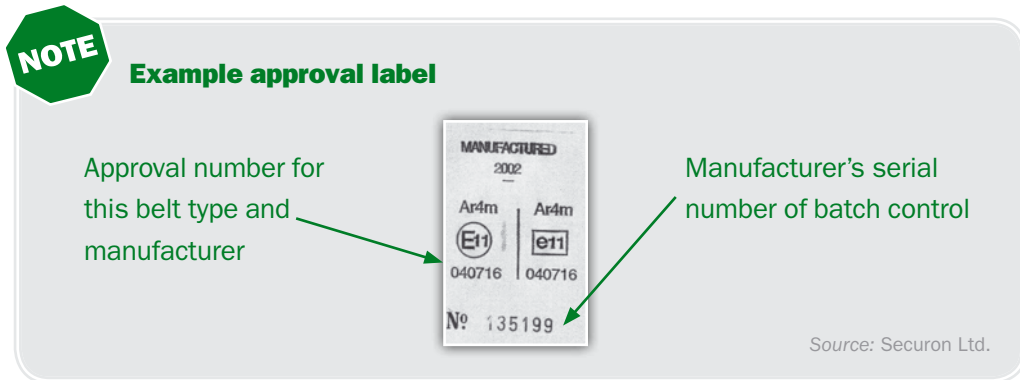

#### 4.3.4 Vehicle inspection and seat-belt maintenance

It is important that the condition of seat-belts is checked regularly and that they are maintained in good working order. Countries that have mandatory vehicle inspection systems for vehicles in use should include checks of the seat-belts, retractors and anchorage points for corrosion, damage and excessive wear and tear that may reduce the capability of the whole system. To ensure effective checking it is important that the vehicle testing manual includes the testing procedures for seat-belts and that the inspectors are trained to carry out these procedures. An example inspection procedure from the United Kingdom is shown in Appendix 4.

In addition vehicle owners should be informed of the need to check and maintain the seat-belts. Seat-belts that have been deployed in serious crashes or that have been damaged should be replaced. Even minor damage to seat-belt webbing or components can significantly reduce their effectiveness. For example, a small 2–3 millimetre (mm) cut in the webbing can reduce the effectiveness of the seat-belt by up to 40% in a static test (Figure 4.4).

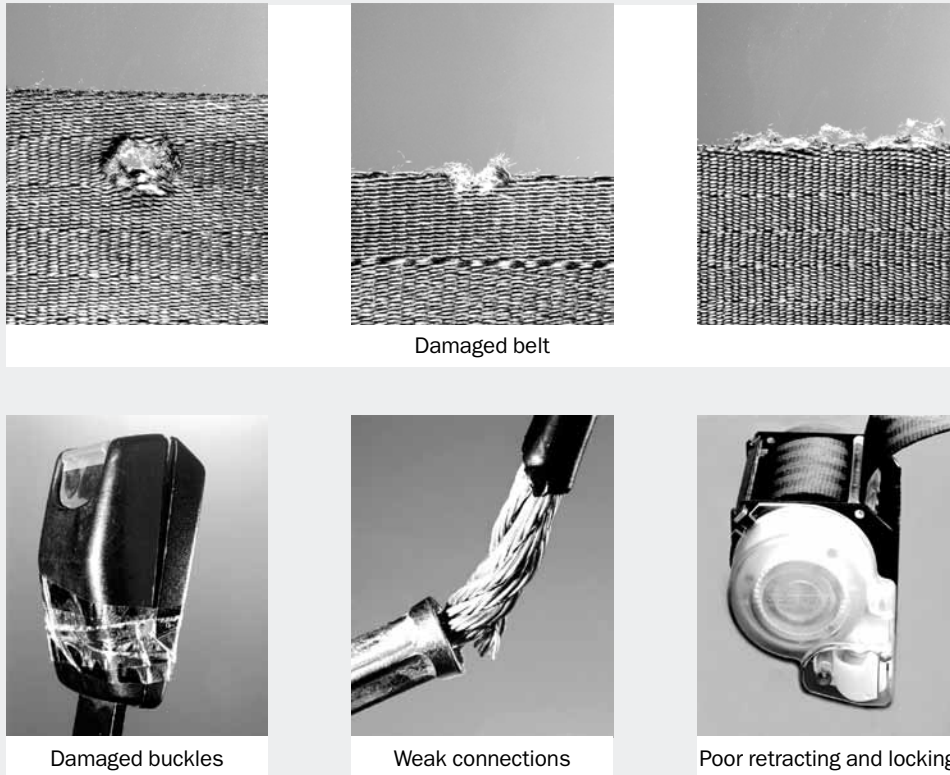
**Figure 4.4 Possible seat-belt damage**

Source: Securon Ltd.

#### 4.3.5 Retrospective fitting

In countries in which a significant proportion of the vehicle fleet are not fitted with seat-belts, or only have front seat-belts fitted as standard, due to their date of manufacture, it may be necessary to consider a requirement for retrospective fitting of seat-belts (i.e. fitting of seat-belts after the point of manufacture and sale). Seat-belts will not be effective unless they are installed in accordance with an appropriate standard (see box 4.7). When choosing the type of seat-belt, the level of protection must be considered against the practicality of fitting and the cost of the conversion.

**BOX 4.7: Standards for retrospective fitting of seat-belts**

Where effective and controlled retrospective fitting can be achieved, the following recommendations have been made in the Australian and New Zealand standard AS/NZS 2596 (10):

- The belt should be anchored to a substantial part of the metal body or frame of the vehicle.
- Anchors for lap belts and lap sections of other assemblies should be at least 380 mm apart, where practicable.
- The shoulder anchor point of lap and diagonal belts should be located at or about shoulder height so that, for all sizes of wearer, the torso strap passes across the chest like a sash and over the shoulder to the anchor. The height of this point in relation to shoulder height depends partly upon the distance between shoulder and anchor. For tall wearers, the torso strap may of necessity slope downwards from shoulder to anchor; 15 degrees is recommended as the maximum angle below the horizontal. Torso straps of harness belts should similarly be anchored at or about shoulder height.
- Each anchor point in the vehicle should be capable of withstanding a force of at least 12.5 kilonewtons (kN) without fracture. Unless the vehicle has inbuilt anchorages, the use of reinforcing plates or other devices is essential to prevent the belt anchors pulling out of the vehicle body or frame. Those provided with the assembly should be used.
- Where anchor fittings from two adjacent assemblies are to be connected to the same anchor point in the vehicle, the anchor should be capable of carrying the combined force of the two assemblies, i.e. 25 kN.
- Vehicle seat structures are usually inadequate for carrying seat-belt loadings and should not be used as anchors unless the vehicle manufacturer has provided inbuilt seat-belt anchors in the seat.

**CASE STUDY: Malaysia: retrofitting of rear seat-belts**

Rear seat-belts will be made compulsory in Malaysia for all car occupants starting on 1 January 2009. However, vehicles produced before 1 January 1995 will be exempted, as many were not equipped with rear seat-belts or anchorage points. Vehicles produced after this date that do not have anchorage

points will also be exempt. Among this older group of private vehicles (produced post-1995), about 10% are being retrofitted with seat-belts free of charge through a smart partnership involving the Road Safety Department and car manufacturers. Vehicle owners have been given three years to retrofit the seat-belts.

The minimum legal requirement for seat-belts in coaches should be to fit a two-point lap belt. A three-point lap and diagonal seat-belt does offer greater protection but it may not be feasible to retrofit these types of seat-belts on older coaches. A two-point lap belt will assist in restraining the occupants within their seats and significantly reduce the likelihood of death or injury.



### CASE STUDY: **Cost-benefits of retrofitting seat-belts in buses, United Kingdom**

To illustrate the benefits of seat-belt compliance, in 1994 the United Kingdom's Department for Transport conducted an analysis of the financial savings made through mandatory retrofitting and 90% usage of seat-belts in coaches, minibuses and

vans. Installation costs were compared to casualty costs. This highlighted a casualty saving of US\$ 5 250 000 in coach crashes alone (giving a net benefit of US\$ 1 725 000, taking into account installation costs) (11).

#### 4.3.6 In-vehicle reminder systems

Several devices have been developed in recent years to remind vehicle occupants to buckle up. Typically they comprise a flashing light on the dashboard and a loud warning tone, which can increase in intensity with higher speeds. Initially they operated only for the driver's seat but new systems can be applied to any seat.

In 2006 more than half the new cars sold in Europe were fitted with reminder systems to warn drivers that they have not buckled up their seat-belt. Safety experts suggest that the reminders will work with drivers and passengers who forget but they recognize that they are unlikely to affect hard-core non-wearers. Japan made reminder systems mandatory for the driver's seat in 2005. All countries should consider similar legislation and should not add additional taxes for these items or for seat-belts, for example by classifying them as luxury items.



### CASE STUDY: **In-car seat-belt reminders increase wearing levels, Sweden**

A Swedish study indicated that reminders giving audible and visual signals increased wearing levels from 77% to 88%, according to ambulance personnel reports from crash scenes. Wearing levels seemed to be virtually unchanged for systems that gave only visual signals (12).



### 4.3.7 Section summary: checklist for developing seat-belt standard or regulation

A checklist for developing a seat-belt standard or regulation might be as follows:

- Examine current seat-belt manufacturing and fitment standards and guidance.
- Determine whether an existing standard needs revision or a new standard has to be developed.
- Determine current levels of vehicles fitted with seat-belts.
- Determine current levels of vehicles with anchorage points only.
- Calculate the cost of retrospective installation for vehicles with anchorages only and establish realistic consumer costs.
- Lobby government and increase support to establish a working party to address the need for the introduction of technical standards for the manufacturing and fitting of seat-belts and child restraints.
- Establish a working party (which should include manufacturers and consumer groups) to identify the ability of the country or state to conduct regular vehicle inspections, outlining improvements to be made.
- Develop and agree an action programme with targets and realistic timescales.
- Develop and agree standards or regulations based on UNECE Regulations 14, 16 and 44.
- Lobby for legislation to be introduced that incorporates the appropriate changes and ensure that the standard is included in national legislation.
- Establish a procedure for testing and certification of seat-belts by a regulatory agency and for enforcement of the new standard or regulation.
- Agree a timescale for manufacturers and retailers to conform to new standards.
- Produce and disseminate information on the new standard to manufacturers, retailers and the public.
- If vehicle inspection is mandatory, establish a procedure for inspecting seat-belts and implement guidance and training for inspectors.
- Produce seat-belt inspection guidance for vehicle owners.
- Encourage private and public sector organizations to play an active role in promoting and controlling the use of seat-belts that meet international standards.
- Monitor and evaluate the effectiveness of the standards and regulations programme.

## 4.4 Increasing usage: enforcement

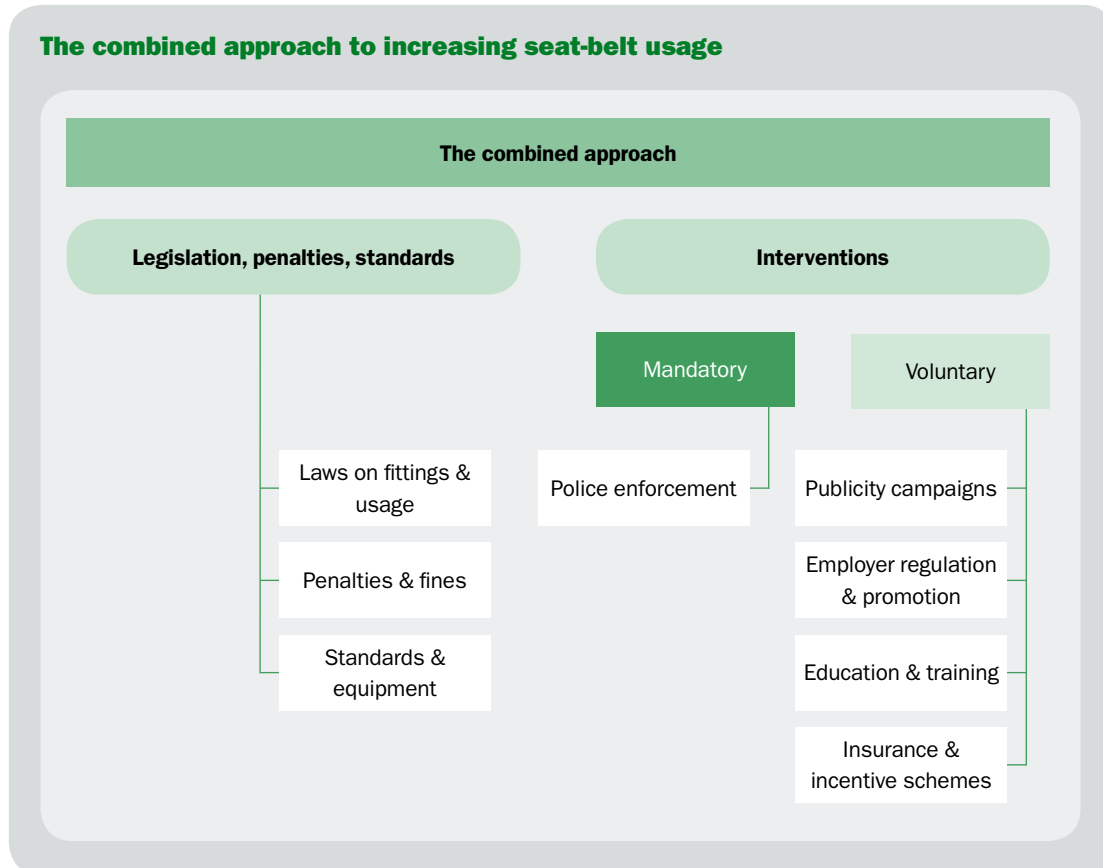

The most effective tool for increasing compliance is enforcement, especially when it is supported by voluntary measures, in particular targeted publicity and education campaigns. This section deals with enforcement.

### 4.4.1 Pre-requirements

Three essential requirements prior to starting the enforcement campaign are:

- **Lead by example.** Government and other agencies, particularly the transportation, health and police departments, should take the lead and make seat-belt use compulsory for their own staff under their contracts of employment, and they should be seen to wear them at all times.
- **Inform the public about enhanced enforcement.** Motorists should be informed in plenty of time about new laws, changes in enforcement and the penalties for non-compliance through appropriate media.
- **Raise public and political awareness and support** to a sufficient level to ensure that the enforcement campaign will be acceptable.

#### 4.4.2 Enforcement strategy

Strategic traffic law enforcement can and does make a difference if it follows good practice. For effective implementation of seat-belt laws:

- enforcement must provide a meaningful and deterrent threat to non-seat-belt wearing motor vehicle users;
- the perceived risk of apprehension and prosecution must be high.

The **objective** of a proactive seat-belt law enforcement intervention is to ensure that seat-belts are worn by all vehicle occupants on all roads at all times.

The **outcome** sought is an increase in seat-belt wearing, which will lead to a reduction in injuries, road trauma and deaths.

Apprehending offenders is a by-product of the intervention, not the main objective itself. As the intervention proves to be successful, apprehensions should decline and allow police to change the priorities of their strategy.

Enforcement should be “intelligence led”, which requires:

- Understanding which occupants are most at risk and the groups who are not using seat-belts through data collection and analysis. Police crash reports must include information about seat-belt usage at the time of the crash.
- Understanding community perceptions and political commitment regarding seat-belt wearing. Public pressure on politicians can lead to greater support for more intense enforcement of seat-belt laws. Political will is critical in ensuring a consistent and rigorous enforcement process.



George Institute

Moving from the introduction of a new law to its full enforcement can be a lengthy process depending on the position of the politicians and the public regarding the law. Compliance with the law should be built up in planned stages to ensure sufficient political and public support.

Enforcing a seat-belt law creates an extra burden on the police. It is useful in advance to examine the capacity of the police force, to explore how to integrate seat-belt enforcement into current policing activities, and to determine whether resources are available for possible additional recruits. In any case, traffic police will need training in the new law and how best to enforce it.

How well the police can cope will help decide whether to introduce a blanket enforcement of the law or to take a phased approach. Phased enforcement should target those areas where seat-belt wearing rates are known to be low and where casualty rates among vehicle occupants are high.

Police action after apprehending violators can also be phased. Typically when enforcement commences police can start by issuing warnings and explaining the new law and then after a time agreed in the legislation they can issue the appropriate fines. Increasing the severity of the fines can also help increase wearing levels but this will usually be implemented through the legislation process (see section 4.2.4).

However, it must be noted that phasing in legislation, and allowing certain exemptions from laws, are steps that themselves introduce a set of concerns with regards to enforcement. Enforcement may be more time consuming and more difficult if there are differences in where the law applies, or if there are people who are exempt from the law.

Senior police officers must take a lead in the initial planning and implementation of intervention strategies. A “champion” in the police field will ensure ownership within the enforcement community and assist in ensuring the sustainability of a national or statewide campaign on seat-belt wearing. Police commanders must appreciate the cost of enforcement compared with the cost of rescue operations, medical treatment and rehabilitation of the injured.

Training in effective strategic law enforcement may also be helpful in obtaining and maintaining the commitment of police officers to enforce the seat-belt laws.



## CASE STUDY: **Seat-belt campaign strategy, United States**

The first formal enforcement campaign (primary law) in the United States was conducted in Elmira, New York, in the 1980s. The approach used in this county was later used as a model for other campaigns across the country. Williams et al. (2000) (13) highlighted the success of this campaign, with front seat wearing rates increasing from 49% to 80%. However, the enforcement programme was not maintained, and wearing rates fell to 69%.

In 1997, the National Highway Traffic Safety Administration (NHTSA) initiated the Buckle Up America public health and safety campaign designed to increase seat-belt use nationwide. The campaign, now called Click It or Ticket, was built around a four-point strategy that is still the foundation of NHTSA campaigns (14). The rate of seat-belt use increased from 61% in 1996 to 82% in 2005.

### **Point 1: Enact strong legislation**

It is imperative to adopt primary enforcement seat-belt use laws and to close the gaps in child passenger safety laws in all states. Police officers should be able to write a citation whenever a seat-belt violation is observed, whether or not the driver has committed any other traffic infraction. Child passenger safety laws should cover all children up to age 16 years in every seating position.

### **Point 2: Build public–private partnerships at the local, state and federal levels**

The goal of increasing seat-belt use is too big for any one group or agency to accomplish alone. But

working together, the nation can achieve higher use through stronger laws, visible enforcement and public education and information. Partnerships or coalitions can set the tone in a community, workplace or organization, and the media can help spread the message that the proper use of seat-belts and child safety seats are imperative for maintaining the health and well-being of families and other community members.

### **Point 3: Conduct active, high-visibility enforcement**

Experience has shown that, after seat-belt use laws are passed, seat-belt use increases quickly. But without active and sustained high-visibility enforcement, it soon drops again. Seat-belt laws must be visibly enforced the way other traffic laws are (red light running, speeding, etc.). In addition to increasing seat-belt use and reducing crash injuries, high-visibility enforcement results in a measurable reduction in crime (one third of criminal apprehensions occur as part of traffic stops).

### **Point 4: Expand effective public education**

It is critical to educate the public about the benefits of seat-belt and child safety seat use. Public education may include a broad range of activities such as enforcement campaigns, promotional events and community-based initiatives. These activities are most effective when they are well planned and coordinated and use a simple message that is repeated many times in different ways.

### 4.4.3 Enforcement methods

Strategic law enforcement integrates four fundamental principles of policing in a multidimensional intervention (Table 4.4).

**Table 4.4** Four fundamental principles of law enforcement

Principle	Elaboration of principle
Increased visibility of enforcement	<p>This includes highly visible, publicly observable and strategically located checkpoints and roadblocks</p> <p>These must be varied in location, intensity and time of day or night. There should be many police officers in each working team</p> <p>Visibility includes signage about the enforcement activity, safety vests for police and adequate lighting at night</p>
Repetition of enforcement campaigns	<p>This indicates to motorists that the risks of being caught are high – anywhere, any time</p>
Strict and consistent enforcement	<p>After an initial public warning period, police enforcement should be strict, non-discriminatory, fair and consistent – not just short term, on highways or where police enforcement can be anticipated</p> <p>If there is no enforcement, there will be limited or no compliance</p>
Well-publicized enforcement	<p>To achieve maximum effectiveness, compliance-driven enforcement must be combined with coordinated education and publicity campaigns involving the engagement of government, local government, the mass media and other agencies</p> <p>Publicity campaigns should be conducted before, during and after policing activities with reinforced safety messages</p> <p>Safety brochures on correct seat-belt use may be handed out with a warning as an alternative to issuing a fine</p> <p>Education and instruction can include reminders of the benefits of seat-belt wearing and the constant promotion of safety messages</p>

As well as adopting these principles, the enforcement agencies, together with their collaborating partners, should agree **minimum annual targets** for levels of compliance based on benchmark surveys of seat-belt wearing. The enforcement strategy should be results focused and resource allocation should be driven by progress towards meeting the target.

Success of law enforcement efforts is indicated by the level of compliance observable in the driving community and not by the number of infringements or warnings given. Compliance is measured by the percentage increase in seat-belt wearing rates. Other performance measures are the number of checkpoint operations, target operations, educational lectures and individual and media warnings. The police should also publicize the benefits of their programme to encourage a strong community consensus for using seat-belts.

Apprehension of violators of the seat-belt laws will largely be done through checkpoints and roadblocks, mobile highway patrols and police stationed at locations where vehicles stop, such as service stations, tollgates and traffic signals.

Enforcement operations should be well planned, with all traffic officers being appropriately trained and briefed. Safety should be paramount, with due consideration given to the safety of the interception officers and the driving public, the safe use of equipment and the selection of checkpoint sites.

#### 4.4.4 Police training

Police officers must be trained in effective strategies and tactics to achieve maximum success. These include:

- knowledge of the law;
- understanding how seat-belt wearing reduces the risks of injuries (even in low-speed crashes);
- police officers on and off duty must obey the law and must set an example;
- understanding how to set up safe and effective roadblocks and checkpoints for maximum on-road public exposure and enforcement. This will include signage or large banners indicating to all the driving population what enforcement is being undertaken, e.g. “Seat-belt checkpoint” or “Seat-belts save lives”;
- how to target areas with high rates of non-compliance;
- how to provide effective advice and education to motorists;
- understanding the impact of crashes on financial and human resources, both as regards the community and as regards the resource savings to police and emergency rescue services when an effective law enforcement programme is undertaken.

#### 4.4.5 Processing penalties

Choosing penalties is dealt with as part of the legislation process in section 4.2. As well as considering phasing in more severe penalties, it is important that penalties are processed quickly and equitably regardless of the status of those who have broken the law. Fines can be collected quickly and efficiently without a court process through a ticket system or by on-the-spot fines, as follows:

- Written tickets can be issued on the spot, requiring the offending driver to pay a fine to a given department or bank by a specified date or submit to another penalty such as a driver training course. To operate this method effectively, a computerized database should be set up to record all offences. Fixed penalties can use a combination of fines and demerit points.
- On-the-spot fines are levied in some countries whereby motorists caught driving without wearing seat-belts have to pay a fine directly to the police officer. The money is then passed on to the transportation authority.

The former method is preferred as the opportunity for corruption is somewhat reduced and also it provides scope for including seat-belt violations in a penalty points system. It also enables alternative penalties to be issued, such as attendance at a driver training course.

#### 4.4.6 Overcoming obstacles to enforcement

Enforcement authorities will often have limited resources and checking seat-belt violations will compete with other policing priorities. Agreeing a national and local seat-belt wearing target is therefore crucial in obtaining commitment and the necessary resources.

Political support is fundamental to sustained outcomes. Scarce police resources must be used effectively and efficiently to maximize the value of law enforcement operations.

Table 4.5 shows some barriers that can arise when trying to implement a seat-belt law, together with their remedial actions.

**Table 4.5** Overcoming barriers or obstacles to effective implementation of the law

Barriers	Remedial actions
Limited police resources	<ul style="list-style-type: none"> <li>• Strategic planning for intensive high-profile, high-visibility enforcement activity – resource deployment and coordination</li> <li>• Combining education and enforcement</li> <li>• Strong media campaigns</li> <li>• Community support campaigns</li> <li>• Allocation of additional traffic officers</li> </ul>
Competing police priorities	<ul style="list-style-type: none"> <li>• Government and senior police officers understanding the real economic and human costs of road trauma compared with the relatively lower costs of enforcement</li> <li>• Appreciating the cost savings that can be achieved by strategic traffic enforcement</li> </ul>
Complacency in enforcement	<ul style="list-style-type: none"> <li>• Enhanced training of police officers, supervisors and police management, with emphasis on the risks to drivers, their passengers and the community</li> </ul>
Police officer sympathy in favour of the driver: <ul style="list-style-type: none"> <li>• Seat-belts stated to be uncomfortable, inconvenient or unnecessary</li> <li>• Cost of fines</li> </ul>	<ul style="list-style-type: none"> <li>• Education of police officers about the associated risks of not wearing seat-belts</li> <li>• Community education</li> </ul>
Inadequate or ineffective policing capability or strategies and the perception that enforcement is too difficult with such extensive non-compliance	<ul style="list-style-type: none"> <li>• Development of an integrated law enforcement strategy</li> <li>• Identification and publication of minor successes</li> <li>• Modelling on “good practice” examples of success</li> <li>• Targeted seat-belt law enforcement</li> </ul>
Corruption, including: <ul style="list-style-type: none"> <li>• Police officers collecting fines and not passing them on to government authorities</li> <li>• Illegal and unethical receipt of monies as payment to overlook an offence (bribery)</li> </ul>	<ul style="list-style-type: none"> <li>• Anticorruption measures</li> <li>• An appreciation that corruption undermines any road safety intervention</li> <li>• Enhanced education and training of officers</li> <li>• Salary reviews of traffic officers after appropriate training</li> <li>• Promotion of a code of ethics/behaviour</li> </ul>



#### 4.4.7 Section summary: increasing seat-belt usage through enforcement

Consistent enforcement of seat-belt laws by the traffic police is one of the most effective methods of raising and maintaining high levels of wearing rates among vehicle occupants.

The primary objective of enforcement is to ensure that seat-belts are worn by all vehicle occupants on all roads at all times. The primary outcome of enforcement efforts is an increase in wearing rates, leading to a reduction in the number and severity of road crash injuries.

A checklist of enforcement activities might be as follows:

- Before starting an enforcement campaign government and other agencies should take the lead and make seat-belt use compulsory for their own staff; the public should be informed about enhanced enforcement of the seat-belt law, any changes to the law, and penalties for non-compliance.
- Strengthen law enforcement efforts by developing a strategic, intelligence-led approach, including increased visibility of enforcement; repetition of enforcement campaigns; strict and consistent enforcement; and well-publicized enforcement.
- Examine the capacity of the police force to increase enforcement efforts and explore how to integrate seat-belt enforcement into other enforcement activities.
- Consider phasing in police action after apprehending violators, such as starting by issuing warnings and explaining the new law before issuing fines.
- Consider nominating a “champion” in the police field to ensure ownership within the enforcement community and assist in ensuring the sustainability of seat-belt enforcement efforts.
- Ensure that penalties are processed quickly and equitably regardless of the status of those who have broken the law.
- Agree a minimum annual target for level of compliance based on benchmark surveys of seat-belt wearing.
- Agree a national and local seat-belt wearing target as a basis for obtaining commitment and the necessary resources.

## 4.5 Increasing usage: voluntary measures

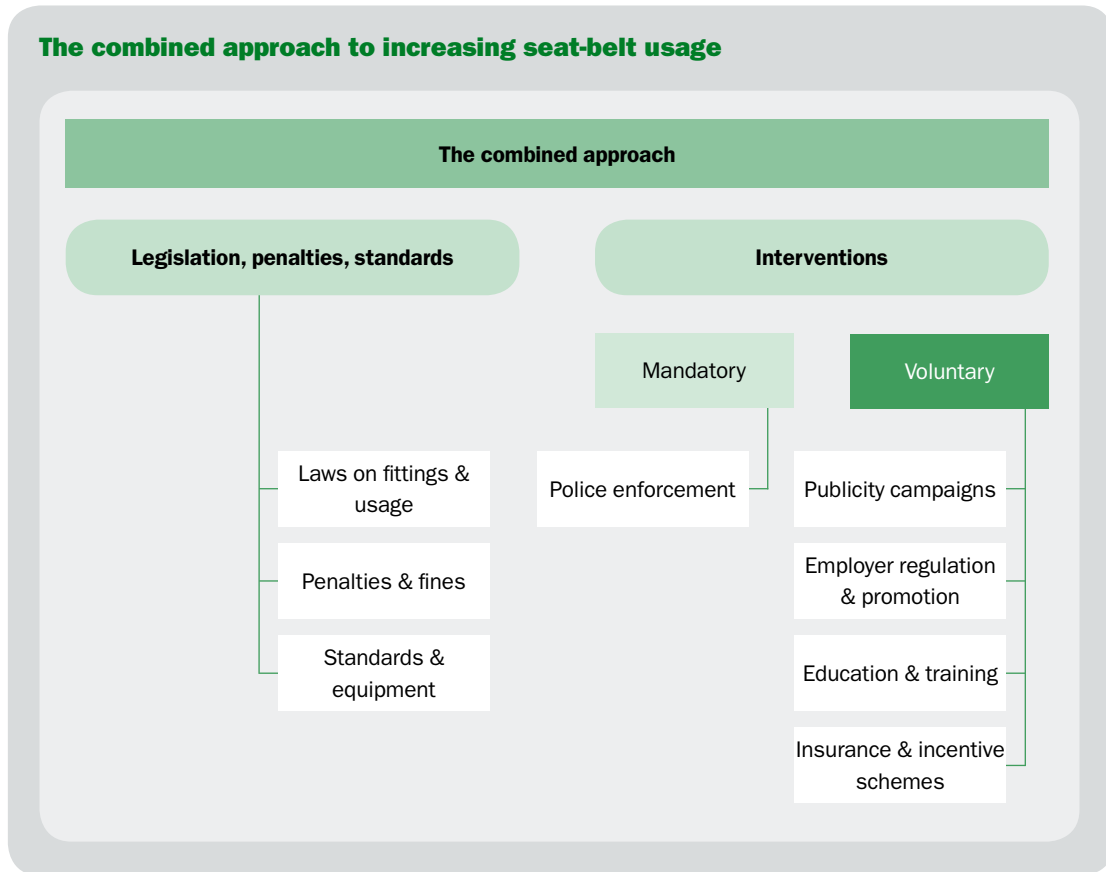

Voluntary measures, including publicity campaigns, education and training, employer regulation and promotion schemes and insurance and incentive schemes, are critical in raising awareness and understanding of the benefits of using a seat-belt in support of legislation and enforcement efforts, encouraging voluntary use, and ultimately bringing about a sustainable long-term increase in seat-belt wearing rates.

## 4.6 Increasing usage: publicity campaigns

The publicity campaign is usually the most visible part of an initiative to raise seat-belt wearing rates and is often mistaken for the whole initiative itself. A typical publicity campaign could incorporate the components outlined in Table 4.6.

**Table 4.6** Publicity campaign components

Campaign component	Reason for considering
Television advertising	Large target audience reach. Communicate short key message. Visual and aural communication. Not good for detailed messages.
Radio advertising	Large target audience reach. Short message. Message while driving through car radio. Aural communication.
Press advertising	Large target audience reach. Short message. Use as link to media public relations stories. Limited by literacy levels of audience. Can be basis of word-of-mouth communication.
Outdoor advertising, e.g. road signs, taxis, police vehicles, buses	Short message targeting the audience while using the road. Can reach a range of road users. Can reinforce and extend television and press images.
A project launch event	Broad public awareness, government exposure, free media exposure. Opportunity for two-way communication at media briefing. Can form the basis of word-of-mouth communication.
A series of public relations activities	More detailed explanations of initiative. In-depth analysis. Public credibility. Exposure for campaign figureheads. Can be linked to public events and community meetings. Provides opportunity for local participation and to “localize” campaign messages.
Media interviews, presentations and articles	Detailed explanations of initiative. Public credibility. Exposure for campaign figureheads. Opportunity for two-way communication.
A kit of activities to be undertaken in regional or local areas	Support for regional contributions, support for regional media and public relations activities. Opportunity to localize the issues. Potential to profile local figureheads. Basis of information for public or village meetings.
Activities designed and funded to operate in local communities	Provide information to support continuing local media coverage. Can establish local ownership of issues and support action at local levels.
Sponsorship of sporting and cultural events	Good for campaign positioning and branding. Can access high-profile and highly credible personnel. Link with specific road safety issue can be tenuous unless properly thought out.
Publicity for the enforcement activities undertaken	Enhance deterrent effect to generate short-term behaviour change. Powerful influence on immediate behaviour provided enforcement level is sufficient to be acknowledged by the public.
Interview key figures: police, celebrities and religious leaders	Exposure for campaign figureheads. Campaign credibility. Opportunity for two-way communication.
Community or school-based promotional events	Enhance public/target group interest. Opportunity for positive behaviour reinforcement. Link to school curriculum teaching on road safety for children. Opportunity for parents’ road behaviour to be influenced through their children. May be a weak influence if community culture does not support assertive children’s behaviour.



Road safety publicity refers to the whole amalgamation of activities designed to inform, advise, encourage and persuade the target audience to undertake a particular behaviour. On its own, publicity is of limited effectiveness, but it is an essential part of a coordinated programme in support of legislation.

A campaign that is undertaken only once – even if it includes dedicated enforcement – will not have a long-term sustainable impact on increasing seat-belt wearing; regular enforcement accompanied by a repetition of the key messages is needed.

Publicity campaigns are important and can be effective even if legislation requiring seat-belt use is not yet in place, through highlighting the humanitarian and economic benefits associated with the use of seat-belts. It is through the use of such campaigns that increased voluntary use is facilitated. A review of wearing rates in 15 countries showed that the average level of voluntary usage prior to the introduction of legislation was 25% of the population.

It is vital to the success of seat-belt legislation that the benefits are understood. By increasing awareness stakeholders are reducing any potential resistance that may occur to the introduction of legislation at a later date.

Conducting a publicity campaign will require expertise in marketing or advertising, development of specific campaign objectives, articulation of the campaign messages,

identification of the target audience, specifying a time frame for implementation and a methodology for evaluating the initiative.

#### 4.6.1 Objectives of the campaign

A seat-belt campaign aims to persuade vehicle occupants to wear a seat-belt, and to modify their behaviour through acceptance of the proven socioeconomic and humanitarian benefits.

The most important aspect of any campaign is to have a clear idea of what the campaign is meant to achieve. The objectives may be stated in quantifiable terms. For instance, the public might be told that “by December 2008 it will be required by law that all car drivers and passengers wear a seat-belt”.

For a campaign to be successful, it is important to employ social marketing tools. Social marketing is an effort to impact the culture of a community in order to persuade it to accept, modify or abandon ideas, attitudes, practices and behaviour (15). For a campaign to follow the principles of social marketing:

- it must focus on a single-minded proposition;
- its execution must be distinctive;
- its target audience must be clearly defined.

Various objectives are possible, depending on the existing legislation and rate of seat-belt use. They include:

- to increase public awareness that seat-belts can prevent serious injury and death;
- to increase awareness that every driver and passenger is safer with a seat-belt;
- to encourage people to purchase cars with seat-belts fitted and to use them;
- to convey the message that use of a seat-belt is now mandatory;
- to inform people that seat-belt use is now being enforced, and to explain the penalties;
- to promote enforcement of the seat-belt laws by the police.

Each of these objectives should be quantifiable. It is therefore necessary first to ascertain:

- the current level of awareness of the safety value of seat-belts, their availability and cost, and the legal requirements for seat-belts (see section 4.6.2 on market research);
- the current level of seat-belt use, by both drivers and passengers, by seating position, in urban and rural areas;
- the current level of enforcement (see case study from Argentina).



### CASE STUDY: “Let’s fight for life” seat-belt campaign, Argentina

Luchemos por la Vida (Let’s fight for life) was founded in 1990 with the aim of promoting seat-belt use in Argentina. Before starting the seat-belt campaign, a systematic observation of seat-belt use among drivers and front seat occupants in Buenos Aires was undertaken, and regular surveys have been carried out every year since. Observations were taken at different sites in the city, at both day and night times, on holidays and working days, and for different types of vehicles. At least 4000 vehicles were surveyed each time. Only 0.2% of car occupants were observed to be wearing a seat-belt in November 1990.

In March 1992, after a first and very simple campaign on radio and television, percentages went up to 3.1% for drivers and 2.2% for front seat passengers.

In July 1992 seat-belt use became a legal requirement in both front and rear seats and usage rose to 32% without any enforcement. The impact of the legislation was short lived due to the complete absence of enforcement. By July 1995 only 13% of drivers and 11% of front seat passengers were wearing seat-belts. A new law and campaign raised rates again to 32% for drivers and 30% for front seat passengers in April 1996, but again without enforcement rates declined to well below 20%.

Luchemos por la Vida launched a new campaign, “Let’s save 1100 lives by using the seat-belt”, in May 1999. The campaign used intense television and radio coverage based on the objections, myths and

false beliefs of the majority of the population regarding the use of seat-belts, and provided information on the consequences of not being buckled up in the case of an accident. There was also a campaign prompting people to write letters to the president, the governors and the city mayors stressing their responsibility for 1100 deaths each year due to lack of control of seat-belt use. Advertising at the roadside and at tollbooths on highways was used, and the campaign was helped by a high-profile accident in which a former president nearly died after being ejected from his car. The wearing rate for drivers rose to 27% in November 1999, but as before it gradually declined again to 22% in June 2004.

As a result of campaigns and lobbying of the authorities, enforcement was initiated in Buenos Aires in October 2004 with advertisements and strong police action. The effect was measured by Luchemos por la Vida and at the end of the first week rates were 86% for drivers and 83% for front seat passengers. A survey of drivers showed that 98% considered seat-belts to be useful in case of an accident, and 81% agreed with seat-belt enforcement.

Although the enforcement effort has not been sustained, wearing rates in March 2005 were still over 75%. Luchemos por la Vida attribute this to the awareness-raising campaigns that, over a long period of time, have led to the change that was initiated by the enforcement campaign becoming permanent and habitual (16).

#### 4.6.2 Creating campaign messages

Before developing the communication messages for a seat-belt use campaign, the factors restricting seat-belt use need to be identified, through both local knowledge and market research. The key target audience also needs to be determined, for example front seat or rear seat vehicle occupants, or those employing child restraints (see section 2.2.2 on assessing seat-belt and child restraint wearing rates).

Market research is used to determine the target audience’s knowledge of legislation as well as the opinions, beliefs, fears and motivations of high-risk groups that are known to be involved in drink-drive crashes. A first step in this process is to identify the target audience involved and then collect information from them that is relevant for the campaign.

### Diagnostic testing

The first step in developing campaign messages is to assemble a small group of individuals representing the main target group. The goal of discussions is to:

- identify and understand why these individuals do not use seat-belts;
- understand the incentives that might be used to change the attitude and behaviour of the target group.

### Develop campaign messages and materials

On the basis of the information received from the diagnostic testing carried out with the target audience, a range of messages and campaign materials can be developed to encourage a change in thinking and behaviour in relation to seat-belt use. Preparation of these products is commonly undertaken by advertising agencies contracted by the road safety authorities.

The draft campaign messages and materials should then be tested with small groups of individuals representing the target audience by an independent market research agency contracted for this purpose. The agency that created the materials must not be allowed to market-test their own materials, as they are unlikely to be self-critical. The purpose of testing the materials is to determine the most effective message and method for communicating to the target audience, and changing their perception and behaviour in relation to seat-belt use.

The campaign message should:

- be simple, consistent and memorable;
- be appropriate to the conditions of the particular country, including its social and cultural standards;
- not cause offence to any group;
- be relevant to the target audience chosen, and not necessarily aim to apply to the whole population.

It is useful to make the message itself the “brand” for the campaign. The product being sold is “Wear a seat-belt”, not the government agency responsible for the campaign. Tailored and targeted messages often work best in road safety (2).



*The central human and emotional message of the campaign (Por Amor use el Cinturón - 'For love use your seat-belt') was based around the concept of love and responsibility, with a campaign icon featuring a traffic sign with a heart secured by a seat belt.*

Automobile Club of Costa Rica

### 4.6.3 Reaching the target audience

The target audience must interpret campaign messages as relevant to them.

Depending upon the budget, objectives and target audiences for the campaign, a range of media will usually be employed to convey its messages. Some media are more appropriate than others for a particular target group; for example, newspapers may be better for middle-aged people, cinema films for younger people and radio for those in rural areas. A competent advertising agency will be able to advise on the best way to reach different target audiences.

The campaign should adapt its approach for changing audiences, while keeping the main message consistent. The campaign, for instance, may initially operate in urban areas, or among younger people. Different approaches would then be needed to convey the same message to rural or older audiences.



#### CASE STUDY: **Seat-belt campaign targeting young people who are rear seat passengers, Poland**

The first national seat-belt campaign in Poland started in the middle of September 2005. On the basis of research results showing that seat-belt wearing rates were lowest amongst young people sitting in rear seats the target group chosen was young people (18–24 years of age) and the message was addressed mainly to those sitting in the rear seat. Research showed that the main reasons why people did not buckle up were:

- they thought they could control the traffic situation and they believed that they were in control of the risk;
- they lacked the habit of wearing seat-belts.

The campaign objectives were to increase the wearing of seat-belts and to make wearing seat-belts a social norm by:

- building awareness that road crashes are a real and unpredictable hazard and that non-use of a seat-belt can cause death and serious injury;
- refuting false beliefs and myths related to seat-belts;
- creating the habit of wearing a seat-belt in the rear.

Evaluation results showed that 93% of the targeted audience, i.e. young people 18–24 years of age, was reached. The declared utilization rate of seat-belts in the back seat increased from 34% to 66%, while the observational study showed an overall growth in seat-belt use from 38% to 50% in the back, and from 74% to 84% in the front. A 10% decrease in fatalities was recorded in the campaign time, which is traditionally the period with the highest crash fatality rate in the country (17).

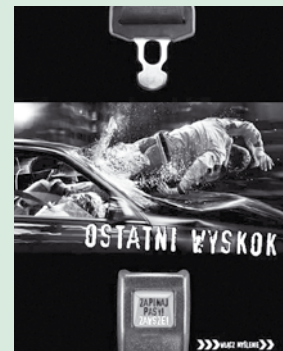



#### 4.6.4 Creative concepts

Creativity within a publicity campaign is all too often overlooked. A review of publicity campaigns worldwide has highlighted a number of common creative elements that can potentially form the basis of future campaigns (Table 4.7).

**Table 4.7 Common themes for improved creativity in road safety publicity campaigns**

Common themes	Desired outcome
Shock tactics such as visuals of crash dummies; real-life representations (see note on shock tactics)	Emotional response to stimulus
Law enforcement	Moral decision. Fear factor: the desire not to be banned from driving, wanting to retain independence and status
Inconvenience (e.g. on-the-spot fines)	Lifestyle decision, not wanting a reduction in income
Awareness, education, ability to relate to oneself	Educational decision based on level of knowledge
Peer endorsement	Creating social awareness and acceptability through the use of high-profile figures such as sports stars or television personalities
Memory/recall	Subconscious, almost automatic decision
Frequency of message/call to action	Instant decision/compliance

Creativity applies not only to the concept but also to planning and choice of media, which will vary according to national setting and budget available. Market research should aim to indicate the types of media through which specific demographic groups can be reached, for example early morning radio for drivers on their way to work, with reminders through advertising boards at petrol stations and car parks.

#### NOTE

##### Shock tactics

The use of shock tactics has been widely utilized in road safety publicity campaigns, based on the belief that high-impact images will make drivers relate emotionally to their responsibilities on the road. However, what is most likely to ensure the effectiveness of any road safety campaign is clear understanding and credibility of the message for the specified target audience.

Simply using shock tactics to deliver a message can accustom the target audience to the shock, and therefore each subsequent advertisement has to highlight more shocking images to have the same effect.

Cost can be a major factor in considering which media to use. Research has suggested that low-cost publicity can be just as effective as high-cost campaigns, provided that the target audience understands the message (18). More widespread dissemination of road safety messages can however be achieved through a large budget, although government and corporate assistance can reduce advertising costs significantly.



#### **Role model initiatives**

Using selected role models can influence people to wear seat-belts before legislation is introduced. The particular role models chosen will depend on the group being targeted in the campaign. The target group could be young people, who usually make up a significant proportion of drivers and passengers involved in crashes. In this case, the role models publicly seen wearing seat-belts might be well-known singers, film or television stars or sports stars. For a different target group, the role models could be prominent professionals, doctors or successful business people. Young parents might be targeted with examples of celebrities whose children are using recommended child restraints.



#### **CASE STUDY: Jordanian awareness-raising campaign**

A Jordanian awareness-raising campaign chose to blanket the whole country through television, radio, newspapers, mosques and churches. This was particularly effective, increasing wearing rates by 47%. Television advertising can prove costly; however, in Jordan both television and some radio stations are government owned and airtime was not included in

the costs of the campaign. Three one-hour televised meetings were held, discussing the benefits of seat-belts, plus 50 30-second adverts. The most popular radio station was chosen to deliver road safety messages through programmes of general interest. These lasted longer than those on television (20).



## CASE STUDY: **Seat-belt campaign, Sakhalin Island, Russia**

The Sakhalin Island seat-belt campaign is supported by the Sakhalin State Inspectorate for Traffic Safety (GIBDD) and Sakhalin Road Safety Partnership. The campaign is undertaken annually and monitoring of seat-belt wearing rates is undertaken regularly through observational studies and through data collected by the traffic police during driver checks and at the crash scene. Components of the project include education and awareness raising, enforcement and effectiveness assessment.



### **2005 seat-belt campaign**

Before starting the development of this campaign, a detailed public opinion survey was undertaken on Sakhalin Island to identify the reasons that local residents chose not to wear a seat-belt. This was recognized as being of key importance in designing a campaign that would be effective in addressing incorrect assumptions and inaccurate beliefs, allowing the project team to tailor the initial campaign ideas and messages accordingly. Before the campaign launch, all campaign materials were thoroughly tested in a number of externally managed focus groups. This ensured that the materials and messages that had been developed would be effective in reaching their target audiences (and where they were not, the project team was able to make changes).

The campaign was implemented in two phases. First, an awareness campaign was launched with high-profile media coverage of key messages emphasizing why seat-belts should be worn and correcting false assumptions about seat-belts held by members of the public. Second, and most critically, an enforcement campaign was launched to reinforce the fact that the use of seat-belts was the law, and failure to use a seat-belt would be punishable by a fine. The project team identified that, although it was Russian law that seat-belts should be worn, seat-belt enforcement was not regarded as a high priority

of the GIBDD due to lack of enforcement officers. The head of the local GIBDD agreed to ensure that enforcement of seat-belt usage on Sakhalin Island would be intensified during the enforcement phase of the campaign.

Research conducted before and after the 2005 campaign showed an increase in wearing rates in urban areas (Yuzhno-Sakhalinsk) from 3.8% to 13.9% and on rural roads from 26.8% to 51.8%.

### **2006 seat-belt campaign**

In an effort to bolster wearing rates a second campaign was launched in mid-2006. The project team evaluated lessons learned from the first campaign and chose to focus more effort on:

- ensuring consistent enforcement throughout the entire campaign period;
- creating stable positive opinions of the advantages of buckling up;
- reaching more people by using a larger range of mass media;
- implementing the campaign during the summer period, when crash rates are usually highest in the Sakhalin Oblast.

The geography of the 2006 campaign was expanded by conducting campaign launches in smaller communities. Video materials and radio clips were updated to reflect the summer season and higher level of enforcement. The campaign started with active communications in local media and lasted from May until the middle of November. Additional research was undertaken during and after the campaign to measure the effectiveness of the project and to study the opinion of the population with respect to the approach taken in conducting the campaign.

The public opinion survey showed that 86.7% of the population had seen campaign materials, and that the most effective means of communicating were television, radio and billboards.

The following measures proved particularly critical in developing and implementing two successful campaigns:

- winning high-level political support for the campaign;

*Continues...*

*Continued from previous page*

- engaging with local stakeholders representing diverse sectors;
- well-promoted and properly launched enforcement of traffic laws;
- professional development of campaign materials using focus groups;
- pre- and post-campaign data collection on wearing rates based on international good practice;
- pre-launch educational events for media and local traffic police to raise the awareness of these key stakeholders about the risks involved in not wearing a seat-belt;
- high-profile media coverage using local true stories;
- debrief of key stakeholders after the campaign.



Research conducted before and after the 2006 campaign showed an increase in wearing rates in urban areas (Yuzhno-Sakhalinsk) from 14.3% to 22.7% and on rural roads from 56.1% to 77.9% (19). Observational studies in 2007 showed wearing rates had increased to 64.8% prior to the 2007 campaign and jumped to 76.6% after the 2007 campaign.

#### 4.6.5 Selecting an agency for the campaign

A successful publicity campaign may be carried out by qualified personnel within a government department, but usually needs the expertise of a professional marketing or advertising agency. Overall control of the campaign should, however, stay with the government agency responsible. The campaign may also require the services of a public relations agency and a research agency, unless the government agency can provide these services itself.

The first step in selecting an advertising agency is to issue a tendering document outlining the overall aims and objectives of the campaign, the time schedule and the budget. The purpose of this tendering document is to assess the ability of responding agencies to do the work. From their initial applications, a shortlist of agencies should be drawn up, based on:

- the agencies' previous experience with social marketing campaigns;
- their creative ability;
- their physical location;
- their media purchasing ability;
- their size.

The short-listed agencies are then asked to tender for the work by providing creative ideas, plans for media work and budgets.

The steps involved in setting up a seat-belt publicity campaign are illustrated in Figure 4.5.

**Figure 4.5** Steps involved in setting up a seat-belt publicity campaign

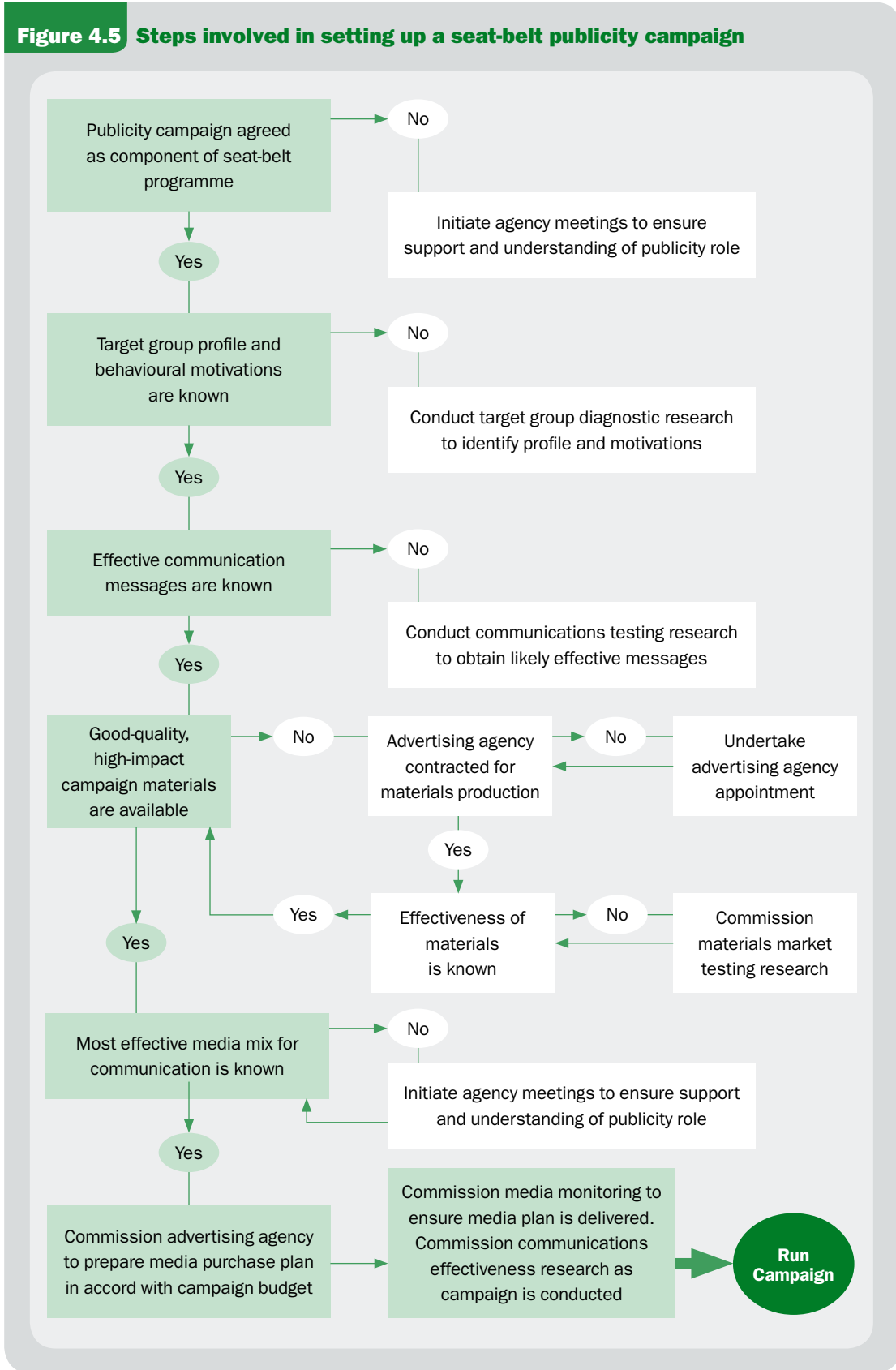

#### 4.6.6 Working with the media

The media – including the printed media, the broadcast media and the Internet – serve various functions in any public education campaign. They will be interested in and will cover the campaign itself – its objectives, contents and progress. They may support it, but they may equally be critical, to the extent even of running a counter-campaign. It is therefore important that the media are informed about a forthcoming campaign and that the reasons for the campaign are set out clearly and strongly.

An ongoing part of the campaign should be to keep the media regularly informed about its progress and how it is meeting its targets. This can be done either by the government agency or by an external public relations agency.

#### 4.6.7 Campaign stages in relation to seat-belt legislation

The stages of a seat-belt publicity campaign in respect to related activities such as changes in the law and police enforcement should be carefully considered. Coordination among the initiatives is critical. The stages should include some or all of those indicated in Table 4.8, depending on the current situation of seat-belt legislation and enforcement.

**Table 4.8 Campaign stages in relation to seat-belt legislation**

Legislative situation	Publicity activity and objectives
No seat-belt legislation in place	Public education to encourage voluntary seat-belt use by: <ul style="list-style-type: none"> <li>• explaining why wearing seat-belts is beneficial;</li> <li>• informing potential wearers about their availability and cost;</li> <li>• giving information on when seat-belt use will become compulsory.</li> </ul>
New legislation adopted but not yet in effect	An advisory stage as the date for new regulations approaches to: <ul style="list-style-type: none"> <li>• ensure the date set for the introduction of the new legislation is one that is easily remembered;</li> <li>• reinforce the importance of wearing seat-belts;</li> <li>• explain the penalties for failing to comply with the new regulations.</li> </ul>
Legislation goes into effect	A marketing stage – probably the single most important stage – that should: <ul style="list-style-type: none"> <li>• explain why wearing seat-belts is beneficial;</li> <li>• give further details on the consequences of not wearing seat-belts, both from the point of view of possible injury and of the risk of penalty fines;</li> <li>• reinforce the message for those who wear seat-belts only irregularly.</li> </ul> <p><i>Note:</i> During this stage, it may be best to enforce the regulations with warnings only at first, though the campaign will become most effective when the regulations are fully enforced.</p>
Legislation firmly in effect	Periodic but regular maintenance to: <ul style="list-style-type: none"> <li>• reinforce the message for those who wear seat-belts;</li> <li>• remind those who have become lax in wearing seat-belts;</li> <li>• continue to explain the consequences of not wearing seat-belts.</li> </ul> <p><i>Note:</i> Periodic marketing will reinforce a message, and is more cost effective than continuous marketing.</p>



### CASE STUDY: **Seat-belt wearing legislation and campaigns, United Kingdom**

Manufacturing legislation making it mandatory for cars built in Europe to have seat-belts fitted in the front was implemented in 1965. Despite the new legislation, wearing rates were low and in the early 1970s a series of commercials were filmed using a well-known celebrity highlighting the dangers of being thrown through a car windscreen. This advertising campaign lasted for over a decade, increasing awareness of the benefits of seat-belt use and preparing the ground for legislation in 1983 making it compulsory to wear seat-belts in the front seat.

Following legislation, front seat-belt wearing rates rose to over 90%, a level that has been consistently maintained. In 1989 it became compulsory for all children under the age of 14 years to wear seat-belts in the rear of a car, and compulsory rear seat-belt use was extended in 1991 to include all passengers. These were primary laws and have been constantly enforced.

Enforcement, education and publicity formed the basis of future campaigns to increase wearing rates, particularly amongst rear seat passengers and teenagers. Television and radio commercials were used to show the risk to unbelted passengers, targeting all adults and parents.

In 1998 only 43% of adults were wearing seat-belts in the rear and a new campaign was developed. Research showed that many front seat passengers

were killed each year by unbelted rear seat passengers colliding with them. A campaign idea based on conveying the message about being responsible for injuring someone else, and the degree of uncontrollable movement if unbelted at the time of a crash, was found to be a powerful message. As a result the "Julie" campaign, which showed a teenage boy being thrown forward and killing his mother, was developed. The campaign was highly successful, increasing agreement that unbelted rear seat passengers could "kill or seriously injure the driver" from 46% to 62%. Importantly, rear seat-belt wearing increased from 48% to 59% after the campaign. The advertisement continued to be shown until 2002, and by April 2006 the adult seat-belt wearing rate in the rear was 69%.

The latest television advertisement – "**Backward**" – shows what happens to three young men in a car crash when they are not belted in, then the sequence is rerun with them wearing seat-belts. The aim of the seat-belt campaign is to tell drivers and passengers of the importance of wearing a seat-belt both in the front and the back of a vehicle. This is based on the insight that the real crash happens inside the car (impact with the screen, dashboard and other passengers). The strategy also seeks to target short trips at low speeds in urban areas, as it is often on these types of journeys that drivers do not belt up (21).



### CASE STUDY: **Think Before You Drive** campaign, Peru

The Touring and Automobile Club of Peru launched the Think Before You Drive campaign on 29 September 2006. Campaign staff in dummy outfits took to the streets with the traffic police to remind motorists that the new seat-belt legislation was coming into force as of 1 October 2006.

This new legislation, which extended compulsory seat-belt wearing to the back seats, was the result of the Automobile Club's Por Amor seat-belt campaign, emulating the successful Por Amor Use el Cinturón campaign in Costa Rica in 2003–2005 (see case study, section 4.2.5).

A press conference was held with the many partners of the campaign, including the Head of Traffic Police and the Health Minister, and both gave the good example of buckling up on the club's seat-belt slide. The club demonstrated that in Peru, 3600 people die and 600 000 people are injured in road accidents each year. This leads to a great deal of suffering and at times financial distress among those who are left behind, but the country also suffers: the financial loss due to the accident toll is estimated at up to US\$ 1 billion per year. The club assisted the traffic police during their road checks on seat-belt use. On the first day of police enforcement 234 tickets were issued, 70% to motorists who for some reason had taken out the seat-belts that their cars were normally equipped with. Of the fines, 30% went to taxi drivers, who were also given a ticket if their passengers were not wearing a seat-belt. Most people waited

until the last minute to have seat-belts installed, which resulted in long queues at sales points and the doubling of prices within two weeks. As a result the Transport Ministry decided to delay phasing in installation of seat-belts in the back for some types of transport, such as intercity buses, until November (10).



#### 4.6.8 Evaluating the campaign

Monitoring and evaluation is an integral element of all road safety campaigns. It is through the implementation of monitoring and evaluation techniques that stakeholders are able to determine the success or failure of a campaign, and therefore design future campaigns accordingly.

The primary outcome of a seat-belt campaign is seat-belts worn by all drivers and passengers. This outcome is best measured by regular, independently conducted, observational surveys, before, during and after the campaign. Ideally, surveys should take place at six-monthly intervals during the campaign, and annually once the campaign has reached its maintenance stage. The cost of surveys should be built into



the overall cost of the programme. Module 2 described methods for carrying out observational surveys.

The survey should be sufficiently large to identify significant differences between different age groups, men and women, drivers and front seat and rear seat passengers, cities and smaller towns, urban roads and highways, and different regions of the country. As differences are found in surveys, it may be necessary to adjust the campaign focus more towards those groups with lower seat-belt wearing rates.

Other less direct outcomes may also be measurable. These include knowledge and attitudes about seat-belt wearing, police ticketing rates and – where crash statistics are available – deaths and injuries among drivers and passengers of motor vehicles. Knowledge and attitudes are often slower to change but can be measured by regular, possibly annual, surveys conducted by interview. As with the observational surveys, these interview surveys should be able to detect differences between population groups. It is sometimes possible to use regular omnibus surveys by adding a number of questions relating to attitudes to seat-belt wearing and to other road safety measures. This can be very useful in providing wider information with which attitudes to safety can be correlated. Police and casualty data can also be useful, but they are subject to numerous external influences and may not accurately reflect the effect of the campaign.

## **4.7 Increasing usage: other voluntary measures**

This section includes consideration of employer regulation and incentive schemes; education and training; and insurance and public incentive schemes.

### **4.7.1 Employer regulation and incentive schemes**

Employers have a significant role to play in increasing seat-belt usage, especially in those countries where legislation and enforcement have not yet been widely implemented. Companies and government organizations can help save lives and injuries of both their employees and contractors by:

- fitting good quality seat-belts to company and contractor vehicles;
- making seat-belt wearing a company regulation both for work-related journeys and for staff commuting trips;
- including seat-belt fitting requirements and wearing rules in contracts with road transporters;
- carrying out regular checking of seat-belt usage by staff and contractors;
- providing incentives for compliance and penalties for non-compliance;

- informing and training staff and contractors on good driving practices, including seat-belt use;
- adopting comprehensive road safety management systems with road safety targets for which all staff, especially senior management, are held responsible.

For example, during a number of awareness-raising campaigns in Australia during the 1960s, some private sector organizations voluntarily equipped their fleet vehicles with seat-belts. This helped raise wearing levels from almost zero to 25%, despite the fact that installation of seat-belts in road vehicles was not common practice at that time (22). A similar initiative in India led by a leading multinational lubricant manufacturer (see case study) has benefited not only its own truck operations but also other companies who can now buy the safer cab and seat design.



### CASE STUDY: **Private sector initiative, India**

A leading multinational lubricant manufacturer in India adopted an integrated safety management system to reduce road risks and achieve its goal of eliminating fatalities and serious road crashes. The organization typically had more than 500 vehicles on the road at any one time and these were largely driven by third-party contractors.

Over four years ago most of the trucks had wooden cabins and bench seats, which provided poor safety features and little occupant protection. These cabins were usually constructed by traditional coach builders and not by the original vehicle manufacturer.

To improve vehicle safety, the organization worked with vehicle manufacturers to develop a safe cabin as original equipment. This included improvements in all-round visibility, adjustable fitted seat-belts and adjustable seats for the driver and the driver's assistant.

In three years the organization has voluntarily introduced the new seats and fitted seat-belts in over 2000 trucks, and encourages transport contractors to purchase trucks with these cabin specifications as original equipment.



To raise seat-belt wearing levels, the organization has made seat-belt wearing mandatory as part of the contract agreements. Spot checks are carried out by the organization and penalties are issued for non-compliance. Regulation and compliance monitoring have been supported by a major engagement programme with transporters and drivers to ensure that they understand the reasoning behind seat-belt rules and how seat-belts help save lives. The organization also recognizes and rewards transporters and drivers for practising safe driving.

### 4.7.2 Education and training

Community education programmes on seat-belts are critical in raising awareness and understanding of the benefits of using a seat-belt, encouraging voluntary use and ultimately bringing about a sustainable long-term increase in seat-belt wearing rates.



Light Board from CECF Ad Co Ltd

As with publicity campaigns, the educational process should never be viewed as short term. Constant reinforcement of the message and targeting of an ever-evolving audience are required in order to continually improve the trend in seat-belt wearing.

Education and public information programmes to encourage seat-belt use can:

- stimulate and reinforce behavioural change;
- increase public support;
- influence social norms, making seat-belt use more socially acceptable;
- create a supportive environment for the passage of laws and policies that increase seat-belt use.

There are a number of approaches that can be used to inform vehicle owners and occupants on the need to wear seat-belts, in addition to large national publicity campaigns. Some of the key options are shown in Table 4.9.

**Table 4.9** Key education and training approaches

<b>Actor</b>	<b>Approaches</b>
Health personnel and officials	Provide literature and advice, for instance to new parents on the need to use child restraints, or to patients who have been involved in traffic crashes, or through health promotion presentations or exhibitions.
Manufacturers	<p>Provide guidance on the use of safety features within a vehicle, e.g. information within the vehicle manual informing the vehicle owner how to identify damage or faults to a seat-belt that indicate that replacement is required.</p> <p>Commercial marketing by vehicle manufacturers and retailers, particularly for child restraints, can play an important role in increasing voluntary seat-belt use.</p>
Road safety personnel	Have the expertise to increase the knowledge of the whole community, using a wide range of methods. They should also consider providing resources and holding special events educating vehicle occupants about how to identify faults and maintain seat-belts.
Parents, guardians, teachers via the school curriculum, and the media	<p>Getting messages across about the benefits of seat-belt wearing early in life is obviously desirable. This can be particularly beneficial as informed children can use their knowledge to influence their parents' behaviour. Once children have increased their knowledge and adopted good safe practice, they may well criticize parents or guardians when they exhibit poor safety behaviour themselves on the road (e.g. not fastening their seat-belts before driving off).</p> <p>While research on the effectiveness of road safety education in changing behaviour has been inconclusive, what has become clear is that educational approaches that concentrate only on teaching facts are unlikely to be successful. There has to be a comprehensive package containing several approaches. Lesson plans provided for teachers are a way of encouraging schools to educate their pupils on the benefits of seat-belt wearing. Appendix 6 shows an example of a lesson plan for use in secondary schools.</p> <p>Stakeholders should also ensure that adequate information is provided to parents on the dangers of using an inappropriate restraint for children.</p>
Driver training schools	Include information on seat-belt use in their curriculum. Instruction should include information on laws pertaining to seat-belts and child restraints, penalties for non-use and the social and economic benefits of properly using seat-belts and child restraints.

A number of case studies are presented below to show examples of educational approaches in different countries with information about their impact, if available.



**CASE STUDY: Education and discount schemes for infant restraints, Greece**

A study of a maternity hospital-based infant restraint loan scheme in Greece found that 82% of parents who were provided with an infant restraint for six months for a small fee had purchased the next-level restraint by the time they returned the loaned one

(23). However, another study in Greece showed that the target group did not always take up the scheme, particularly in disadvantaged areas where the need was greatest (24).



**CASE STUDY: Educational leaflet, India**

The information leaflet shown below, distributed in India, concentrates on educating vehicle occupants of the importance of wearing a seat-belt. While many leaflets highlight the law regarding wearing, it is just as important to explain why one should wear a seat-belt. Here, the vehicle occupant is informed of the substantial forces involved in a 50 km/h crash due to severe deceleration of the vehicle. It explains how a seat-belt can minimize the injury sustained by a vehicle occupant if they are wearing a seat-belt.

It also uses pictures (top right) to demonstrate how to fit a seat-belt. Vehicle occupants should push the lap part of the seat-belt down onto their hips so

that it does not ride onto the abdomen. They should then pull the diagonal section up to minimize slack. "The diagonal section must stretch from the anchorage point over the centre of the occupant's shoulder avoiding contact with the neck."

**If you are involved in an accident at 30mph your body weight increases by approximately 25 to 30 times. Therefore, if you weigh 140lbs/10stones, in a 30mph accident you will weigh between 3500lbs/250st. and 4200lbs/300st. - the weight of an ELEPHANT!**

**YOU**

As a result of the very fast de-acceleration of the vehicle, the energy transfers from the car to the occupants. This means that the initial speed of each occupant is that which the vehicle was travelling on impact. In this case all occupants would travel forward at an initial speed of 30mph.

This force/weight travelling at this speed would need a serious device to reduce and minimise serious injury and/or potential death. Luckily we have one. It is called the SEAT BELT! Seat belts can reduce the severity of injury by four fifths compared to the severity of injury if you are not wearing your seat belt in an identical accident.

Your seat belt is designed to stretch, it is **ELASTIC**. This allows it to restrain your body over a short distance and time. This is necessary because if it stopped you instantly, it could cause serious injury. For example, throw an egg into the air and catch it without smashing it. To avoid breaking it we cushion the egg by lowering our hands, slowly reducing its speed over a few inches. If your hands stayed firm stopping the egg instantly you would now be clearing up the mess. If your seat belt stopped you instantly, you could have a similar problem to the egg.

If involved in an accident (even a minor accident), all seat belts used should be replaced. **WHY?** After cushioning the force from car occupants in an accident, the seat belt could have stretched too much. It then becomes plastic. This means that instead of cushioning your body next time you have an accident, it will act more like a band of steel. The result is similar to being stopped instantly as described above. Also the webbing has been weakened and may snap when you need it most.

Do not replace with second hand seat belts that you do not know the full history of. The consequences could be catastrophic.

Ensure that your seat belt, either Lap or Lap and diagonal, is in the correct position.

Push the lap belt underneath any thick clothing and down onto the hips so that it does not come across the abdomen. Pull tight to eliminate slack.

The diagonal belt must stretch from the anchorage point over the centre of the occupants shoulder avoiding contact with the neck. Height adjusters can be used to avoid such contact especially with young people.

All seat belts are subject to MOT testing. They will fail if:

- They are frayed from wear and tear
- There is a cut or nick causing fibres to separate
- There is damage to the buckle
- There is a weak connection to the vehicle
- There is a hole in the webbing regardless of size



### CASE STUDY: **Educational approaches to increase knowledge of the benefits of seat-belt wearing**

The pictures below show devices that have been used to educate vehicle occupants on the benefits of wearing a seat-belt by allowing participants to experience a simulated minor crash (5 km/h). Pictured below is the “seat-belt convincer”, used by the Japan Automobile Federation. This has helped to raise seat-belt use from 62% to 84% in Japan during the last decade (Japan Automobile Federation).



Pictured above is a seat-belt sled, a device that can be used to convince vehicle occupants of the need to wear a seat-belt before the introduction of legislation. It is an ideal publicity tool for the involvement of celebrities and politicians (FIA Foundation).



### CASE STUDY: **Increasing seat-belt and restraint use by children, United Kingdom**

In Manchester, United Kingdom, a campaign where police targeted schools to promote wearing of seat-belts and child restraints resulted in a rise of 20% in use of seat-belts. A campaign in Ireland in primary schools raised seat-belt awareness by a scheme that encouraged children in the first and second years of school to take the “seat-belt sheriff pledge”, by which they promise to tell all car occupants to buckle up

before driving. The campaign also included a road safety competition.

Alongside formal education in schools, peer education is also often effective. One study, using children as educators of their peers, found that persuasive arguments given by older children can significantly influence the behaviour of younger children (25).

#### **4.7.3 Insurance and public incentive schemes**

The motor insurance industry has the opportunity to play a key role in increasing road safety within a country. For example, motor insurance companies can encourage the wearing of seat-belts by making it clear in the wording of their policies that crash compensation can be reduced significantly if it is established that a vehicle occupant was not wearing a seat-belt at the time of a crash. This can be applied to private and company policies. Insurance companies can also promote seat-belt wearing by

supporting advertising and publicity campaigns. The effectiveness of seat-belt clauses will be limited by how well the insurance system is working, the extent of standard cover and compensation provided for victims of crashes, and how well insurance clients are informed about the clause.

**NOTE****Reduced compensation due to non-use of seat-belts**

In the United Kingdom, the level of personal injury claims has reduced since the recognition by the courts of “contributory negligence” by the injured party’s failure to wear a seat-belt. In *Froom vs. Butcher* (1975) it was shown that the claimant’s injuries would have been reduced by 25% had they been wearing a seat-belt, and as such their compensation was reduced by 15%. *Hitchens vs. Berkshire CC* (2000) set a precedent by reducing the claimant’s compensation by 50% after it was found that they were not wearing a seat-belt.

## **4.8 How to ensure an appropriate post-crash response**

While the primary aim of a seat-belt programme will be to increase seat-belt use, it is also important for those planning the programme to consider the response provided in the event of a crash (whether or not a seat-belt is worn by the vehicle user). A quick and appropriate rescue and medical response to the victim of a crash may prevent a fatality, or reduce the severity of the injury suffered. Thus, those designing a programme may want to consider both the appropriate rescue and first-aid response that is likely to be given at the scene of the crash and the preparedness of the formal medical services that will deal with victims of motor vehicle crashes.

Being involved in a crash can result in life-threatening injuries, including severe wounds to the head, chest and limbs that might also lead to unconsciousness and heavy blood loss. Following a crash, skilled rescue from the vehicle and provision of first aid and immediate acute care can make the difference between the crash victim’s survival or death, and can help reduce the consequences of injuries (see Box 4.8). Immediate on-the-scene assistance is of major importance, especially if the emergency services are absent or delayed, and can be encouraged in various ways.

Laws and regulations should be introduced promoting good-quality first aid, including the following:

- a law removing the threat of litigation against those giving first aid. Many countries provide legal immunity from charges of negligence against a bystander attempting, in good faith, to help a victim (“good Samaritan law”);

- the mandatory inclusion of first-aid knowledge, skills and a simple understanding of scene safety in the requirements for obtaining a driving licence or certificate;
- a requirement for vehicles to carry a first-aid kit;
- an incentive for manufacturers or sales people of vehicles to also provide a first-aid kit, or to support the participation of the buyer in a first-aid training course.

#### BOX 4.8: Ensuring that the emergency medical services are prepared

Setting up an emergency medical services (EMS) system may not be feasible for many countries, but alternative pre-hospital care arrangements can be developed.

The primary prevention of any disease or injury is an overriding priority. Many lives can also be saved following an injury through proper trauma care. This is especially the case in developing countries, where there are high fatality rates from potentially non-life-threatening injuries.

Trauma care, in both pre-hospital and hospital settings, requires speedy and appropriate action by trained personnel, with proper supplies and equipment. Improving trauma systems has been shown to lower the mortality rate in all treated trauma patients by between 15% and 20% and to cut the number of preventable deaths by over 50%.

Several recent publications provide technical details on how to improve trauma care. Two published by WHO are strongly recommended: *Guidelines for essential trauma care* (26) and *Pre-hospital trauma care systems* (27).

##### Pre-hospital care

The pre-hospital stage is an important one to target in efforts to cut the number of road traffic deaths. The care given will depend on the services that exist.

##### Situations where no formal EMS exists

A “formal” system of EMS is usually one with ambulances and trained personnel who work in an agency with some supervision and with a network of communications. Where no formal EMS exists, governments should make alternative arrangements to provide pre-hospital care. Ways can be found to build on existing informal systems and harness community resources, such as training members of the public in basic first aid, scene safety and simple rescue techniques. Setting up formal EMS systems in urban areas and along major interurban roadways should also be explored. Cost should be a consideration, given the high cost of these systems.

##### Strengthening existing intervention systems: EMS systems and rescue

Many EMS systems could be strengthened in a number of ways, for example by establishing a regulatory agency to promote minimum standards for the delivery of prompt, high-quality and equitable pre-hospital care; by streamlining communication between sites where calls are received (such as alarm centres) and the sites of ambulance dispatch, as well as between different ambulance services; and by keeping good records on people cared for by the EMS, so as to monitor and improve the quality of care.

##### Essential trauma care

Improvements in trauma care need not necessarily involve high-cost, high-technology equipment. Much can be accomplished in an affordable and sustainable way through better planning and organization.

The essential trauma care services and the resources required for them can be promoted in several ways, including through needs assessments of trauma care requirements; training in trauma care, provided in appropriate educational settings; quality improvement programmes that consider the entire trauma facility setting; and the inspection of trauma facilities (27).

##### Rehabilitation

Many of those who survive injury face disabilities that limit their physical functions. Many of these consequences are avoidable and can be reduced by improving rehabilitation services. Rehabilitation services are an essential element of trauma care, and can be improved by conducting more in-depth needs assessments for injury-related rehabilitation, by strengthening the capabilities of national rehabilitation programmes, and by integrating the recommendations of World Health Assembly Resolution WHA58.23 and the recommendations on rehabilitation in the *Guidelines for essential trauma care* (26) into a country's health policy.



### 4.8.1 Seat-belts and injuries

Seat-belts and child restraints may produce injuries. Although a seat-belt holds the body in place on the seat, it cannot prevent the head from being thrown around during a collision. Emergency personnel should be aware that a belted occupant could have sustained a neck injury and manage them accordingly.

The place where the seat-belt makes contact with the body during a collision may also result in minor injuries such as bruising (“the seat-belt sign”) or more serious problems such as broken ribs. However, it is highly probable that the injuries that the belted occupant would have sustained had they been unbelted would have been much more severe.

Children who are restrained in the rear of a vehicle with two-point lap belts can, under certain circumstances, sustain abdominal or lumbar spine injuries during a collisions – the so called “seat-belt syndrome”. Although most new vehicles are now equipped with three-point lap and diagonal seat-belts in all seating positions to prevent this problem, it is important that emergency personnel recognize incidents where occupants have used lap belts (mechanisms of injury).

### 4.8.2 Seat-belt removal

Following a collision it is important to remove the seat-belt from around a casualty as soon as possible. By doing so, rescuers will help to protect the casualty from receiving secondary injuries and to prepare the casualty for removal. Prompt removal of the seat-belt will help:

- eliminate restrictions to breathing or circulation;
- protect victims from further injury due to accidental activation of seat-belt pretensioners;
- allow safe movement of the casualty during cutting or spreading operations in the vicinity of seat-belt anchor points.

In addition, by removing the seat-belt, emergency personnel are reducing constraints placed on the casualty, which in turn enables them to remove casualties quickly if their condition deteriorates.

There are however times when the seat-belt must not be removed until the casualty is supported. These include where the casualty is suspended by the seat-belt in incidents where the vehicle has come to rest on its roof or its side (see related notes).

**NOTE**

**Vehicle on its side**

At incidents where the casualty is on the side of the vehicle that is nearest to the ground suspension by seat-belts is less likely to occur, and therefore in these circumstances seat-belts can be removed or cut. Where the casualty is on the upper side of the vehicle and suspended by the seat-belt then specific actions must be considered. Once the vehicle has been stabilized and it is safe to do so casualty carers should enter the vehicle to treat and support the casualty. The easiest method to effect a safe rescue from this type of incident is to fold down the vehicles roof. It is essential when carrying out this operation that the upper seat-belt anchor points are taken into consideration, and that they are not affected by cutting or spreading operations.

**NOTE**

**Vehicle on its roof**

Where a casualty is suspended by the seat-belt in an overturned vehicle, the consideration here is to create as much space within the vehicle by opening or removing doors and winding front seatbacks up. By doing so a greater amount of space will be created inside the vehicle to allow as many carers and rescuers as possible around the casualty to allow support and then a controlled lower following release or cutting of the seat-belt.

**BOX 4.9: Seat-belt removal**

As soon as possible arrangements should be made to release or remove the seat-belt.

The easiest method is to unclip the seat-belt from the anchor point. Persons assisting with this must ensure that the casualty is not being supported by the seat-belt. They must also ensure that they do not put themselves at risk by placing themselves within the deployment path of any airbags that are present.

Once the seat-belt has been unclipped, totally remove it from the casualty and place it out of the way to prevent trip/snagging hazards.



Where there is a need to cut the seat belt, again ensure that the casualty is not being supported by the seat belt.

The easiest method is to cut the belt in two places, in the centre of the diagonal and on the lap belt portion. By doing so this will prevent unnecessary pulling and tugging of the belt against the casualty as it is removed.

First support the casualty by hand and cut the diagonal portion of the belt as shown. It is best to use a safety seat-belt cutter where possible.



Once the diagonal is cut, the lap portion of the seat-belt should now be cut, again using a safety seat-belt cutter.

Once both cuts are complete totally remove remaining belt portions from the casualty and place out of the way to prevent trip/snagging hazards.

*Note:* On all occasions where seat-belts have been removed this information must be passed to both medical personnel, to assist with identifying mechanisms of injury, and police personnel, to confirm adherence to local laws.

## **Summary**

This module provides an overview of the steps necessary to design an effective programme aimed at increasing seat-belt use, in turn decreasing serious injuries and fatalities amongst drivers and passengers. As stressed throughout the module, an effective programme depends on a combined approach using legislation, standards, education and enforcement.

Appropriate legislation is an important step to increasing seat-belt use. An initial assessment of the current legislative situation will help decide whether a new law is needed or if a revision to an existing law would be sufficient. It is important to identify how, when and where the new law will be implemented. Legislation should be promoted by the highest levels of government to ensure that it has the support of enforcement agencies and a proper legitimacy among the public.

Standards for seat-belts should be developed to ensure access to quality safety equipment. Standards – of design and materials used – should be set so as to give vehicle occupants a high level of protection in the event of a crash.

The fact remains that any standard adopted to increase the safety of vehicle occupants is better than none. However, in order to provide consistency and a coordinated approach to raising the standard of seat-belts, it is recommended that countries adopt the uniform technical prescriptions outlined by the World Forum for Harmonization of Vehicle Regulations.

A system should also be implemented that ensures regular independent testing, assessing wear and damage of seat-belts and their components using pass and fail criteria. Guidance should be provided to both vehicle owners and vehicle inspectors on assessing wear and damage of seat-belts.

To aid the process of encouraging vehicle occupants to wear seat-belts, organizations should be convinced of the need to play a proactive role in the installation of seat-belts in fleet vehicles. This will result in an improvement in road safety overall whilst achieving health and safety objectives.

Both voluntary and mandatory measures can be used to increase compliance with a seat-belt law. Indeed, continuous and fair enforcement of the law is essential for raising rates to a significant level. This calls for a strong commitment from both the government and the enforcement agency. Existing enforcement agencies should be evaluated to see if their capacities need to be increased. A plan for penalizing motorists who break the law on seat-belt use should be devised. Penalties can take the form of warnings, fines or the suspension of licences.

Together with legislation and enforcement, a well-designed marketing and publicity campaign is essential for the success of a seat-belt use programme. To meet these objectives, a good marketing or advertising agency may need to be taken on to

create an effective communication campaign. Communication should be aimed at motorists not using seat-belts, as well as at a secondary audience with the potential to influence non-users. The messages should be simple, consistent and memorable, and appropriate to the social and cultural standards of a particular country.

There is an important role for public education, school education and peer education among young people. Educational programmes, combined with other activities, can help shift behavioural norms towards making seat-belt use more acceptable.

When designing a seat-belt use programme, practitioners should consider the post-crash response to crash injuries. This involves addressing the appropriateness of first-aid services, and examining the capacity for provision of pre-hospital care, essential trauma care and rehabilitation services to assist crash victims.

Table 4.10 summarizes the main steps in the process of implementing a seat-belt programme.

**Table 4.10 Checklist for designing and implementing a seat-belt programme**

Step	Components
Implementing overall seat-belt wearing programme	<ul style="list-style-type: none"> <li>• Assessment of seat-belt use</li> <li>• Identification of problem</li> <li>• Selection of objectives</li> <li>• Selection of corresponding activities</li> </ul>
Developing legislation, creating a penalty system, and developing or improving standards	<ul style="list-style-type: none"> <li>• Consideration of institutional or cultural constraints</li> <li>• Selection of objectives</li> <li>• Drafting of legislation</li> <li>• Creating a penalty system</li> <li>• Approval of legislation</li> <li>• Implementation of legislation</li> </ul>
Developing an enforcement strategy	<ul style="list-style-type: none"> <li>• Assessment of capacity to enforce</li> <li>• Increasing policy capacity if necessary</li> <li>• Training police in enforcement</li> </ul>
Increasing the voluntary use of seat-belts by the public	<ul style="list-style-type: none"> <li>• Develop and implement a publicity campaign:               <ul style="list-style-type: none"> <li>– Set the objectives, targets and performance indicators for the campaign</li> <li>– Select an agency for the campaign</li> <li>– Create campaign messages and select the creative concept that will reach the target audience</li> <li>– Consider how to best incorporate and work with the media</li> <li>– Map out campaign stages in relation to seat-belt legislation and strengthened enforcement by the police</li> <li>– Carry out and evaluate the campaign</li> </ul> </li> <li>• Consider developing and encouraging other voluntary approaches, including:               <ul style="list-style-type: none"> <li>– Engaging employers in increasing seat-belt usage among staff and contractors through employee regulation and incentive schemes</li> <li>– Implementing public education and training programmes to reach diverse segments of the public, such as children and new drivers</li> <li>– Engaging the insurance sector in proactive schemes to encourage seat-belt usage</li> </ul> </li> </ul>
Ensuring appropriate response at and after scene of the crash	<ul style="list-style-type: none"> <li>• Encourage appropriate first aid to victims of crashes through legal framework and delivery of first-aid education programmes</li> <li>• Consider the pre-hospital care, essential trauma care and rehabilitation services that are required and existing capacity to respond to these needs</li> <li>• Train and equip rescuers to ensure the prompt and safe removal of victims unable to remove their seat-belts</li> </ul>

## References

1. Broughton J. *Restraint use by car occupants, 1982–1989*. Research Report 289. Crowthorne, United Kingdom, TRL Ltd, 1990.
2. Lonero L, Clinton K, Sleet DA. Behavior change interventions in road safety. In: Gielen AC, Sleet DA, DiClemente R, eds. *Injury and violence prevention: behavior change theories, methods and applications*. San Francisco, California, Jossey-Bass, 2006:213–233.
3. *Promoting seat belt use*. ETSC Fact Sheet number 12, April 2006 ([http://www.etsc.be/documents/Fact\\_Sheet\\_Seat\\_Belt\\_Use\\_2006.pdf](http://www.etsc.be/documents/Fact_Sheet_Seat_Belt_Use_2006.pdf), accessed 14 November 2008). Updated data provided by l'Observatoire national interministériel de sécurité routière, 2008.
4. *Seat belt campaign toolkit*. London, FIA Foundation, May 2004 (<http://www.fiafoundation.org/news/archive/2004/Pages/Seatbeltcampaigntoolkit.aspx>, accessed 20 October 2008).
5. Pinder M. Changes made to seat belt law. *Bahama Journal*, 15 March 2007.
6. *Agreement concerning the adoption of uniform technical prescriptions for wheeled vehicles, equipment and parts which can be fitted and/or be used on wheeled vehicles and the conditions for reciprocal recognition of approvals granted on the basis of these prescriptions*. Revision 2. Geneva, United Nations Economic Commission for Europe, Inland Transport Committee, 1995 (<http://www.unece.org/trans/main/wp29/wp29regs.html>, accessed 14 November 2008).
7. *UNECE Regulation 14, Revision 2: safety-belt anchorages*. Geneva, United Nations, 1970 ([www.unece.org/trans/main/wp29/wp29regs1-20.html](http://www.unece.org/trans/main/wp29/wp29regs1-20.html), accessed 4 November 2008).
8. *UNECE Regulation 16, Revision 4: safety-belts and restraint systems*. Geneva, United Nations, 1970 ([www.unece.org/trans/main/wp29/wp29regs1-20.html](http://www.unece.org/trans/main/wp29/wp29regs1-20.html), accessed 4 November 2008).
9. *UNECE Regulation 44, Revision 1: restraining devices for child occupants of power driven vehicles (child restraint system)*. Geneva, United Nations, 1981 ([www.unece.org/trans/main/wp29/wp29regs41-60.html](http://www.unece.org/trans/main/wp29/wp29regs41-60.html), accessed 4 November 2008).
10. *Recommendations for anchoring of seat belt assemblies*. Appendix ZD of AS/NZS 2596:2003.
11. *Compliance cost assessment: seat belts in coaches and minibuses*. London, United Kingdom, Department for Transport, 1994.
12. Bylund P-O, Björnstig U. *Use of seat-belts in cars with different seat-belt reminder systems: a study of injured car drivers*. AAAM 45th Annual Conference, 24–26 September 2001.
13. Williams AF et al. Buckle up now! An enforcement program to achieve high belt use. *Journal of Safety Research*. 2000, 31(4).
14. *Primary enforcement saves lives: the case for upgrading secondary safety belt laws*. National Highway Traffic Safety Administration, 2006 (<http://www.nhtsa.dot.gov/people/injury/enforce/PrimaryEnforcement/index.htm>, accessed 14 November 2008).
15. Van Rooyen P. *Principles of social marketing: the Saatchi worldwide experience*. Marketing Traffic Safety: VIth World Congress of the International Road Safety Organization, 3–6 October 1994, Cape Town, South Africa.
16. Silveira AJ. *Seat-belt use in Buenos Aires, Argentina: a 14-year-old struggle*. Luchemos por la Vida. Paper presented at the International Conference on Traffic Safety on Four Continents, Warsaw, October 2005.
17. *Polish seat belt campaign*. Krajowa Rada Bezpieczeństwa Rucha Drogowego, 2006.
18. Donovan RJ, Jalleh G, Henley N. *Effective road safety advertising*. Nedlands, Australia, Road Accident Prevention Research Unit, 1996.

19. *Seat belt campaign*. Global Road Safety Partnership and Sakhalin Energy Investment Company Ltd, 2007 (<http://www.grsproadsafety.org/?pageid=321&projectid=61#61>, accessed 4 November 2008).
20. Tarawneh MS, Al-Balbissi AH, Tarawneh TM. The effectiveness on seat belt use in Jordan of a public education campaign. *Journal of Traffic Medicine*, 2001, 29(3-4):30-36.
21. Department for Transport, London, United Kingdom ([www.dft.gov.uk](http://www.dft.gov.uk), accessed 4 November 2008).
22. Milne PW. *Fitting and wearing of seat belts in Australia: the history of a successful countermeasure*. Canberra, Australia, Australian Government Publishing Service, 1985.
23. Kedikoglou S et al. A maternity hospital-based infant car-restraint loan scheme: public health and economic evaluation of an intervention for the reduction of road traffic injuries. *Scandinavian Journal of Public Health*, 2005, 33(1):42-49.
24. Dedoukou X et al. Evaluation of an infant car restraints loan scheme in Athens, Greece. In: *Conference proceedings. What works in child injury prevention: bridging the gap between research and practice*. Sintra, Portugal, 10-12 October, 2002.
25. Morrongiello B, Bradley MDM. Sibling power: influence of older siblings' persuasive appeals on younger siblings' judgements about risk taking behaviours. *Injury Prevention*, 1997, 3:23-28.
26. Mock CN et al. *Guidelines for essential trauma care*. Geneva, World Health Organization, 2002.
27. Sasser S et al. *Pre-hospital trauma care systems*. Geneva, World Health Organization, 2005.





# 5

**How to evaluate  
the programme**

<b>5.1 Planning the evaluation</b> .....	145
5.1.1 Aims of evaluation .....	146
5.1.2 Types of evaluation .....	147
<b>5.2 Choosing the evaluation methods</b> .....	151
5.2.1 Study types for formative and process evaluations .....	151
5.2.2 Study types for impact and outcome evaluations .....	151
5.2.3 Choosing the performance indicators .....	156
5.2.4 Conducting an economic evaluation of a programme .....	157
5.2.5 Determining sample size .....	158
<b>5.3 Dissemination and feedback</b> .....	159
5.3.1 Checklist for evaluation process .....	159
5.3.2 Using evaluation results to feed back into new planning cycle. . . .	159
<b>Summary</b> .....	160
<b>References</b> .....	160

**M**ONITORING AND evaluation of any programme or intervention is vital to determine whether it works, to help refine programme delivery and to provide evidence for continuing support of the programme. Evaluation will not only provide feedback on the effectiveness of a programme but will also help to determine whether the programme is appropriate for the target population, whether there are any problems with its implementation and support and whether there are any ongoing concerns that need to be resolved as the programme is implemented.

This module describes the process of developing and conducting an evaluation of a seat-belt programme. It is divided into three key sections:

**5.1 Planning the evaluation.** This important initial section describes how to define the aims of an evaluation, and details the various forms evaluation may take (process, impact and outcome).

**5.2 Choosing the evaluation methods.** Once the type of evaluation has been determined, there are different methods that can be applied to carry out an evaluation. This section describes the different study types possible, explaining the advantages and disadvantages of each type of method. It outlines the types of performance indicators that can be used to measure the success of a programme. This section also briefly describes how to conduct an economic evaluation, and provides guidance on calculating sample size.

**5.3 Dissemination and feedback.** This section describes how to feed the result of an evaluation back into the planning and implementation stages, and ways that the results of an evaluation can be shared with different interested parties.

## **5.1 Planning the evaluation**

The process of designing and implementing a seat-belt or child restraint programme was covered in Module 4. Work carried out prior to implementation should ensure that the programme is clearly defined and that it is implemented in a consistent and standardized way. It is far easier to evaluate the impact of a complete, well-planned and executed programme than one that is implemented in an inconsistent way.

It is essential that the evaluation framework is developed and implemented alongside the proposed programme. Thus, this work would be carried out by the working group as they develop the action plan for the programme (see Module 3). For most forms of evaluation, baseline measures need to be collected **before** the intervention is put in place so that change in such measures over time may be gauged. It is therefore important that the evaluation framework is well established early on.

The type of evaluation to be conducted will depend on a number of factors. These include the aims of the evaluation itself and the objectives of the programme being evaluated. The type of methodology chosen may also depend on resource constraints.

### 5.1.1 Aims of evaluation

Establishing the aims of the evaluation will help to determine how best to carry out the evaluation. The evaluation may have one or more aims. For example, an evaluation of seat-belt legislation and an increased enforcement programme may primarily be aimed at determining whether seat-belt wearing rates have gone up as a result of the programme. Secondary aims may include determining whether the enforcement has increased, whether training of police is effective and whether the programme is acceptable to the stakeholders. The evaluation in this case needs to be multifaceted.

The breadth of an evaluation will always be limited by the resources available, and a well-designed simple evaluation can be as powerful as a more complex one.

If the objective is to increase the provision of seat-belts fitted in vehicles, stakeholders may wish to assess:

- the number and type of vehicles with seat-belts installed;
- the number and type of vehicle manufacturers fitting seat-belts as standard;
- the number and type of imported vehicles sold in the country with seat-belts installed;
- seat-belt sales for retrospective fitting;
- the number and type of vehicles retrospectively fitted at approved test centres;
- seat-belt standards and legislation (implemented and enforced).

If evaluation of a specific discipline is required, for example publicity, then questions must be asked that are specific to that element of the campaign. For instance, if a seat-belt cinema advertising campaign has been implemented aimed at vehicle users aged 17–24 years, it is important that evaluation of success for this element is not clouded by data regarding all vehicle occupants. Therefore stakeholders may wish to assess using the following data:

- baseline wearing rates for 17–24-year-olds;
- the number of 17–24-year-olds attending the cinema where advertising is shown;
- surveys of 17–24-year-olds' opinions and awareness prior to viewing advertising;
- surveys of 17–24-year-olds' opinions and awareness after viewing advertising;
- national and local wearing rates for 17–24-year-olds;
- crash and injury severity data for 17–24-year-olds.

### 5.1.2 Types of evaluation

Evaluation may take several forms, and one or more may be appropriate, depending on the aims of the specific programme to be evaluated (1).

#### Process evaluation

Rather than measuring change in outcomes, process evaluation examines whether the programme was carried out as planned. This involves creating a list of indicators that need to be measured, depending on the aims of the programme. The results will help to identify the strengths and weaknesses of the programme, and where improvements may be made.

For example, in a media campaign designed to increase voluntary use of seat-belts and child restraints, a process evaluation may ask these sorts of questions:

- Have the campaign products (posters, billboards, radio and television spots) been pre-tested?
- How often were the campaign advertisements run?
- How many people saw them?
- Was the target group being reached?
- Are high-quality child restraints available in local shops?

If the intervention involves enforcement of seat-belt legislation:

- Is there noticeable enforcement by police?
- Are the police supportive of the campaign?
- Is the penalty sufficient to change behaviour?
- Are people able to circumvent the process (for example, using bribery)?

Process evaluations are “formative”; that is, the enquiries carried out are designed to provide information to guide programme improvement (2). For example, it may be considered important to determine whether the television advertisements shown as part of a seat-belt programme are appropriate – do they adequately address the issue, do they give the right information about how to choose child restraints?

#### Impact assessment

An impact assessment will determine whether the advertisements have brought about a change. The impact, or programme effect, refers to whether the programme has made an impact on the target population (2). For example, if the seat-belt programme involved airing television advertisements on seat-belt use, the impact assessment might examine whether people who had seen the advertisements believed that there was a good chance that they would be fined by the police if they did not wear a seat-belt.



### CASE STUDY: **Evaluation of rear seat-belt campaign, United Kingdom**

A new campaign to raise awareness of the need to wear seat-belts in the rear of cars was launched by the Department for Transport in July 1998. Research among the target audience had indicated that most were not aware that an unbelted rear seat passenger could kill the driver in the event of a crash. The campaign focused on this fact (3).

Monthly tracking research monitored the impact of the campaign in terms of awareness, understanding and attitudes to particular road safety behaviours. Observational, evidential and accident data were also collected to give a longer-term measure of campaign impact.

Independent survey work commissioned by the department before and after the campaign indicated significant attitudinal changes. For example, there was a substantial increase in the numbers recognizing that, in a crash, a rear seat passenger not wearing a seat-belt could injure or kill the driver or front seat passenger. Research among 2000 adults showed

significant shifts in awareness of the seat-belt wearing message. Recognition that an unbelted rear seat passenger might kill the driver in the event of a crash rose from 33% to 53% among 16–24-year-olds.

The week-long campaign ran in July 1998 and was effective not only in raising awareness but also in affecting seat-belt wearing behaviour. It is almost certain that many drivers who took note of the advertising were asking passengers to belt up.

Observational research is carried out each April and October by the Transport Research Laboratory. In April 1998, three months before the campaign, the adult wearing rate in the rear was 48%. In October it was 54%. The advertising campaign has been run over occasional week-long bursts since then. The increasing understanding of what can happen has been accompanied by an improving trend in seat-belt wearing rates. In October 2006 the rate was 65%, following a new campaign aimed at young men (see also United Kingdom case study in section 4.6.7).

### **Outcome evaluation**

An outcome evaluation measures outcomes to see if the programme was successful. Are more people now wearing seat-belts than before? Have deaths and serious injuries been reduced? Are more children restrained in child restraints suitable for their age and size? Measuring a change in outcomes is probably the most common form of evaluation as it provides information as to whether the programme or intervention has actually made a difference (4).

The case study on the China Seat-Belt Intervention Project describes the evaluation of the seat-belt campaign in Guangzhou, China. This evaluation included a process evaluation assessing the changes in police enforcement practice, and an outcome evaluation in terms of the effect on seat-belt wearing rates. It also estimated the cost-effectiveness of the campaign.



## CASE STUDY: **Seat-Belt Intervention Project, China**

In China, injuries are the leading cause of death from age 1 to 44 years, accounting for approximately 750 000 deaths and 3.5 million hospitalizations each year. Much of the injury-related mortality and morbidity is due to road traffic injury, perhaps expectedly, given that motor vehicle production has tripled since the early 1990s. In the large urban centres such as Beijing, Shanghai and Guangzhou, where the burden of road traffic injuries is growing rapidly, there is an urgent need to implement proven road safety interventions. In the absence of widespread implementation of road safety interventions, the epidemic of road traffic injuries will worsen. The China Seat-Belt Intervention Project was an initiative proposed by the representative of WHO in China and developed by the George Institute for International Health. It involved cooperation between the Chinese Government, international organizations and industry. It was officially launched in Guangzhou in mid-2005. In this one province, almost 10 000 road traffic crashes took place during 2004, resulting in 1800 deaths and almost 12 000 people injuries.

In 1993, the Ministry of Public Security in China instituted a regulation requiring all vehicles less than 6 m in length to have seat-belts fitted for the front seats. Despite the availability of seat-belts in almost all cars (excluding trucks) in China and laws on the use of seat-belts, their use has not reached levels achieved in countries such as Australia, where seat-belt use is as high as 90%.

### **Aims**

The main purpose was to implement a comprehensive intervention over 12 months focused on increasing seat-belt use in Guangzhou, with the following specific aims:

- to increase the rate of correct seat-belt use by 20%;
- to estimate the cost-effectiveness of the intervention;
- to build capacity in road traffic injury prevention in Guangzhou.

### **Methods**

The evaluation of the intervention was undertaken by adopting a comparison group pre-test/post-test design. Two sites were selected, one that received

the intervention (Guangzhou City) and another that acted as a comparison site (Nanning City). Prior to the implementation of the intervention, extensive baseline (pre-test) measures of the key outcomes were undertaken. These measures were repeated 12 months post-intervention (October 2006).

An economic evaluation was undertaken to determine the cost-effectiveness of the intervention. The reason for conducting an economic analysis was to ensure that injury prevention resources were being allocated to programmes that represented value for money.

### **Status and results**

In order to explore the barriers to seat-belt use amongst drivers and front seat passengers, a number of focus groups were hosted in Guangzhou City. A survey into seat-belt availability and seat-belt quality was conducted in November 2004.

A successful launch of the intervention was held on 25 April 2005 at Times Square in Guangzhou City. Representatives from the Ministry of Public Security, the Ministry of Health and provincial government, as well as representatives from WHO and the project funder, BP China, attended the launch.

From 20 to 24 June 2005, 50 senior traffic police officers received skills-based training and were educated on strategies for enforcement by Mr Ray Shuey, the former Assistant Commissioner of Police in Australia. Training for all police officers was conducted across all the branches of Guangzhou Traffic Command and Control Centre (TCCC) between August and October 2005, with 1125 traffic police (82.6%) in Guangzhou trained in enhanced enforcement practices targeting the enforcement of seat-belt use.

Throughout the month of September 2005, the Division for Safety and Education of TCCC conducted a comprehensive educational programme for taxi companies in Guangzhou, aiming to raise the prevalence of seat-belt use among taxi drivers.

Five intensive law enforcement activities aimed at promoting seat-belt use, linked with a social marketing campaign, were conducted between October 2005 and August 2006. Each traffic police branch in Guangzhou established two checkpoints within its precincts. Target locations included locations

*Continues...*

*Continued from previous page*

with high crash risk, the train station, the airport and tollgates. Traffic police officers who had attended the train-the-trainer course were appointed to oversee the enforcement. Normal routine enforcement was still applied when specific campaigns were not in operation. During the study period, several approaches included in the training were implemented by TCCC to encourage traffic police officers to continue enforcing the use of seat-belts and penalizing infringers.

As described above, comprehensive social marketing campaigns linked with intensive enforcement were implemented. Related information was published on the traffic management web site; stickers and brochures were distributed among drivers; posters were displayed in a number of parking lots and taxi company premises; bus advertisements delivering the key message “Seat-belts save lives” were displayed on 15 buses along three bus routes that ran through the city centre; the intervention advertising was released in two major newspapers, featured on Guangzhou CATV six to seven times per day and broadcast on Guangzhou Radio traffic channel (FM 106.1) 18 times per day. The highly popular television commercial for the intervention, developed by collaborators and the Chinese Export Commodities Fair Advertising Co. Ltd, won a bronze prize at the 13th Guangdong Advertising Collection in 2006.

The post-intervention observations were collected in late 2006 and statistical analysis of results was completed in early 2007. The results showed that following the 12-month intervention period, the prevalence of seat-belt use increased significantly, from a prevalence of 50% (range 30–62%) to a prevalence of 62% (range 60–67%) in the intervention city. In contrast, the prevalence of seat-belt use declined, significantly, in the comparison city; an overall

difference between the increased prevalence in the intervention city and decline in the comparison city of 18%. Importantly, the prevalence of seat-belt use increased significantly ( $P < 0.01$ ) from pre- to post-intervention in the intervention city across all factors, namely seat-belt use by male or female drivers, both drivers and front seat passengers, and across road types and vehicle types. The greatest increase in the prevalence of seat-belt use was among drivers and passengers of taxis in the intervention city. The prevalence of seat-belt use among taxi drivers increased by 21% ( $P < 0.01$ ) (from pre-test 30%, range 10–58%, to post-test 51%, range 45–60%). In contrast, the prevalence of seat-belt use significantly declined ( $P < 0.01$ ) in the comparison city over the observational period across the same factors.

Based on the increased prevalence of seat-belt use observed as part of the intervention, the estimated total number of disability-adjusted life years (DALYs) saved as a result of the intervention was 530. Taking account of the cost of implementing the intervention (US\$ 221 500), along with the associated cost savings, the incremental cost–effectiveness ratio of the intervention compared with no enhanced programme to increase the

prevalence of seat-belt use was 3246 Chinese yuan per DALY saved (or the equivalent of US\$ 418 per DALY saved).

The intervention provided the government with the opportunity to build capacity in road safety and, at the same time, provided information on the opportunity to target financial resources in order to reduce the burden of road traffic injury. Importantly, the study provided outcomes such as changes to police enforcement practice and comprehensive road safety communication strategies that are a legacy of the project and will be invaluable to both central and provincial-level governments who are responsible for road safety in China (5).





## 5.2 Choosing the evaluation methods

The methods used for each type of evaluation will vary. Both qualitative and quantitative methods can be used within the design of an evaluation. Qualitative methods may be employed for the formative or process evaluations, for example focus groups and use of short-answer or open-ended questionnaires (6).

Impact and outcome evaluations may be carried out using a variety of quantitative methods. Using an experimental or quasi-experimental design to demonstrate a change (or not) is the most powerful programme evaluation for detecting changes in outcome. The type of methods used will depend on the aim of and the budget for the evaluation.

### 5.2.1 Study types for formative and process evaluations

Formative evaluation is often in the form of qualitative research, which tends to involve detailed verbal descriptions of characteristics, cases and settings to explain reasons underlying various behavioural patterns. Specific techniques include using focus groups, in-depth interviews or surveys with short answers or open-ended questions (7, 8). For example, a question in a formative evaluation of a media campaign aimed at increasing seat-belt use may be whether the television advertisements address the question. Focus groups may be set up to determine whether the audience believes that the message from the television advertisements is appropriate. Feedback will further enhance the development of the advertisement.



#### CASE STUDY: Evaluation of televised road safety messages, Ghana

Researchers in Ghana evaluated the effectiveness of televised road safety messages on speeding and alcohol-impaired driving (9). Focus groups were conducted with 50 commercial drivers and addressed coverage, clarity and appropriateness of messages, including suggestions for improvements. The advertisements reached and were understood by most

of the target audience, although some participants were unclear on the behaviour that the advertisements were urging viewers to take. Opportunities for strengthening the messages included using other media, increasing the number of languages used and stressing the change in behaviour being recommended.

### 5.2.2 Study types for impact and outcome evaluations

There is a well-defined hierarchy of study designs for examining the effectiveness of interventions. These range from randomized controlled trials, which provide a high level of evidence, to uncontrolled before–after studies, which provide very weak evidence about the effectiveness of an intervention.

### Randomized controlled trial

The gold standard of evaluation, the randomized controlled trial (RCT), will provide the highest-quality level of evidence of whether an intervention or programme is successful. For the RCT, individuals (or groups of individuals, for example a school or village, in a variant of the RCT known as a cluster randomized trial) are randomly allocated to either receive, or not receive, the programme. As participants (or groups of participants) are randomly assigned to one group or another, other factors that may influence the outcome – measured and unmeasured – are more likely to be balanced between the intervention and non-intervention groups. However, although RCT designs should always be considered when evaluating the effectiveness of an intervention, they do require significant resources and may be difficult to conduct with a limited budget. There may also be ethical considerations in randomizing an intervention with known benefits (that is, in denying an effective intervention to those participants who will be in the non-intervention group).

It is important to note that there is no need to conduct an RCT on the effectiveness of seat-belts themselves as part of the seat-belt programme. There is sufficient evidence from a number of studies that clearly demonstrates that seat-belts are effective at reducing the injuries and fatalities that result during motor vehicle crashes (see Module 1).



#### Examples of randomized controlled trials

Goodson, Buller & Goodson (10) carried out an RCT of prenatal safety education in two hospitals in the United States. Reported use of child safety seats was 96% for the intervention group and 78% for the control group.

Stuy (11) studied children aged 2–6 years and parents at childcare centres offered educational activities. In the intervention group children observed wearing seat-belts rose from 54% before to 75% after. For the control group the rise in seat-belt wearing rates was from 20% to 30%.

### Quasi-experimental designs

Quasi-experimental study designs, while not as rigorous as randomized trials, if well conducted, may also be used to establish the effectiveness of an intervention. Such designs may also involve a “treatment” and a “control” group, but individuals or communities are not randomized into these groups.

### Controlled before–after study

The controlled before–after study is often the most practical design for programme evaluation. Randomization is not always feasible, for example where some areas have already adopted an intervention. The controlled before–after study design involves observing the outcome of interest (for example seat-belt use rates) before and after the programme, in both the people who receive the programme and those in a control group. The control group should be as similar as possible to the programme group and any important differences between the groups need to be taken into account. Having a control group means that trends that may have been occurring in the population aside from what was happening due to the programme are taken into account (Box 5.1).

#### BOX 5.1: Evaluation using a controlled before–after study

A school-based intervention was developed in 1999 to increase seat-belt use among families living along the Texas-Mexico border, where child use of seat-belts had been found to be low. The Socorro Seatbelt Program sought to increase seat-belt use by changing perceived norms within the community, i.e. making the non-use of seat-belts less socially acceptable. Children in primary schools were shown reasons why family members should wear seat-belts, and reasons why they might not do so. Related activities included poster competitions and role model stories, and seat-belt newsletters were distributed to families. Parents were invited to join their children in a second poster and slogan competition.

Two adjacent communities served as the intervention and control sites. There were five schools in

the intervention community and six in the control community. The two communities were similar in terms of demographic characteristics.

Pre-intervention seat-belt use was observed at each primary school during a 13-day period. Post-intervention assessments were conducted exactly one year later. In the intervention community, seat-belt use among children increased from 47% to 57%, whilst in the control community seat-belt use among children showed a non-significant decline from 50% to 47%. Whilst there was no significant change in drivers' seat-belt wearing arriving at the intervention schools, at the control schools drivers' seat-belt wearing declined significantly from 90% to 83% (12).

### Before–after study (no control group)

The before–after study without a control group is often used to evaluate the impact of a programme, but provides the weakest evidence for the effectiveness of a programme. This design involves measuring the outcome of interest before and after the programme has been run. This study design is simple and may be conducted relatively cheaply, as all that is needed is a sampling frame and research assistants to conduct observations at various sites. However, without a control group the scientific merit of these study types is relatively limited, as it is often difficult to attribute with any certainty the change in outcome to the introduction of the programme.



### CASE STUDY: **Before–after study (no control group) to evaluate a seat-belt campaign, Queensland, Australia**

In 1972 it became compulsory for all vehicle occupants to wear seat-belts in Queensland, Australia. Queensland Transport implemented public education campaigns over several years, and in 1997 the Fatal 4 campaign was developed in conjunction with the Queensland Police Service. Research conducted by Queensland Transport in August/September 2000 showed that 10% of people admitted to driving without a seat-belt. The most frequently cited reason was “being on a short trip”. The campaign aimed to dispel popular myths:

- Seat-belts are only necessary on long journeys.
- Seat-belts cause injuries.
- It is not necessary to wear a seat-belt in the rear.

The campaign during 1998 to 2000 aimed to encourage motorists and passengers to buckle up by alerting them that police will enforce the wearing of seat-belts and reminding them of the penalties of non-compliance. The campaign included television and radio advertising, billboard and taxi messages, and a brochure aimed at visitors to the Olympics in 2000. Research showed that support for the statement “Since the ad I have made more of an effort to wear my seat-belt” increased significantly from 46% in April 1999 to 58% in August 2000. In 2001, research showed that only 5% of motorists admitted to driving without wearing a seat-belt. Of respondents, 64% claimed that they had seen some or all of the billboard messages, and 50% of motorists believed that the billboard messages strongly encouraged them to belt up (13).

### **Interrupted time series design**

It is possible to assess the effect of a programme by using multiple measures of the outcome of interest before and after the programme. There are a number of different variations on this design, some involving control groups. Studies that have used these designs generally use routinely collected measures, such as death rates, as multiple measures are required for appropriate analysis. This study design is, however, subject to time-related challenges to its validity, given the possibility that other factors occurring simultaneously to the programme actually led to the observed effect. Statistical analysis of such data can take into account any such secular trends, meaning that it is possible to establish whether the intervention or programme was responsible for the change in outcome.

Table 5.1 summarizes the characteristics and advantages and disadvantages of the study types discussed in this section. Further detail about study types is available in references 14 and 15. There is also a useful online glossary of research terms at <http://www.cochrane.org/resources/glossary.htm>.

**Table 5.1 Study types and their advantages and disadvantages**

	Formative, process evaluation?	Impact, outcome evaluation?	Advantages, disadvantages
<b>Qualitative</b>			
Focus groups/ in-depth interviews	<ul style="list-style-type: none"> <li>• Formative</li> <li>• Process</li> </ul>	<ul style="list-style-type: none"> <li>• Outcome</li> </ul>	<ul style="list-style-type: none"> <li>• Can provide information on why intervention may or may not have worked</li> <li>• Cheap</li> <li>• Sample (participants) is not random</li> <li>• Results are not generalizable</li> </ul>
<b>Quantitative</b>			
Randomized controlled trial		<ul style="list-style-type: none"> <li>• Impact</li> <li>• Outcome</li> </ul>	<ul style="list-style-type: none"> <li>• Most rigorous evidence</li> <li>• Expensive</li> <li>• Randomization not always feasible</li> </ul>
Controlled before–after study		<ul style="list-style-type: none"> <li>• Impact</li> <li>• Outcome</li> </ul>	<ul style="list-style-type: none"> <li>• Most practical design</li> <li>• Must have comparable control group</li> </ul>
Before–after study (no control group)		<ul style="list-style-type: none"> <li>• Impact</li> <li>• Outcome</li> </ul>	<ul style="list-style-type: none"> <li>• Cheap</li> <li>• Low level of evidence</li> </ul>
Interrupted time series design		<ul style="list-style-type: none"> <li>• Impact</li> <li>• Outcome</li> </ul>	<ul style="list-style-type: none"> <li>• Practical design if sufficient numbers of events and accurate surveillance systems in place</li> </ul>

**BOX 5.2: Effectiveness of programmes promoting use of child restraints**

A systematic review (16) identified 16 studies examining the effects of educational campaigns aimed at increasing the use of safety seats and seat-belts for children. A variety of approaches were used, with all studies including an element of professional counselling to encourage use of restraints (seat-belts etc.), supported by a range of media. Some programmes included rewards or coercion such as fines to encourage compliance. There is evidence that the campaigns led to an increase in observed restraint use, although this may not be sustained in the long term. This conclusion is supported by Grossman and Garcia (17), who report that the magnitude of positive effects from such programmes diminishes substantially one or more months after the intervention. More intensive programmes appear

to produce more positive results. There is some indication that programmes may be less effective for older children.

Two further reviews (18, 19) conclude that education alone has a modest effect in increasing use of child restraints. This can be considerably strengthened among younger children where appropriate restraints are provided through a loan, low-cost rental or giveaway programme, alongside education and guidance in their proper use. Incentive and education programmes that reward parents for correctly using child restraints or reward children for using them have been shown to be effective in increasing child restraint use in the short term (1–4 months) (19).

### 5.2.3 Choosing the performance indicators

Performance indicators (or outcome measures) are a measure of how successful the programme has been. Choice of performance indicators will be determined by the aims of the evaluation, the study type used, the resources available and, to a certain extent, the requirements of the funding agency. For instance, government funding agencies may require certain information to ensure support for increased enforcement or for further roll-out of a programme.

#### Injury and death outcomes

The effectiveness of seat-belts in reducing crash-related injury and death has been well documented in many studies (see Module 1) and there may be no need to replicate these findings in a large-scale (and possibly expensive) piece of experimental research. Although much of this effectiveness research has been conducted in high-income countries (predominantly the United States) there is no reason to believe that seat-belts would be less effective in preventing death and injury in low-income settings.

If it is necessary to calculate death and injury rates it may be possible to use routinely collected data as the basis for these calculations. However, the efficiency with which such rates can be calculated depends on the accuracy of local surveillance. If there is a uniform capture, coding and reporting system already set up in hospitals or health departments there may be aggregated data available on crash-related injury. Otherwise this may need to be abstracted from local data sources. Similarly, motor vehicle crash and death data may be routinely collected from police or transport authorities.

As quality may be variable, completeness and accuracy of these data sources should be carefully checked before use.

#### Seat-belt wearing rates

Possibly the most useful performance indicator to use in the evaluation of a seat-belt wearing campaign is the proportion of drivers and passengers wearing seat-belts. Observations of vehicle occupants may be made at a number of sites before and after a programme to document whether seat-belt wearing rates have changed.

#### Calculating rates

Comparing changes in absolute numbers in injury and death outcomes, or in drivers and passengers wearing seat-belts, before and after a programme is not useful, as absolute numbers may change due to an increase or decrease in the numbers of vehicles, registered or otherwise. It is therefore important that rates be calculated. Denominators may include number of vehicles, registered vehicles or kilometres travelled. For example, for injury outcomes a rate may be number of injuries per

licensed drivers, or number of injuries per 100 000 km driven. For seat-belt use, the appropriate rate would be the proportion of belted occupants over total occupants observed. Note that it is preferable to use a population denominator (for example per 100 000 population) rather than the number of vehicles as a denominator. This is because the rapidly increasing use of motor vehicles in many countries may distort the results of an evaluation, if this latter measure is used.

Module 2 includes a detailed section on how to measure seat-belt wearing rates.

#### 5.2.4 Conducting an economic evaluation of a programme

It may also be necessary to conduct an economic evaluation to demonstrate value for money and possible cost savings for government by investing in prevention. Economic evaluation addresses the question of whether one intervention represents a better use of resources than another. In other words, does spending \$X on programme A represent a better investment than \$X on programme B? To address this question, it is apparent that a comparison of two or more options is needed (sometimes this comparison is with a “do nothing” or “status quo” alternative).

Economic evaluation is based on the comparison of alternatives in terms of their costs and consequences (20). The term “consequences” is used here to represent an outcome of value. There are various forms of economic evaluation that can be conducted, each differing in terms of scope, i.e. the range of variables included in the analysis. Importantly, each form of economic evaluation typically entails a set of starting assumptions; recognition of these is necessary for the policy-maker to make appropriate use of the evidence from such studies.

A common element across all forms of economic evaluation is that they involve measuring costs. Costs usually comprise, at least in part, the direct programme costs – the resources that are used to run the programme (for example, equipment, staff, consumables). However, in principle, other costs may also be relevant, such as those incurred by patients, carers and the wider community. Furthermore, there are downstream costs and cost savings that may enter into consideration; for example, a programme may result in reduced hospitalizations and these savings in resources may be deemed relevant. The type of costs selected generally depends on the perspective taken in the evaluation and the nature of the resource allocation problem being addressed.

#### Methods used in economic evaluation

The most common form of economic evaluation is **cost–effectiveness analysis** (CEA). This entails placing the total cost of programmes alongside a defined outcome to produce a cost–effectiveness ratio (for example, cost per life saved, cost per life year saved or cost per case prevented). The assumption in CEA is that the objectives of interventions being compared are adequately captured in the measure of

outcome used (21). One modification to conventional cost–effectiveness analysis is cost–utility analysis, which is based on an outcome measure, the quality-adjusted life year (QALY). This incorporates changes in survival and quality of life and thereby enables a wider set of interventions to be legitimately compared than would be possible with CEA. The case study from China in section 5.1.2 shows the results of a cost–effectiveness study.

Another form of economic evaluation is **cost–benefit analysis**, which seeks to evaluate interventions in terms of total costs and total benefits, both dimensions being valued in monetary terms (for example dollars). Therefore if benefits are greater than costs, the decision would be to fund the programme. Valuation of health benefits in this way can be challenging, but one approach would be to elicit from beneficiaries of programmes their maximum willingness to pay for these benefits (i.e. if they had to pay for it in a hypothetical market place). The idea behind this approach is to derive a valuation for an intervention akin to the way in which consumers value goods and services in markets (22).

Cost–benefit analyses of seat-belt wearing show that the benefits clearly outweigh the costs, with benefit–cost ratios of between 3 and 8 (23).

Choosing the appropriate type of economic analysis for the needs of the particular programme will depend on resources available (both economic and human resources) and the aims of the evaluation.

### 5.2.5 Determining sample size

For all quantitative study types it is important to have sufficiently large numbers in the study to be sure that if an effect exists it is detectable. The rarer the event, the greater the sample size needs to be in order to detect a difference. Serious injuries from motor vehicle crashes are relatively rare events and a study using serious injury or death as an outcome would involve a large sample size. Measuring seat-belt wearing rates requires a smaller number of participants.

Factors that must be taken into consideration in determining the sample size are the expected size of the effect to be detected, variability in the measures and the prevalence of the variable of interest. For a cluster randomized trial, sample size calculations will also take the size of the cluster and correlation within clusters into account. For further information on sample size calculations for cluster randomized trials see reference 24.

Sample size calculators are freely available on the Internet, but it is wise to consult a statistician regarding such estimates, particularly where cluster randomized trials or random or stratified samples are necessary.



For quantitative study designs data will require statistical analysis. For more advice on how to go about this refer to reference 7, or see the relevant lectures in the basic methods and injury sections at <http://www.pitt.edu/~super1>.

## **5.3 Dissemination and feedback**

Once an evaluation is complete it is important to provide feedback to the stakeholders involved in the programme. Dissemination of the results will help to garner further support for the programme if it is successful, and help others gain support for the introduction of similar programmes. Publicity from dissemination activities may also increase the impact of the programme. If the programme has not been successful it is important to share this with others so that weaknesses or relevant issues are considered in other similar interventions, including whether or not to introduce such interventions.

Dissemination may involve presenting the results at public meetings, using the media to publicize the outcomes of the programme or publishing reports and papers in the scientific literature. Dissemination, translation and diffusion activities are often planned in advance so as to increase the chances for nationwide adoption of the effective interventions (25).

### **5.3.1 Checklist for evaluation process**

- Start evaluation process at the beginning of programme implementation.
- Determine aim of evaluation and develop evaluation framework.
- Clearly define target population, place and time.
- Develop and test instruments for data collection, ensuring consistency in training and measurement.
- Collect and analyse data.
- Write and disseminate evaluation report, feeding back into various aspects of programme.

### **5.3.2 Using evaluation results to feed back into new planning cycle**

Consider whether the evaluation demonstrated any tangible benefits – should the programme be continued, or does it require disbanding or modification? Can the existing programme be improved on the basis of the evaluation? Have there been any unexpected side effects of the programme?

The results of the evaluation should be fed back into the planning cycle and the appropriate modifications to the programme made before it is further expanded.

## **Summary**

Evaluation should be seen as an integral component of any seat-belt programme. An evaluation needs to be determined at the beginning of a programme development, such that the plan for data collection for this purpose is built into project implementation. As well as providing information on the effectiveness of a programme, evaluation will help identify if there are any problems in running a programme.

Determining the aims of the evaluation will help to decide how best to carry out the evaluation. There are a number of different methods that can be used to evaluate a seat-belt programme. Each method has various advantages and disadvantages, and the choice of which to use will depend on the aims of the programme and the resources available.

It is important that the results of the evaluation are shared with the appropriate parties, and that they are used in the planning of the programme. Dissemination, translation and diffusion of effective interventions will help increase the chances for nationwide adoption.

## **References**

1. Thompson NJ, McClintock HO. *Demonstrating your program's worth: a primer on evaluation for programs to prevent unintentional injury*. Atlanta, Centers for Disease Control and Prevention, National Center for Injury Prevention and Control, 1998.
2. Rossi PH et al. *Evaluation: a systematic approach*. California, Sage Publications, 2004.
3. THINK! Always wear a seat belt: rear seat belt campaign. Think! Road Safety Campaign, United Kingdom Department for Transport, 2003 (<http://www.thinkroadsafety.gov.uk/campaigns/seatbelts/rear.htm>, accessed 12 November 2008).
4. Zaza S et al. Methods for conducting systematic reviews of the evidence of effectiveness and economic efficiency of interventions to reduce injuries to motor vehicle occupants. *American Journal of Preventive Medicine*, 2001, 21(4S):23–30.
5. Stevenson M et al. Reducing the burden of road traffic injury: translating high-income country interventions to middle- and low-income countries. *Injury Prevention*, in press 2008.
6. Thompson NJ. Study methods for understanding injury behavior. In: Gielen A, Sleet DA, DiClemente R, eds. *Injury and violence prevention: behavioral science theories, methods and applications*. San Francisco, Jossey-Bass, 2006.
7. Britten N. Qualitative research: qualitative interviews in medical research. *British Medical Journal*, 1995, 311:251–253.
8. Kitzinger J. Qualitative research: introducing focus groups. *British Medical Journal*, 1995, 311:299–302.

9. Blantari J et al. An evaluation of the effectiveness of televised road safety messages in Ghana. *International Journal of Injury Control and Safety Promotion*, 2005, 12:23–29.
10. Goodson J, Buller C, Goodson W. Prenatal child safety education. *Obstetrics and Gynaecology*, 1985, 65:312–315.
11. Dowswell T, Towner E. Social deprivation and the prevention of unintentional injury in childhood: a systematic review. *Health Education Research*, 2002, 17:221–237.
12. Cohn LD et al. A program to increase seat belt use along the Texas-Mexico border. *American Journal of Public Health*, 2002, 12:1918–1920.
13. *Seat belts public education campaign*. Queensland Transport, 2004 ([http://www.roadsafety.qld.gov.au/qt/LTASinfo.nsf/ReferenceLookup/SeatbeltsPubEd.pdf/\\$file/SeatbeltsPubEd.pdf](http://www.roadsafety.qld.gov.au/qt/LTASinfo.nsf/ReferenceLookup/SeatbeltsPubEd.pdf/$file/SeatbeltsPubEd.pdf), accessed 12 November 2008).
14. Woodward M. *Epidemiology: study design and data analysis*, 2nd ed. Boca Raton, Chapman and Hall CRC, 2005.
15. Rothman KJ, Greenland S. *Modern epidemiology*, 2nd ed. Hagerstown, Maryland, Lippincott-Raven, 1998.
16. Towner E et al. *What works in preventing unintentional injuries in children and adolescents? An updated systematic review*. London, Health Development Agency, 2001.
17. Grossman G, Garcia D. Effectiveness of health promotion programs to increase motor vehicle occupant restraint use among young children. *American Journal of Preventive Medicine*, 1999, 16(1S):12–22.
18. Di Guiseppi C, Roberts I. Individual-level injury prevention strategies in the clinical setting. *Future Child*, 2000, 10(1):53–82.
19. Dinh-Zarr T et al. Reviews of evidence regarding interventions to increase the use of safety belts. *American Journal of Preventive Medicine*, 2001, 21(4S):48–65.
20. Drummond MF et al. *Methods for the economic evaluation of health care programmes*. Oxford, Oxford University Press, 1997.
21. Tan-Torres T et al, eds. *WHO guide to cost-effectiveness analysis*. Geneva, World Health Organization, 2003.
22. Miller TR. The effectiveness review trials of Hercules and some economic estimates for the stables. *American Journal of Preventive Medicine*, 2001, 21(4S):9–12.
23. Elvik R, Vaa T, eds. *The handbook of road safety measures*. Elsevier, 2004.
24. Kerry SM, Bland JM. Statistics notes: sample size in cluster randomisation. *British Medical Journal*, 1998, 316:549.
25. Sogolow E, Sleet DA, Saul J. Dissemination, implementation and widespread use of injury prevention interventions. In: Doll LS et al., eds. *Handbook of injury and violence prevention*. New York, Springer, 2007.





**Appendices**



<b>Appendix 1. United Nations Economic Commission for Europe (UNECE) seat-belt questionnaire . . . . .</b>	<b>165</b>
<b>Appendix 2. Sample seat-belt wearing observation form . . . . .</b>	<b>174</b>
<b>Appendix 3. Example seat-belt wearing law . . . . .</b>	<b>175</b>
<b>Appendix 4. Inspecting seat-belts and their components. . . . .</b>	<b>177</b>
<b>Appendix 5. Roadblock or checkpoint management. . . . .</b>	<b>185</b>
<b>Appendix 6. Sample lesson plan for teaching seat-belt safety in secondary school. . . . .</b>	<b>189</b>

# Appendix 1.

## United Nations Economic Commission for Europe (UNECE) seat-belt questionnaire

UNITED  
NATIONS

E



**Economic and Social  
Council**

Distr.  
GENERAL

TRANS/WP.1/2004/7/Rev.1  
21 July 2004

Original: English

**ECONOMIC COMMISSION FOR EUROPE**

**INLAND TRANSPORT COMMITTEE**

Working Party on Road Traffic Safety

(Forty-fifth session, 27–30 September 2004, agenda item 5(e))

**REVISION OF THE CONSOLIDATED RESOLUTIONS R.E.1 AND R.E.2**

**Increasing seatbelt usage**

**REVISED QUESTIONNAIRE ON SEATBELTS**

**AND CHILD RESTRAINTS POLICIES AND PROGRAMMES**

### A. Introduction

Motor vehicle crashes represent a major cause of fatality and injury, both in highly motorized, as well as developing countries. This is an issue that is a major public health problem, predicted to become even more of a global challenge over the next several decades. The use of safety belts and child restraint systems are the most effective means of reducing fatalities and serious injuries to vehicle occupants. Increasing the use of safety belts is also seen as the most effective defensive step individuals can take to reduce serious injury from the reckless behaviour of, for example, impaired drunk and drugged motorists and drivers displaying aggressive behaviour on the roadways.

This questionnaire was developed by the Special Work Group on Increasing Safety Belt Use set up during the 43rd session (22–25 September 2003) of the UNECE Working Party on Road Traffic Safety. Please refer to working document **TRANS/WP.1/2003/15, Use of Seat Belts**, for further information on the purpose and work mandate of this group.

**B. Explanation**

- The most appropriate person to fill out this survey would be a senior government official who has ongoing responsibility for managing and directing your country's policies, programmes and practices related to seat belt and child restraint use.
- Child restraints refers to a separate seat or device, used in concert with the vehicle, that secures the child, generally using the vehicle's seat belt devices, e.g. infant seats, booster seats, etc.
- Please attach, on a separate continuation sheet, to this questionnaire any further explanations to any of the questions that you feel are necessary.

**C. Overview**

1. What strategies does your Government use to raise seatbelt and child restraint use?

**Tick relevant boxes**

	Seatbelts	Child restraints
Legislation		
Enforcement		
Education		
Public information campaigns		
Other: please specify		

**D. Data/statistics**

2. Does your Government routinely collect detailed information about road traffic crashes that result in death or injury?

Yes

No

3. Does that data include information about whether seatbelts/child restraints were in use at the time of the crash?

Seatbelts:

Child restraints:

Yes

Yes

No

No

4. Do you routinely collect data on seatbelt/child restraint wearing?

Seatbelts:

Child restraints:

Yes

Yes

No

No

**If yes**, what was the most recent usage percentage?



Seat type	Front seat					Back seat			
	Driver	Passenger	Children under 12 with child restraints*			Passengers	Children under 12 with child restraints*		
			FFCRS	RWCRS	Booster		FFCRS	RWCRS	Booster
Usage %									
Date collected	___/___/___	___/___/___	___/___/___			___/___/___	___/___/___		

\* Child restraints (CRS): covers forward-facing (FFCRS) and rear-facing child restraints (RWCRS) and booster seats.

**5. How do you collect information about seatbelt and child restraint wearing? Check all that apply:**

Seatbelts:

- Observation
- Crash data
- Self-reported by occupants
- Opinion/telephone surveys
- Other, please state:  
.....

Child restraints:

- Observation
- Crash data
- Self-reported by occupants
- Opinion/telephone surveys
- Other, please state:  
.....

**E. Legislation**

**6. In your country, are vehicles legally required to have seatbelts fitted/installed?**

		Front		Rear		Centre rear	
		Y/N	Year	Y/N	Year	Y/N	Year
<b>Cars</b>	Passenger cars						
	Non-commercial vans, Multi-purpose vehicles (MPVs) <sup>1</sup>						
	Sports utility vehicles (SUVs) <sup>2</sup>						
<b>Commercial vehicles</b> (trucks, goods carriers, commercial vans)							
<b>Buses</b>	Public buses						
	Tourist buses/motor coaches						
	Minibuses						
	School buses						

<sup>1</sup> MPVs or non-commercial vans (for the US and Canada) are also called people carriers. They provide space for more vehicle occupants than in a normal passenger car (e.g. 7 seats) and provide more luggage capacity.

<sup>2</sup> SUVs: e.g. 4 x 4, pick-up trucks.

7. Do you have an international or domestic technical standard for seatbelt installation/performance?

Yes

No

If yes, please state: .....

.....

8a. Is your seatbelt legislation:

Federal/National

State/Provincial

Extra comments: .....

.....

8b. Do you have legislation making seatbelt use mandatory?

		Front <sup>1</sup>		Rear <sup>2</sup>	
		Y/N	Year	Y/N	Year
Cars	In any circumstance				
	In town only				
	Outside town only				
Commercial vehicles	In any circumstance				
	In town only				
	Outside town only				
Buses	In any circumstance				
	In town only				
	Outside town only				
Public buses	In any circumstance				
	In town only				
	Outside town only				
Tourist buses / minibuses	In any circumstance				
	In town only				
	Outside town only				
School buses	In any circumstance				
	In town only				
	Outside town only				

<sup>1</sup> For commercial vehicles and buses, driver and co-driver, if applicable.

<sup>2</sup> For buses, it concerns passengers.

9a. Are there exemptions for mandatory use?

Yes

No

**If yes, please state:**

- Medical reasons
- Size (too small or too big)
- Taxi driver in service
- Police
- Fire vehicles
- Ambulances
- Mail services in town
- Vehicles carrying out deliveries
- Other, please state:

.....  
 .....

**9b.** When there are medical reasons, does an official medical certificate have to be present for checking?

- Yes (What is the maximum duration: .....)
- No

**9c.** Does this certificate have a symbol recognised at an international level?

- Yes
- No

**10a.** Do you have legislation making child restraint use mandatory?

	National/federal law	State/provincial law	Front	Rear	Date law enacted
Yes					
No					

**10b.** Please provide a breakdown of legal requirements by age bands and specific child restraint type\*:

Age band (e.g. 0–2)	Type of restraint	Seating position (if specified)	
		Front	Rear

\* Child restraint: forward-facing (FFCRS) or rear-facing (RWCRS) child restraint or booster seat.

Would you like to add any other observations? (e.g. is a particular child restraint not allowed in a particular seating position?)

.....  
 .....

11. Are drivers in buses/taxis obliged to carry child restraints?

- Yes
- No

If yes, please state:.....

.....

**F. Enforcement**

12. What are the sanctions for violations of seatbelt/child restraint laws?

		Seatbelts	Child restraints
Monetary fines – amount:	Driver		
	Passenger		
Penalty points against driver's license, if applicable. Specify number/total points:		__/__	__/__
Other: please state: ..... .....			

13. Are the police involved in any seatbelt/child restraint activities other than enforcing seatbelt/child restraint laws?

- Yes
- No

If yes, briefly describe:

.....  
 .....

**G. Education**

14. Do you have a road safety education programme in schools?

- Yes
- No

15. At what age does the education programme start?

.....

16a. Does the education programme include information about seatbelts?

- Yes
- No

**If yes**, what type of information is included?

.....  
 .....

**16b.** Does the education programme include information about child restraints?

Yes

No

**If yes**, what type of information is included?

.....  
 .....

**17.** Does the wider national education programme for the rest of the population include information for parents/carers, e.g. grandparents, about correct child restraint use?

Yes

No

**18.** In the last 12 months, has your Government advertised seatbelt messages using the following media? Please tick all that apply:

**Seatbelts:**

- TV campaigns
- Radio campaigns
- Cinema advertising
- Outdoor/posters/billboards
- Leaflets
- Print e.g. newspapers, magazines
- Internet, new media
- Public relations
- Other, please describe:

.....  
 .....

**Child restraints:**

- TV campaigns
- Radio campaigns
- Cinema advertising
- Outdoor/posters/billboards
- Leaflets
- Print e.g. newspapers, magazines
- Internet, new media
- Public relations
- Other, please describe:

.....  
 .....

**19.** Do you use shock tactics in advertising?

Yes

No

**If yes**, how does the impact compare with more subtle tactics?

.....  
 .....

**H. Evaluation and research**

20. Do you routinely measure the effectiveness of your seatbelt programme?

Yes

No

**If yes**, how do you determine the impact of:

a) individual interventions (e.g. a new law enacted, a new TV advertisement)

.....  
.....

b) the entire seatbelt strategy (e.g. seatbelt wearing rates, reduction of casualty rates, awareness of seatbelt messages, publicity, etc.)

.....  
.....

21. Have you carried out research into the characteristics of people who don't use safety restraints?

Yes

No

**If yes**, how did you use the information?

.....  
.....

22. Do you enlist the support of third parties to help focus on and improve seatbelt use among some low use groups, e.g. young men 16–24?

Yes

No

**If yes**, please give examples:

.....  
.....

23. Does your seatbelt programme offer your stakeholders incentives to help (e.g. grants, additional police equipment, etc.) to increase seatbelt/child restraint use:

**Seatbelts**

- Enforcement bodies
- Other governmental bodies
- Vehicle users
- Other, please state:

.....  
.....

**Child restraints**

- Enforcement bodies
- Other governmental bodies
- Vehicle users
- Other, please state:

.....  
.....

**If yes, please give examples for seatbelts:**

.....  
.....

**If yes, please give examples for child restraints:**

.....  
.....

Name of person responding to this survey:.....
Title: .....
Service and/or administration:.....
.....
May we contact you if we have questions about any of your answers?
<input type="checkbox"/> Yes <input type="checkbox"/> No
E-mail:.....
Telephone number:..... Fax number:.....

## Appendix 2.

### Sample seat-belt wearing observation form

TRRL CAR OCCUPANT RESTRAINT USAGE SURVEY			Ref. No. _____
FRONT SEAT PASSENGER	CENTRE PASSENGERS	DRIVER	
<input type="checkbox"/> Male <input type="checkbox"/> Female	<input type="checkbox"/> <input type="checkbox"/>	<input type="checkbox"/> Male <input type="checkbox"/> Female	<input type="checkbox"/>
<input type="checkbox"/> 14y + <input type="checkbox"/> Large child (10-13) <input type="checkbox"/> Medium child (5-9) <input type="checkbox"/> Small child (1-4) <input type="checkbox"/> Baby (0-1)	<input type="checkbox"/> <input type="checkbox"/>	Age <input type="checkbox"/> 17-29 <input type="checkbox"/> 30-59 <input type="checkbox"/> 60+	<input type="checkbox"/>
<input type="checkbox"/> Un-restrained <input type="checkbox"/> Seat belt <input type="checkbox"/> Child seat <input type="checkbox"/> Rear facing seat <input type="checkbox"/> Carrycot-strapped <input type="checkbox"/> Carrycot-Unstrapped	<input type="checkbox"/>	<input type="checkbox"/> Un-restrained <input type="checkbox"/> Seat belt	<input type="checkbox"/>
<input type="checkbox"/> Occupant on lap	<input type="checkbox"/>		
<hr/>			
<input type="checkbox"/> Male <input type="checkbox"/> Female	<input type="checkbox"/> <input type="checkbox"/>	<input type="checkbox"/> Male <input type="checkbox"/> Female	<input type="checkbox"/>
<input type="checkbox"/> 14 + <input type="checkbox"/> Large child (10-13) <input type="checkbox"/> Medium child (5-9) <input type="checkbox"/> Small child (1-4) <input type="checkbox"/> Baby (0-1)	<input type="checkbox"/> <input type="checkbox"/>	14 + <input type="checkbox"/> Large Child(10-13) <input type="checkbox"/> Medium child(5-9) <input type="checkbox"/> Small child (1-4) <input type="checkbox"/> Baby (0-1)	<input type="checkbox"/>
<input type="checkbox"/> Un-restrained <input type="checkbox"/> Seat belt <input type="checkbox"/> Child seat <input type="checkbox"/> Rear facing seat <input type="checkbox"/> Carrycot-strapped <input type="checkbox"/> Carrycot-Unstrapped	<input type="checkbox"/>	<input type="checkbox"/> Un-restrained <input type="checkbox"/> Seat belt <input type="checkbox"/> Child seat <input type="checkbox"/> Rear facing seat <input type="checkbox"/> Carrycot-strapped <input type="checkbox"/> Carrycot-Unstrapped	<input type="checkbox"/>
<input type="checkbox"/> Occupant on lap	<input type="checkbox"/>	<input type="checkbox"/> Occupant on lap	<input type="checkbox"/>
<hr/>			
Note any odd details of rear seat passengers or any occupants behind rear seats:			
			Comment <input type="checkbox"/>
<hr/>			
VEHICLE DETAILS Registration letter (1st letter)	G/F <input type="checkbox"/> E <input type="checkbox"/> D <input type="checkbox"/> C Older <input type="checkbox"/> Other	<input type="checkbox"/>	Taxi <input type="checkbox"/> (Personal, Forces etc.)

Source: Broughton J. *Restraint use by car occupants 1982-1989*. Research Report 289. Crowthorne, United Kingdom, TRL Ltd. 1990.



## Appendix 3.

# Example seat-belt wearing law

### Model Law

#### Standard (Primary) Safety Belt Model Law

#### National Committee on Uniform Traffic Laws and Ordinances

June 16, 1997

**Purpose:** The purpose of this legislation is to reduce injuries and fatalities on the streets, roads and highways by requiring all drivers and all passengers to wear safety belts meeting applicable federal motor vehicle safety standards while riding in motor vehicles and by authorizing primary enforcement.

#### Section 1: Title

This act may be cited as the [State's] Safety Belt Use Act.

#### Section 2: Definitions

As used in this act:

(a) "Motor vehicle" means any motor vehicle having a gross vehicle weight of 10,000 pounds or less that is required to be equipped with safety belts by Federal Motor Vehicle Safety Primary No. 208. Passenger cars are required to have belts if built after December 31, 1967. Light trucks and multi-purpose vehicles are required to have safety belts if built after December 31, 1971.

(b) "Driver" means a person who drives or is in actual physical control of a motor vehicle.

(c) "Safety belt" means any strap, webbing, or similar device designed to secure a person in a motor vehicle including all necessary buckles and other fasteners, and all hardware designed for installing such safety belt assembly in a motor vehicle.

#### Section 3: Application

This act shall apply to drivers and all occupants of motor vehicles on the streets, roads, and highways of this State.

#### **Section 4: Operation of motor vehicles with safety belts**

(a) Each driver of a motor vehicle in this State shall have a safety belt meeting applicable federal motor vehicle safety standards properly fastened about his or her body at all times when operating a motor vehicle.

[(b) Alternate 1 – The driver of a motor vehicle in this State shall not operate a motor vehicle unless the driver secures or causes to be secured in a properly adjusted and fastened safety belt or child restraint system meeting applicable federal motor vehicle safety standards all passengers and secures any passenger 12 or younger in the rear seat, unless all available rear seats are in use by other passengers 12 or younger.]

[(b) Alternate 2 – The driver of a motor vehicle in this State shall not operate a motor vehicle unless every occupant is secured in a properly adjusted and fastened safety belt or child restraint system meeting applicable federal motor vehicle safety standards and consistent with the [State's] child restraint use law.]

(c) Every occupant of a motor vehicle in this State shall have a safety belt meeting applicable federal motor vehicle safety standards properly fastened about his or her body at all times when the vehicle is in operation.

#### **Section 5: Exemptions**

(a) The provisions of sections (4) (c) shall not apply to children covered by [cite to the State's child restraint use act or law].

(b) The provisions of section (4) shall not apply to persons with a physically disabling condition whose physical disability would prevent appropriate restraint in safety belts, provided, however, such condition is duly certified by a physician who shall state the nature of the condition, as well as the reason such restraint is inappropriate.

(c) The provisions of this law shall not apply to passenger cars built prior to December 31, 1967 and possessing no safety belts.

(d) The provisions of this law shall not apply to passenger vehicles which are not required to be equipped with safety belts under federal law.

#### **Section 6: Penalties**

A person who violates section (4) (a), (b), or (c) of this act shall be punished by a fine of not less than \$25.00 nor more than \$50.00, [and court costs] and [for States with points systems] 2 demerit points.

*Source:* National Highways Traffic Safety Administration, USA  
(<http://www.nhtsa.dot.gov/people/injury/enforce/PrimaryEnforcement/images/PrimaryEnforcement.pdf>, accessed 12 November 2008).

## Appendix 4.

# Inspecting seat-belts and their components

(from United Kingdom Vehicle Inspectorate inspection manual)

## 5.1 Seat Belts

Information	Method of Inspection	Reason for Rejection
<p><b>This inspection applies to</b> Only those seat belts <b>which are required to be fitted</b>. The vehicle presenter should be informed of a defect noticed on any additional seat belt fitted.</p>	<ol style="list-style-type: none"> <li>1. Check that each seat which requires a seat belt is fitted with one of the appropriate type (see table on pages 4 &amp; 5).</li> <li>2. Pull each seat belt webbing against its anchorage to see that it is properly secured to the vehicle structure. <b>Note:</b> For seats with integral seat belts, it might not be possible to examine the fixing of the seat belt to the seat.</li> <li>3. Examine the condition of all seat belt webbing for cuts or obvious signs of deterioration. Pay particular attention to webbing around anchorages, buckles and loops.</li> <li>4. Examine the condition of the attachment fittings and adjusting fitting on each belt.</li> <li>5. Examine flexible buckle stalks for               <ol style="list-style-type: none"> <li>a. signs of corrosion or weakness. Pull the sheaths aside, if this can be done without damage</li> <li>b. 'waggle' flexible buckle stalks and listen for a clicking noise indicating broken strands of cable</li> </ol> </li> </ol>	<ol style="list-style-type: none"> <li>1. A seat belt missing or of the wrong type.</li> <li>2.               <ol style="list-style-type: none"> <li>a. a seat belt not securely fixed to the seat or to the structure of the vehicle. For example, a fixing bolt not secure</li> <li>b. for seats with integral seat belts, any insecure attachment of the seat to the vehicle structure</li> </ol> </li> <li>3.               <ol style="list-style-type: none"> <li>a. a cut which causes the fibres to separate</li> <li>b. fluffing or fraying sufficient to obstruct correct operation of the belt or which has clearly weakened the webbing</li> <li>c. stitching badly frayed, not secure, incomplete or repaired</li> </ol> </li> <li>4. An attachment fitting or adjustment fitting of a seat belt fractured or badly deteriorated.</li> <li>5.               <ol style="list-style-type: none"> <li>a. corrosion or deterioration of a flexible stalk likely to lead to failure under load</li> <li>b. broken strands of a flexible stalk cable</li> </ol> </li> </ol>
	<p><b>Method of Inspection</b></p> <ol style="list-style-type: none"> <li>6. Fasten each belt locking mechanism and try to pull the locked sections apart. On retracting seat belts, check that with the mechanism fastened and the seat unoccupied, excess webbing is wound into the retracting unit. <b>Note:</b> Some types of retracting belt might need manual help before they retract. Operate the release mechanism while pulling on the belt to check that the mechanism releases when required.</li> <li>7. As far as is practicable without dismantling, check the condition of the vehicle structure around the seat belt anchorage points (ie within the 'prescribed area' see Appendix C). The floor-mounted anchorage points might need to be inspected from underneath the vehicle.</li> </ol>	<p><b>Reason for Rejection</b></p> <ol style="list-style-type: none"> <li>6.               <ol style="list-style-type: none"> <li>a. the locking mechanism of a seat belt does not secure or release the belt as intended</li> <li>b. a retracting mechanism does not retract the webbing sufficiently to remove <b>all</b> the slack from the belt with the locking mechanism fastened and the seat <b>unoccupied</b> <b>Note 1:</b> In doubtful cases, this should be checked with the seat base set in its rearmost position. <b>Note 2:</b> The vehicle presenter should be advised of and given the opportunity to remove any temporarily fitted device likely to cause failure under this reason for rejection before notification of refusal is issued.</li> </ol> </li> <li>7. Deliberate modification which significantly reduces the original strength, excessive corrosion, severe distortion, a fracture or an inadequate repair of a load bearing member or its supporting structure or panelling within 30cm of a seat belt anchorage. <b>Note:</b> For integral seat belt anchorages, this reason for rejection applies to any part of the seat frame between the anchorage point and the nearest rearmost seat mounting to the vehicle structure. The 30cm rule applies to the vehicle structure near that seat mounting.</li> </ol>

## Seat belt requirements for vehicles first used before 1 April 1987

### Vehicle Description

<p>1. <b>Passenger and dual purpose vehicles</b></p> <ul style="list-style-type: none"> <li>with 4 or more wheels</li> <li>with up to 12 passenger seats</li> <li>first used on or after 1 January 1965</li> </ul> <p>2. <b>3-wheeled vehicles</b></p> <ul style="list-style-type: none"> <li>with an unladen weight over 410Kg first used on or after 1 January 1965, or</li> <li>with an unladen weight over 255Kg if first used on or after 1 September 1970</li> </ul> <p>Except vehicles</p> <ul style="list-style-type: none"> <li>less than 410Kg unladen, equipped with a driving seat of a type requiring the driver to sit astride it, and</li> <li>constructed or assembled by a person not ordinarily engaged in the trade or business of manufacturing vehicles of this type.</li> </ul> <p>3. <b>Goods vehicles, motor caravans and ambulances</b></p> <ul style="list-style-type: none"> <li>with an unladen weight <b>not exceeding 1525Kg</b></li> <li>first used on or after 1 April 1967</li> </ul> <p>4. <b>Goods vehicles, motor caravans and ambulances</b></p> <ul style="list-style-type: none"> <li>with a design gross weight <b>not exceeding 3500Kg</b></li> <li>first used on or after 1 April 1980</li> </ul> <p>except those first used before 1 April 1982, if they are of a model manufactured before 1 October 1979 with an unladen weight exceeding 1525Kg.</p>
--

### Seat Position

Driver's and "Specified Front Passenger's" Seat (See Note 1 below)	Centre Front Seat	Forward Facing Rear Seats
A. Vehicles first used before 1 April 1981: A belt which restrains the upper part of the body (but need not include a lap belt) for each seat.	No requirement	No requirement
B. Vehicles first used after 31 March 1981: A 3 point (lap/diagonal) belt (see Note 2 below)		

**Note 1:** The "specified front passenger seat" requiring a seat belt is the seat which is

- Foremost in the vehicle, and
- Furthest from the driver's seat

unless there is a fixed partition separating the passenger seat from a space in front of it which is alongside the driver's seat, eg certain types of taxis, buses etc.

**Note 2:** '3 point belt' means a seat belt which

- restrains the upper and lower parts of the torso
- includes a lap belt
- is anchored at not less than three points, and
- is designed for use by an adult

**Note 3:** An adult harness belt comprising a lap belt and shoulder straps bearing a British Standard marking is an acceptable alternative to any of the seat belt types listed.

## Seat belt requirements for vehicles first used before 1 April 1987

### Vehicle Description

<p>1. <b>Passenger and dual purpose vehicles</b></p> <ul style="list-style-type: none"> <li>with 4 or more wheels</li> <li>with up to 12 passenger seats</li> <li>first used on or after 1 January 1965</li> </ul> <p>2. <b>3-wheeled vehicles</b></p> <ul style="list-style-type: none"> <li>with an unladen weight over 410Kg first used on or after 1 January 1965, or</li> <li>with an unladen weight over 255Kg if first used on or after 1 September 1970</li> </ul> <p>Except vehicles</p> <ul style="list-style-type: none"> <li>less than 410Kg unladen, equipped with a driving seat of a type requiring the driver to sit astride it, and</li> <li>constructed or assembled by a person not ordinarily engaged in the trade or business of manufacturing vehicles of this type.</li> </ul> <p>3. <b>Goods vehicles, motor caravans and ambulances</b></p> <ul style="list-style-type: none"> <li>with an unladen weight <b>not exceeding 1525Kg</b></li> <li>first used on or after 1 April 1967</li> </ul> <p>4. <b>Goods vehicles, motor caravans and ambulances</b></p> <ul style="list-style-type: none"> <li>with a design gross weight <b>not exceeding 3500Kg</b></li> <li>first used on or after 1 April 1980</li> </ul> <p>except those first used before 1 April 1982, if they are of a model manufactured before 1 October 1979 with an unladen weight exceeding 1525Kg.</p>
--

### Seat Position

Driver's and "Specified Front Passenger's" Seat (See Note 1 below)	Centre Front Seat	Forward Facing Rear Seats
A. Vehicles first used before 1 April 1981: A belt which restrains the upper part of the body (but need not include a lap belt) for each seat.	No requirement	No requirement
B. Vehicles first used after 31 March 1981: A 3 point (lap/diagonal) belt (see Note 2 below)		

**Note 1:** The "specified front passenger seat" requiring a seat belt is the seat which is

- Foremost in the vehicle, and
- Furthest from the driver's seat

unless there is a fixed partition separating the passenger seat from a space in front of it which is alongside the driver's seat, eg certain types of taxis, buses etc.

**Note 2:** '3 point belt' means a seat belt which

- restrains the upper and lower parts of the torso
- includes a lap belt
- is anchored at not less than three points, and
- is designed for use by an adult

**Note 3:** An adult harness belt comprising a lap belt and shoulder straps bearing a British Standard marking is an acceptable alternative to any of the seat belt types listed.

## Seat belt requirements for vehicles first used after 31 March 1987

Vehicle Description	Seat Position		
	Driver's and "Specified Front Passenger's" Seat (See Note 1, page 4)	Centre Front Seat	Forward Facing Rear Seats
1. Passenger vehicles and dual purpose vehicles with not more than 8 passenger seats, except 3 wheeled vehicles <ul style="list-style-type: none"> <li>▪ with an unladen weight of 255Kg or less</li> <li>▪ with an unladen weight over 255Kg but less than 410Kg</li> <li>– equipped with a driving seat of a type requiring the driver to sit astride it, and</li> <li>– constructed or assembled by a person not ordinarily engaged in the trade or business of manufacturing vehicles of this type</li> </ul>	3 point belts for each seat. (See Notes 2 & 3, page 4)	3 point belt, lap belt or a disabled person's belt.	A. Vehicles with <b>not more</b> than 2 rear seats: Either <ul style="list-style-type: none"> <li>i. A 3 point inertia reel belt for at least one seat; or</li> <li>ii. A 3 point belt, lap belt, disabled person's belt or child restraint for each seat.</li> </ul> B. Vehicles with more than 2 rear seats: Either <ul style="list-style-type: none"> <li>i. A 3 point inertia reel belt on an outboard seat and a 3 point static or inertia reel belt, lap belt, disabled persons belt or child restraint for at least one other seat; or</li> <li>ii. A static 3 point belt for one seat and a disabled person's belt or child restraint for at least one other seat; or</li> <li>iii. A 3 point belt, lap belt, disabled person's belt or child restraint for each seat.</li> </ul> See additional information on pages 6 & 7.
2. Goods Vehicles	As above	As above	No requirement (see Notes 5 & 6, page 7)
3. Vehicles first used before 1 October 1988 which are: <ul style="list-style-type: none"> <li>▪ minibuses with up to 12 passenger seats</li> <li>▪ motor caravans and ambulances with a design gross weight not exceeding 3500kg</li> </ul>	As above	No requirement	No requirement
4. Minibuses, motor caravans and ambulances <ul style="list-style-type: none"> <li>▪ with a design gross weight not exceeding 3500Kg</li> <li>▪ first used after 30 September 1988</li> </ul>	As above	3 point belt or a lap belt	No requirement

## Seat Belts (Additional information: Forward facing rear seats)

Vehicles first used after 31 March 1987. Forward facing rear seats must have **at least** the type and number of seat belts shown below.

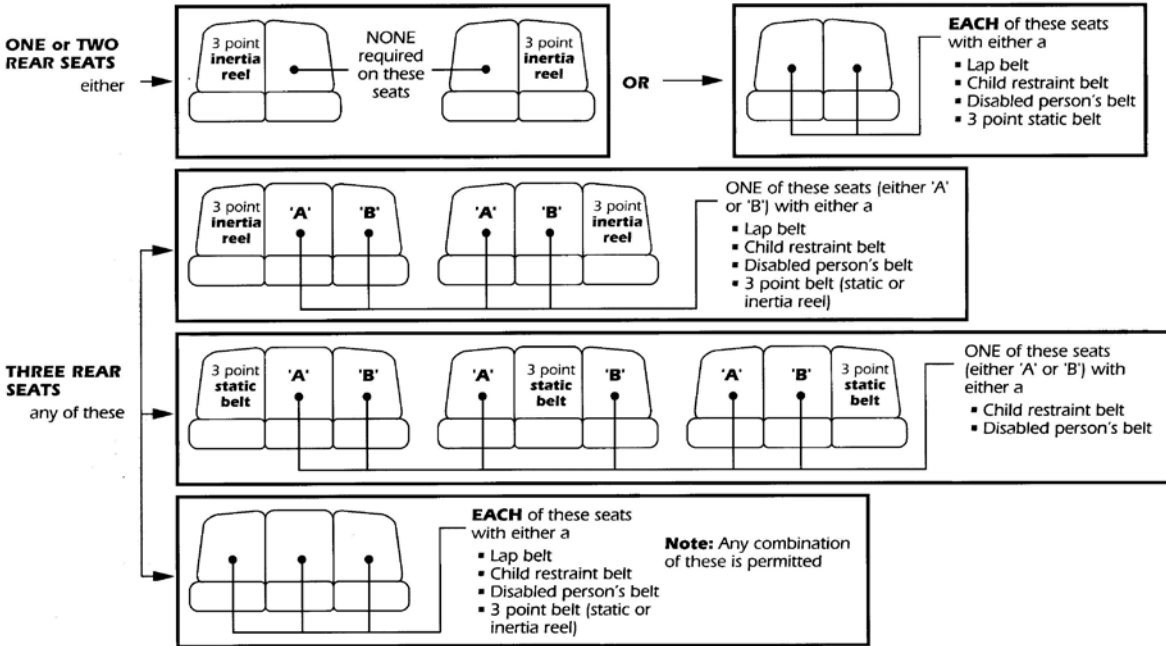

## Seat Belts (Additional information: Forward facing rear seats)

**MORE THAN THREE REAR SEATS**

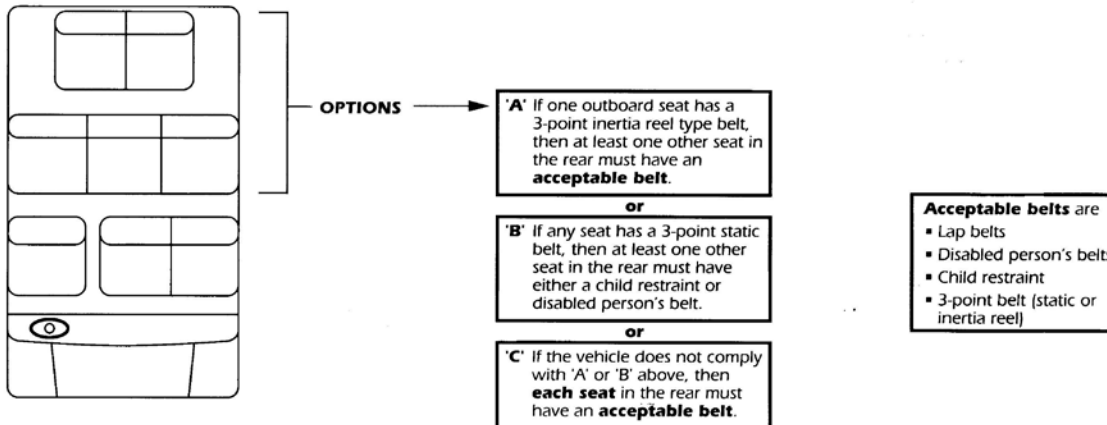

**Note 1:** Outboard seats are seats closest to the vehicle sides.

**Note 2:** Rear seat belts are not required for vehicles with more than 8 passenger seats in any configuration.

**Note 3:** Rear facing or side facing seats are not required to be fitted with seat belts.

**Note 4:** Occasional seats that fold when not in use, fitted in the rear of extended limousines, are not required to be fitted with seat belts.

**Note 5:** Seats fitted to the rear of the driver's compartment in a goods vehicle do not require to be fitted with seat belts (unless the seat is the specified passenger seat, see Note 1, page 4).

**Note 6:** A goods vehicle (eg. a car derived van) which has been converted to a passenger vehicle specification (ie. fitted with rear seats and side windows etc) is required to comply with the 'passenger vehicle' requirements.

## Structural Integrity and Corrosion

## Appendix **C**

### 1. Introduction

The effect of corrosion on the safety of a vehicle depends on

- Its extent
- The function of the section on which it has occurred

A small amount of corrosion on an important part of a vehicle structure can make a vehicle unsafe where it destroys the continuity of the load bearing structure.

On the other hand, heavy corrosion of unimportant sections may have no effect on the vehicle's safety.

Corrosion of a particular part, such as a body sill, may be very important on one type of construction, but of less importance on another. This is shown in figures A to D where the shaded portions indicate the important load bearing parts of different typical vehicle constructions.

### 2. Prescribed Areas

To assist with the assessment of corrosion, Sections 2, 3 and 5 of the Manual identify the parts of the vehicle structure which are particularly important and to which particular attention must be paid during an inspection.

These are

- The load bearing parts of the vehicle to which certain testable items (as specified in Section 2, 3 and 5) are mounted

- Any structure or panelling which is supportive to either the component mounting or its load bearing member within 30cm of the mounting location. eg. In the examination of a seat belt mounting on an inner sill, consideration must be given to the outer sill, door pillar, floor panel, wheel arch or any other supportive structure within 30cm of the component mounting point.

Section 6 of the Manual deals with structural cracks, fractures, damage or corrosion not within the 'prescribed areas'.

### 3. Assessment

Having identified the important load bearing members and 'prescribed areas' on a vehicle, the tester should determine whether they are excessively corroded, firstly by **visual inspection** and then by **finger/thumb pressure**.

If necessary careful scraping or light tapping of the affected areas with the Corrosion Assessment Tool is permitted.

Excessively corroded metal, or metal treated with filler, emits a duller sound than does unaffected metal. It is not necessary to apply heavy impact blows or to use a sharp instrument to "dig" at the structure.

### 4. Failure Criteria

Any part of a load bearing member, or load bearing panelling within a 'prescribed area', should be rejected if it is weakened by corrosion to the extent that

- By finger/thumb pressure it does not feel rigid, or
- It crumbles to leave a hole, or
- The Corrosion Assessment Tool
  - penetrates, or
  - causes the metal component to crumble or disintegrate

[See Section 6.5 for the vehicle structure not within a 'prescribed area'].

Severe distortion means distortion considered to reduce the strength of a component mounting, supporting structure, panelling or load bearing member significantly.

### 5. Highly stressed components

The severity of general or local corrosion in highly stressed steering and suspension components (eg. arms, rods, levers etc) can be assessed by lightly tapping or scraping with the Corrosion Assessment Tool.

A small screwdriver may be used to push and probe, but only in places inaccessible to the Corrosion Assessment Tool.

A highly stressed component should be rejected if it has been

- Seriously reduced in overall thickness by corrosion, or
- Local corrosion has resulted in even a small hole or split

## **C** Appendix

## Structural Integrity and Corrosion

### 6. Corrosion Assessment Tool

The Corrosion Assessment Tool **must be used carefully** to avoid unnecessary damage. The tool comprises

- A durable engineering plastic head for light tapping, and
- An aluminium alloy shaft with a curved 'spade end' for light scraping. The alloy shaft can also be used as a small lever

#### WARNING

The curved spade end must only be used for light scraping and not to prod and poke the vehicle structure.

### 7. Safety Precautions

Eye protection is recommended when assessing corrosion in vehicle structures and components. Any sharp edges on the Corrosion Assessment Tool should be removed.

### 8. General Guidance

Corrosion which has not reduced the metal thickness sufficiently to weaken it will clearly not warrant rejection. However, the tester should inform the vehicle presenter that corrosion has started.

On the other hand, where there is severe corrosion, it may be necessary to refuse to carry out a brake test if this could cause danger or further damage.

### 9. Thin gauge steel pressings

In some vehicles, comparatively thin gauge steel pressings are used for certain steering and suspension components, mountings, sub-frames and cross members.

Many of these parts have hollow sections or upfacing areas in which road dirt impregnated with salt or other chemicals collects causing serious but often very localised corrosion.

In some cases where large quantities of salt are used on roads, corrosion has caused the failure of steering and suspension components within three years. Some components have been known to fail completely at one end and still be undamaged at the other.

### 10. Platform or underframe

Some vehicle types (such as VW "Beetle" etc) have bodies and various mechanical parts attached to a platform or underframe which is the main load bearing structure. Defective body panels considered to be part of a load bearing structure should only be rejected if they

- a. play an active part in directly supporting the steering, suspension, braking components or seat belt anchorages, or
- b. are likely to adversely affect the correct functioning of the braking system or steering gear (eg by fouling a wheel)

### 11. Corrosion around drainage holes

Corrosion can be more prevalent in areas around drainage holes due to the ingress of moist air, dirt, road salt etc. Therefore, special attention should be paid to these areas of the important structural and testable components.

### 12. Method of Repair

It is essential that repairs to corroded areas are properly carried out. Only welding is acceptable for repairs to 'prescribed areas'.

Suitable materials of appropriate gauge or thickness should be used for repairs so that

- Any plating or welding extends to a sound part of a load bearing component, and
- The repair must be virtually as strong as the original structure

So only a continuous seam weld is acceptable for patch repairs, although spot welded joints are acceptable where they originally existed.

Welded repairs to highly stressed components such as steering/suspension arms, rods, levers etc are not normally acceptable.

## Structural Integrity and Corrosion

## Appendix C

### 13. Brazing, soldering, glass fibre and body filler

These are bonding processes and are **not** regarded as strong enough for repairs to load bearing members although they are normally adequate for other repair work.

Brazing, bonding and riveting are only acceptable where used by the vehicle manufacturer and the standard of any such repair must be comparable to the original.

### 14. Identifying types of repair

It is sometimes difficult to distinguish between welding and brazing after the repair has been covered in paint or underseal. However, brazing may be detected by the smooth fillet of filler or a gold coloration at the edge of a joint.

Glass fibre, body filler, aluminium etc may often be detected by a difference

- In appearance, or
- In sound when tapped, or
- By the use of a magnet

### Non-metallic vehicle structure

#### 15. Plastic and Fibreglass

Plastics are becoming more common in vehicle structures. Glass reinforced plastic (GRP - also known as Fibreglass) is the most common, and variations include bodies with metal chassis or subframes and plastic monocoque (chassis-less) construction.

#### 16. Testable items mounted to plastic structures

Testable items, such as steering racks, subframes and seat belts, are sometimes mounted directly to plastic structures which do not have metal reinforcement.

Although usually designed to support these components, some are not, particularly self build kits.

Non-metallic structures must be assessed on their merits. Look for evidence of weakness. Cracks, separation or delamination within a 'prescribed area' or a component flexing on its mounting to the extent that it is clear that it is likely to work loose or break away are reasons for rejection.

#### 17. Repairs to plastics

- Within a 'prescribed area', or
- Which affect the load bearing structure should be as strong as the original part.

### 18. Structural integrity and the removal or substitution of metal panels

On a vehicle of integral construction the strength and stiffness of the whole structure may be seriously effected by any panel being removed or replaced by a panel of different material.

In considering whether the original strength and stiffness has been **significantly reduced** following a modification, the tester must consider whether he/she is qualified to make this assessment.

If the tester decides that the modification renders the vehicle unsafe, he/she must issue a 'Notification of Refusal' within Inspection Manual item 6.5 Reason for Rejection 1.

It is unacceptable for plastics to replace or reinforce corroded or weak metal in 'prescribed areas' or load bearing members or components.

## C Appendix

## Structural Integrity and Corrosion

Figure A

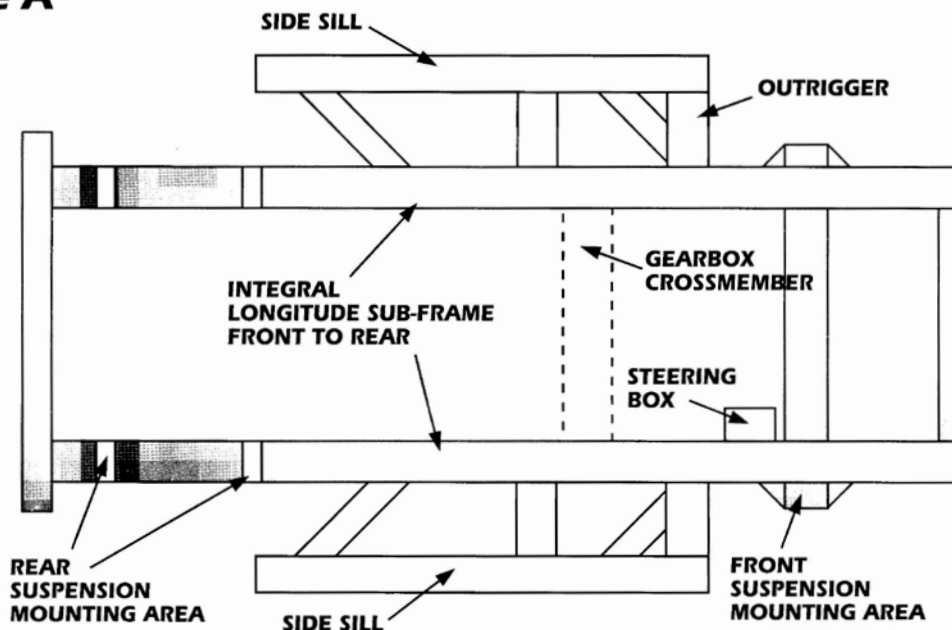



**Structural Integrity and Corrosion**

**Appendix C**

**Figure B**

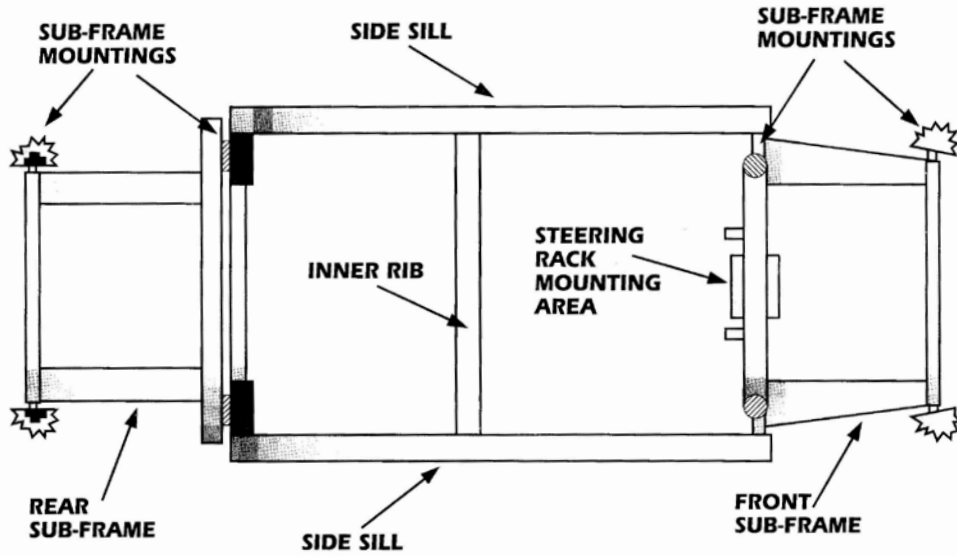

**C Appendix**

**Structural Integrity and Corrosion**

**Figure C**

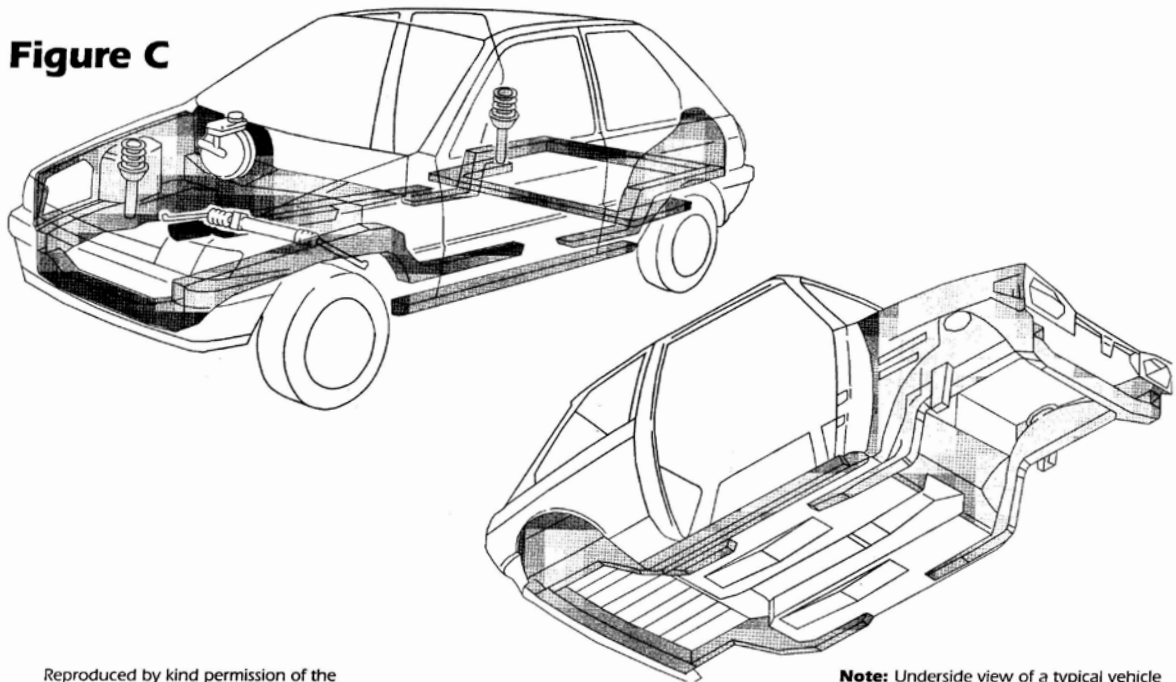

Reproduced by kind permission of the Motor Industry Repair Research Centre (M.I.R.R.C)

**Note:** Underside view of a typical vehicle monocoque construction without doors and front wings fitted.

## Structural Integrity and Corrosion

## Appendix **C**

**Figure D**

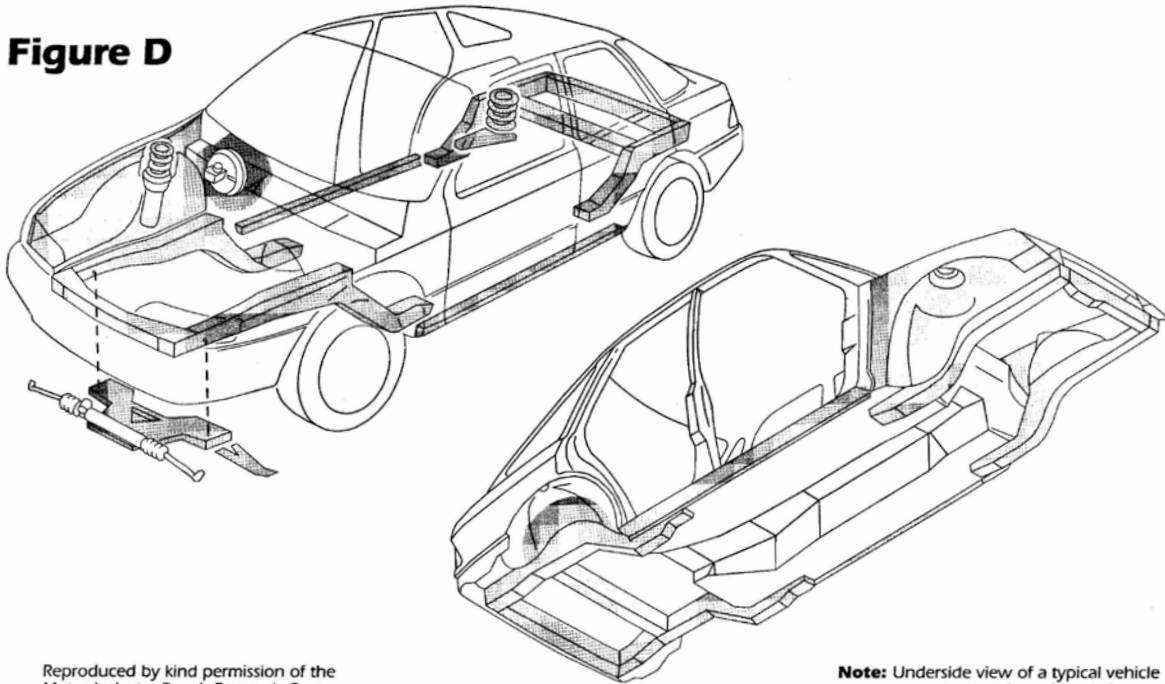

Reproduced by kind permission of the Motor Industry Repair Research Centre (M.I.R.R.C)

**Note:** Underside view of a typical vehicle monocoque construction without doors or front wings fitted.

Source: Vehicle Inspectorate. *The MOT inspection manual: car and light commercial vehicle testing*. 3rd edition. Norwich, United Kingdom, HMSO, 1996.

## Appendix 5.

# Roadblock or checkpoint management

Intercepting moving vehicles in the flow of traffic for random or specific enforcement requires the utmost attention to planning and risk assessment.

The primary consideration when setting up a checkpoint or roadblock is the safety of police officers, suspected drivers and other road users. No site should be in operation without a designated safety officer who has the responsibility of ensuring overall safety (this person may have other roles as well). Even where only two or three officers are operating, one officer should be the safety officer. Managing checkpoints includes:

### 1. Choosing a safe location

Selecting a safe location includes considering:

- locating the site where approaching drivers have sufficient time and visibility to adjust their driving in order to safely negotiate the checkpoint. If in doubt, choose another location;
- safety factors for officers when setting up and dismantling the site. Persistent bad weather can render a site impractical or unsafe;
- moving the site to multiple locations during the course of the work period to maximize the visible police presence;
- sun glare for drivers approaching the site (the sun will change its position during the course of the day);
- visibility for motorists, which is of particular concern at dusk and dawn, so extra precautions should be taken if the operation is taking place over one of those periods;
- locating night-time operations where there is effective illumination and providing additional lighting for high visibility;
- control of vehicles moving into the site as well as those vehicles passing it;
- the avoidance of unnecessary traffic congestion. Judgement as to what constitutes unreasonable congestion is subjective but, as a general rule, if the end of the traffic cannot be seen in the distance, it is time to suspend testing operations and allow it to flow until the end can be seen;
- the use of natural barriers where traffic calming is achieved, e.g. tollgates.

### 2. Slowing traffic safely

On a two- or three-lane carriageway, it is best to slow the traffic down using a funnel formation of delineation cones, a police checkpoint sign and a merge sign so that the selection and interception of vehicles can be done from a line of slow-moving traffic rather than a high-speed one. A police car with flashing lights acts as a visible

warning to approaching motorists and more importantly provides a safety corridor for officers to interview offending drivers. If the funnel method (see figure) is chosen, be aware of the traffic volume both at the time of establishment and what could be expected later. Narrowing to one lane will automatically create congestion so those not selected must be moved through quickly.

**Figure 1** Funnel method of slowing traffic (○ = safety cones)

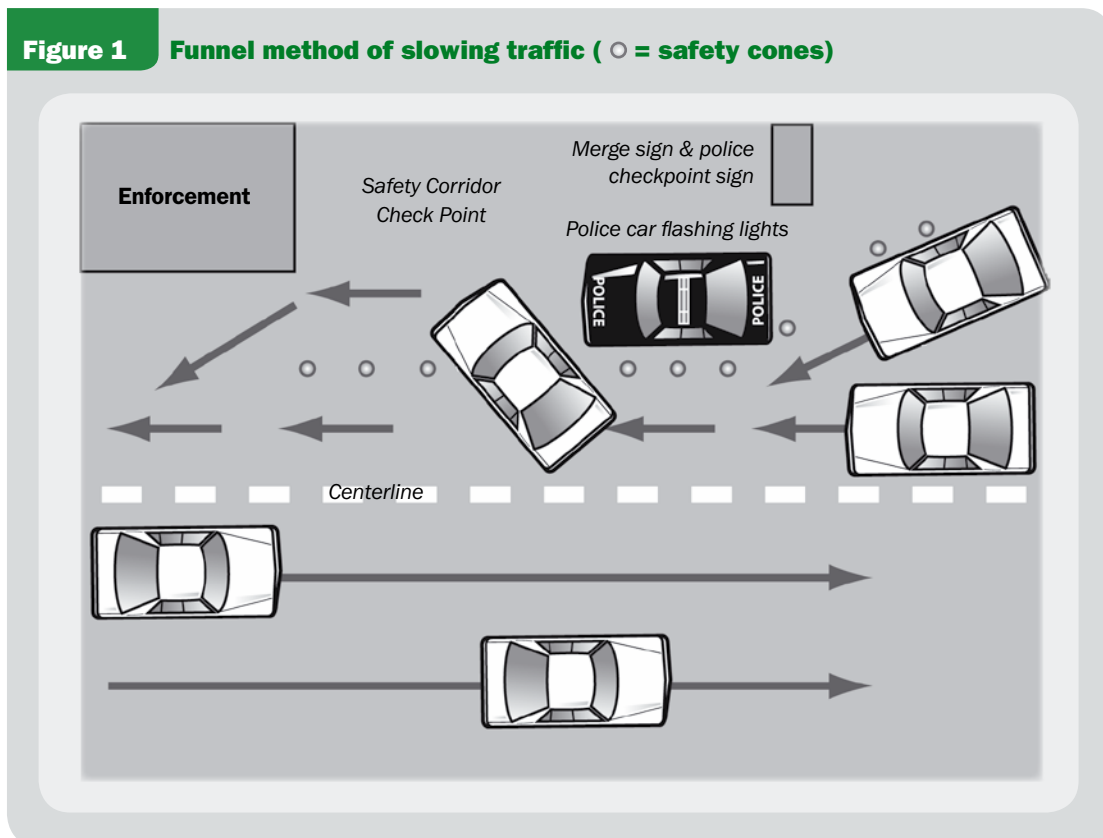

This method may create advance notice that enforcement is being undertaken. Suspected drivers may take a number of evasive actions e.g. change positions with a passenger, abandon their vehicle, attempt to drive through the checkpoint, turn left or right before the interception point, or carry out a U-turn. For these reasons it is important to have an intercept vehicle strategically placed prior to the interception point to pick up drivers attempting to evade the checkpoint or roadblock.

A team approach to the management of checkpoints is particularly beneficial where only two or three police officers are operating, for example, at a set of traffic lights where there is a safe interception point just through the intersection. One officer may stand at the traffic lights and identify drivers who stop at the red light. They can be directed by that officer to his colleague(s) undertaking the check. This system also operates successfully at tollgates. It provides a mix of visible enforcement and warnings to motorists.

### 3. Using equipment to ensure safety

Safety is paramount. The right equipment must be used properly to ensure the safety of traffic police officers and road users at all times.

- All members on site should wear reflective vests or jackets both day and night.
- All members must be in police uniform.
- Use police vehicles as traffic protection.
- Use marked police vehicles with lights flashing to maximize visibility (be conscious of the battery life with lights flashing and engine off).
- If there are any official observers, they should not be permitted on site without reflective vests.
- Equipment should include illuminated torches fitted with a red cone to provide a contrasting colour.
- Delineation of the site should be with strobe lighting or red safety cones.
- Consider if any of the surrounding equipment could be used as a safety barrier.
- Consider natural barriers or natural interception points, e.g. tollgates, service stations, parking centres, entries and exits.
- Ensure there are sufficient police numbers for a safe, effective operation.
- Ensure the operations command centre is aware of the site location.
- Consider photographic or video evidence.

### 4. Contingency planning

Ensure there is a process for dealing with:

- no licence
- no registration
- stolen vehicles
- intoxicated drivers
- refusal to stop at interception point.

While the majority of drivers will be compliant and not present any problems, there are others who may be argumentative, or who try to avoid being stopped – e.g. nervous drink drivers or criminals.

### 5. Getting the message across

The most important aspect of this method of policing is to provide a deterrent to both those being checked and drivers who pass by unchecked. Drivers passing the site should be made aware of the purpose of the checkpoint by means of either a variable message sign or large fixed sign advising “Seat-belt enforcement”. It is highly important to have a message clearly visible.

If this is not done, other drivers may assume it is an ordinary police security check or other traffic checkpoint and no change to their attitude will occur.

## **6. Processing offenders quickly**

If drivers are to be processed it should be undertaken with minimum delay to the driver. Observations should be clearly stated to the driver and corroboration from fellow officers sought if there is denial. Evidence should be recorded without argument or bargaining. Police must always be courteous and polite and maintain a high degree of skill and professionalism.

## **7. Meeting statistical requirements**

The following information should be recorded:

- number of motor vehicles that passed the site (estimated by taking a number of sample counts during the operation and multiplying the numbers for the time at the location);
- number of offenders processed;
- number of police persons involved;
- number of hours worked at the location.

## Appendix 6.

# Sample lesson plan for teaching seat-belt safety in secondary school

### In-car safety

#### **Lesson plan**

Topic of lesson: In-car safety (use of safety devices, such as seat-belts and airbags).

Length of lesson: 45 minutes (5 minutes of video).

Target audience: 12–15-year-olds.

Curriculum subject: Personal, social and health education, citizenship.

Equipment required: Television and video player.

Resources required: crash test video; seat-belt sample (a belt can be used if a seat-belt sample is unobtainable); relevant leaflets such as that highlighted in Module 4 of the manual; other leaflets outlining the current legal situation for seat-belt wearing; “7/10ths of a second” text sheet (included at end of lesson plan); national and local publicity material, such as posters, key rings etc.

Note: Some educational resources may contain project work or teaching ideas that can be incorporated into the lesson.

#### **Aims and objectives of the lesson**

- to raise pupils awareness of the dangers of irresponsible occupant behaviour;
- to highlight the consequences of non-use of in-car safety devices;
- to encourage the use of in-car safety devices;
- to highlight the benefits of using in-car safety devices.

#### **Introduction: what is the role of a safety device in a vehicle?**

Vehicle safety features fall into two categories; “primary” and “secondary” safety features. Primary safety features aim to prevent an accident taking place, e.g. good brakes, tyres. Secondary safety features aim to prevent or minimize injury to a vehicle occupant once the accident has occurred, e.g. side impact protection systems, airbags.

Seat-belts are a **secondary** safety device with a number of objectives. These include:

- preventing ejection from the vehicle in an impact;
- reducing the risk of contact with the interior of the vehicle or reducing the speed of such impacts;
- providing a distributed force to the wearer to give the necessary support in an accident, restraining the vehicle occupant before guiding them back into their seat.

The American College of Emergency Physicians (1) suggests that seat-belts are the most effective means of reducing deaths and serious injuries in traffic accidents. They also calculate that 75% of all vehicle occupants ejected from a vehicle in an accident die as a result. **Seat-belts provide the greatest protection against ejection in a crash.**

Airbags are an active, high-energy device commonly designed to act as a supplementary measure to the performance of a seat-belt. If an occupant is unrestrained, or the vehicle has an airbag installed but no seat-belt, it is possible that the occupant may come into contact with the airbag before it has fully inflated. This is also the case for people who need to sit closer to the steering wheel as a result of their size. **Airbags deploy at approximately 300 km/h. If the vehicle occupant comes into contact with the airbag before it is fully inflated, there is a real risk of the vehicle occupant sustaining serious injuries.**

**Note.** There are three collisions to every crash where occupants are unrestrained. The first collision involves the vehicle and another object (e.g. car, barrier or form of street furniture). The second collision occurs between the unbelted occupant and the vehicle interior. Finally, the third collision occurs when the internal organs of the body hit against the chest wall or the skeletal structure. Although there are many factors to consider, it is the second collision that is most responsible for injuries, and can be reduced significantly by the use of seat-belts.

In an accident travelling at 50 km/h, a vehicle occupant's body weight increases significantly (approximately 30 times). In such circumstances the weight of the occupant would be similar to that of an elephant. A seat-belt is designed to withstand such a force.

### Body of lesson

- Use leaflet containing current seat-belt wearing legislation to outline the audience's legal responsibility. If no legislation exists continue to next point.
- Discuss the effects of non-seat-belt use in a collision to outline the audience's moral responsibility.

Bring two volunteers to the front of the room and seat them one directly behind the other (about 1 metre apart). Enact the scenario of the driver travelling at 50 km/h wearing a seat-belt, and the back seat passenger in the same vehicle not wearing a seat-belt. Demonstrate that there are three movements for seat-belt wearers in an



accident: first, they move forward, and are then restrained by the seat-belt; second, they move back into their seat; third, they ride down into the seat.

For occupants not wearing a seat-belt, there is one movement; forward until they come into contact with the vehicle interior or other occupants or are thrown from the vehicle.

Reinforce that it is calculated that 75% of all vehicle occupants ejected from a vehicle in an accident die as a result. **Seat-belts provide the greatest protection against ejection in a crash.**

Demonstrate the movements of the two occupants:

- **Driver/front occupant:** moves forward, is restrained, is brought back into seat.
- **Rear occupant:** moves forward, hits the back of the driver's seat, the two heads collide, rear occupant crushes the driver between their seat and their seat-belt.
- **Likelihood:** driver/front occupant is dead.

Discuss the moral responsibility of the rear occupant to wear their seat-belt.

Show video of sample crash tests that clearly demonstrate the use of seat-belts and airbags.

Talk audience through the test. Explain that research has shown that **the simple act of buckling a seat-belt can improve an occupant's chance of surviving a potentially fatal crash by 45% to 73%.**

Reinforce the point that although airbags can be an effective restraint, reducing the severity of injury to occupants involved in an accident, they are designed to act as a supplementary measure to the performance of a seat-belt and should not be used individually.

Demonstrate correct fitting of seat-belt with the use of a seat-belt sample (a trouser belt or piece of material of similar length and thickness can be used if a seat-belt sample is not available).

- It is recommended that cars are fitted with a three-point lap and diagonal belt.
- The diagonal section should fit from the buckle, up across the centre of the chest and over the shoulder on the opposite side.
- The lap section should sit across the lap (hip bones).
- For added safety, pull upwards on the diagonal strap to minimize all slack, particularly in the lap section.
- Do not allow the lap section to position itself over the waist. In the event of an accident the strength of the hip bones will not be brought into use, and the occupant could suffer internal injuries as their body surges forward, increasing its weight to that of an elephant.
- It takes 10 seconds to fit a seat-belt. But it's 10 seconds that could save your life.

## Conclusion

The forces generated in a 50 km/h accident can increase a vehicle occupant's body weight to that of an elephant. This can be fatal for those who choose not to wear a seat-belt. It can also prove fatal for those front seat occupants who have occupants directly behind them that also do not wear a seat-belt.

There may be a legal responsibility on occupants to be appropriately restrained, but more importantly, there is a moral responsibility on all passengers to ensure that they do not kill their friends and family because of their actions. Although an occupant may die as a result of their actions, it is their family and friends who will be left suffering because of their loss.

Read "7/10ths of a second" (below). Conclude by stating that "There are 101 reasons not to wear a seat-belt. Every one is a killer." Distribute relevant promotional and educational material reinforcing the objectives of the lesson.

### BOX 1: "7/10ths of a second"

For the next 7/10ths of a second, we are going to take you through **death in slow motion**.

It's night, you're tired, and you're late getting home, so you're driving 55 miles per hour on a road not designed for that speed. Your car reaches a curve in the road, but you make a mistake, too late, the car goes out of control and you hit a solid immovable object, CRASH!!!

**1/10th of a second:** The front bumper and chrome frosting of the grillwork collapse. Slivers of steel puncture the wall to a depth of one and a half inches.

**2/10ths of a second:** The hood rises, crumples, smashes into the windshield. Spinning rear wheels leave the ground. The fenders come into contact with the wall, forcing the rear parts out over the front doors. Your body continues to move forward at 55 miles per hour – 20 times the normal force of gravity. You now weigh more than 3000 pounds. Your legs, ramrod straight, snap at the knee joints.

**3/10ths of a second:** Your body is now off the seat, torso upright, broken knees pressed against the dashboard. The plastic and steel frame of the steering wheel begins to bend beneath your death grip. Your head

is now near the sun visor, your chest above the steering column.

**4/10ths of a second:** The car's front 24 inches have been demolished, but the rear end is still travelling at about 35 miles per hour. The half-ton motor block crunches into the fire wall.

**5/10ths of a second:** Your fear-frozen hands send the steering column into an almost vertical position. The force of gravity impales you on the steering shaft. Jagged steel punctures your lungs and intercostal arteries. Blood spurts into your lungs.

**6/10ths of a second:** Your feet are ripped from your tightly laced sneakers. The brake pedal shears off the floorboards. The chassis bends in the middle. The car begins its downfall, spinning wheels digging into the ground.

**7/10ths of a second:** The entire body of the car is forced out of shape. Hinges tear, doors spring open. In one last convulsion, the seat rams forward, pinning you against the cruel steel of the steering shaft. Blood leaps from your mouth, shock has frozen your heart. YOU ARE DEAD.

Total time elapsed: **seven tenths of a second!**

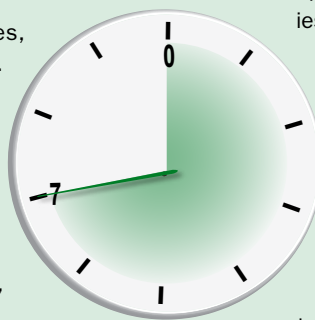

## Reference:

1. *Seat belts*. Texas, United States, American College of Emergency Physicians (ACEP), 2002 (<http://www.acep.org/patients.aspx?LinkIdentifier=id&id=26106&fid=1348&Mo=No&acepTitle=Seat%20Belt%20Fact%20Sheet>, accessed 12 November 2008).

## Partner organizations in the development of the manual

### World Health Organization (WHO)

As the United Nations specialized agency for health, the World Health Organization aims to integrate road safety into public health programmes around the world in order to reduce the unacceptably high levels of road traffic injuries. A public health approach is used, combining epidemiology, prevention and advocacy. Special emphasis is given to low- and middle-income countries where most road traffic crashes occur. In recent years WHO has focused its efforts on the implementation of the recommendations contained in the *World report on road traffic injury prevention*, which it co-produced with the World Bank, and in particular on addressing the main risk factors for road traffic injuries. Following a United Nations General Assembly resolution on road safety, adopted in 2004, WHO acts as a coordinator for road safety initiatives within the United Nations system, and to this end has facilitated the development of the United Nations Road Safety Collaboration – a group of over 40 international road safety organizations, including many United Nations agencies. This coordinating role was further endorsed by a fourth United Nations General Assembly resolution, adopted in 2005.

**Address:** World Health Organization, 20 Avenue Appia, CH-1211 Geneva 27, Switzerland

**URL:** [www.who.int/violence\\_injury\\_prevention/en/](http://www.who.int/violence_injury_prevention/en/)

**Contact person:** Margie Peden, Coordinator, Unintentional Injury Prevention, Department of Injuries and Violence Prevention

**E-mail:** [traffic@who.int](mailto:traffic@who.int)

### World Bank

The World Bank promotes the improvement of road safety outcomes in low- and middle-income countries as a global development priority, in accordance with its transport business strategy “Safe, Clean and Affordable Transport for Development 2008–2012”. It provides financial and technical support to countries, working through government agencies, nongovernmental organizations and the private sector to formulate strategies to improve road safety. The World Bank’s mission is to assist countries in accelerating their implementation of the recommendations of the *World report on road traffic injury prevention*, which it developed jointly with the World Health Organization in 2004. To achieve this, it emphasizes country capacity building and the development of related global and regional partnerships,

with a focus on the achievement of measurable road safety results. In support of this focus the World Bank Global Road Safety Facility has been established to generate increased funding and technical assistance for global, regional and country activities designed to accelerate knowledge transfer to low- and middle-income countries and catalyse increased country investment in road safety programmes.

**Address:** World Bank, 1818 H Street, NW, Washington DC 20433, United States

**URL:** <http://www.worldbank.org/grsf>

**Contact person:** Anthony Bliss, Lead Road Safety Specialist, Transport Division, Energy, Transport and Water Department

**E-mail:** [abliss@worldbank.org](mailto:abliss@worldbank.org)

### **Global Road Safety Partnership (GRSP)**

The Global Road Safety Partnership is a partnership between business, civil society and government dedicated to the sustainable reduction of death and injury on the roads in developing and transition countries. By creating and strengthening links between partners, GRSP aims to increase awareness of road safety as an issue affecting all sectors of society. GRSP seeks to establish sustainable partnerships and to deliver road safety interventions through increased resources, better coordination, management, greater innovation and knowledge sharing, both globally and locally.

GRSP is a hosted programme of the International Federation of Red Cross and Red Crescent Societies.

**Address:** Global Road Safety Partnership, c/o International Federation of Red Cross and Red Crescent Societies, PO Box 372, 17 Chemin des Crêts, CH-1211 Geneva 19, Switzerland

**URL:** [www.grsproadsafety.org](http://www.grsproadsafety.org)

**Contact person:** Andrew Pearce, Chief Executive

**E-mail:** [grsp@ifrc.org](mailto:grsp@ifrc.org)

### **FIA Foundation for the Automobile and Society**

The FIA Foundation for the Automobile and Society is a registered United Kingdom charity with the objectives of promoting public safety and public health, the protection and preservation of human life, and the conservation, protection and improvement of the physical and natural environment. Since its establishment in 2001, the FIA Foundation has become a prominent player in promoting road safety around the world. It conducts advocacy to raise awareness about the growing epidemic of road traffic injuries and place road safety on the international political agenda. It promotes research and the dissemination of results to encourage best

practice in road safety policy, and offers financial support to third-party projects through a grants programme.

**Address:** FIA Foundation, 60 Trafalgar Square, London WC2N 5DS,  
United Kingdom

**URL:** [www.fiafoundation.org](http://www.fiafoundation.org)

**Contact person:** David Ward, Director General

**E-mail:** [mail@fiafoundation.org](mailto:mail@fiafoundation.org)

## Glossary of terms

**airbag.** Safety device installed in a vehicle that inflates to protect the driver or passengers in case of a collision. Most airbags are fitted in the driver and right passenger positions, but some newer cars also contain side airbags.

**attachment.** Part of the seat-belt assembly including the necessary securing components that enable it to be attached to the seat-belt anchorages.

**belt adjusting device.** A device enabling the seat-belt to be adjusted according to the requirements of the individual wearer and to the position of the seat. The adjusting device may be part of the buckle, or a retractor, or any other part of the seat-belt.

**booster seat.** A seat that boosts a child up, providing a higher sitting height in the vehicle, which allows the adult seat-belt to fit properly.

**buckle.** A quick-release device enabling the wearer to be held by the seat-belt, securing the open end of the seat-belt to the floor mounting by means of a tongue.

**Centers for Disease Control and Prevention (CDC).** The CDC includes the National Center for Injury Prevention and Control, which has a focus on preventing motor vehicle-related injury through research and programmes. It is the principle prevention agency of the United States Department of Health and Human Services, located in Atlanta, Georgia.

**change in velocity during a collision ( $\Delta V$ ).** In crash reconstructions, the change in velocity occurring as a result of an impact – usually at the centre of gravity of the vehicle – is widely used as the measure of the severity of a collision. At high speeds, collisions between cars are almost totally inelastic and so there is very little rebound. Thus if a car travelling at 100 km/h strikes a stationary car of the same mass, they will both undergo a change in velocity of 50 km/h.

**child restraint.** An infant seat (for under 1 year of age) or child safety seat (for 1–4 years of age) designed according to the age and weight of the child, offering protection in the event of a car crash.

**cost.** Use of resources that have alternative uses. Costs are generally measured in monetary terms, but the concept of cost includes any use of resources, not just direct out-of-pocket expenses.

**cost–benefit analysis.** A formal analysis of costs and benefits of a programme, in which all relevant impacts are converted to monetary terms (*I*).

**diagonal belt.** A seat-belt that passes diagonally across the front of the chest from the hip to the opposite shoulder.

**emergency medical services (EMS).** The services provided by trained personnel using adequate equipment soon after an emergency. EMS for injuries aim to reduce

the rates of death from potentially life-threatening injuries. These services include the care provided before the person reaches the hospital (pre-hospital EMS, including care delivered in the field and transport to a fixed site of definitive care) and the medical care provided in a hospital-based setting.

**evaluation.** An ongoing process to assess the effectiveness of a programme in achieving its objectives. Evaluation also aims to identify problems that may arise with the implementation of a programme, so that concerns are fed back into the planning process and modifications can be carried out during the implementation. An evaluation is usually designed to try to distinguish the effects of a programme from those of other factors.

**FIA Foundation for the Automobile and Society.** Established by the Fédération Internationale de l'Automobile (FIA) in 2002 as a registered charity in the United Kingdom, the FIA Foundation is a leader in global road safety advocacy and a major supporter of road safety research, working closely with international partners to promote road safety and a sustainable approach to mobility.

**first aid.** Emergency treatment administered to an injured person at or near the injury site, prior to receiving professional medical care.

**full harness belt.** A seat-belt assembly comprising lap, thigh and shoulder straps with a central locking device.

**Global Road Safety Partnership (GRSP).** A global partnership involving business, civil society and governments dedicated to the sustainable improvement of road safety in developing and transition countries.

**high-income country.** For the purpose of this document the World Bank classification has been used to classify countries, based on gross national income (GNI) per capita. A high-income country is one whose GNI per capita is US\$ 9076 or more (2).

**high-visibility law enforcement.** Patrolling by the police that is easily seen by passing road users, for example random alcohol and sobriety checkpoints.

**human capital approach in costing road crashes.** This approach is based on human capital theory, which focuses on the centrality of human beings in the production and consumption system. The human capital approach model includes both direct and indirect costs to individuals and society as a whole due to road traffic injuries. Such costs include emergency treatment, initial medical costs, rehabilitation costs, long-term care and treatment, insurance administration expenses, legal costs, workplace costs, lost productivity, property damage, travel delay, psychosocial impact and loss of functional capacity (3).

**integrity of the passenger compartment.** Ability of a vehicle's passenger compartment to stay whole and not collapse on impact with another vehicle or object.

**ISOFIX.** An international standard attachment that child restraints can be connected to, with the objective of reducing the likelihood of incorrect fitting and making restraint removal and fitting easy for the vehicle user.

**key performance indicator (KPI).** An indicator against which specific items or services can be compared as a measure of how closely they meet the stated requirement.

**lap and shoulder belt.** *See three-point lap and diagonal seat-belt.*

**lap belt.** *See two-point lap belt.*

**legislation.** Acts or provisions that have the force of law, i.e. that give the police the right to enforce their provisions and the courts of law the right to impose penalties (1).

**low-income country.** For the purpose of this document the World Bank classification has been used to classify countries, based on gross national income (GNI) per capita. A low-income country is one whose GNI per capita is US\$ 735 or less (2).

**middle-income country.** For the purpose of this document the World Bank classification has been used to classify countries, based on gross national income (GNI) per capita. A middle-income country is one whose GNI per capita is between US\$ 736 and US\$ 9075 (2).

**offset deformable barrier test.** A frontal crash test that aims to reproduce real-world conditions of car-to-car frontal crashes. In this test, the front of the striking vehicle partially overlaps a deformable barrier.

**Organisation for Economic Co-operation and Development (OECD).** The OECD brings together countries sharing the principles of the market economy, pluralist democracy and respect for human rights.

**out-of-position occupant.** A vehicle driver or passenger who is out of his or her seating position at the time of the crash – for example, a child lying across the rear seat.

**passenger airbag.** *See airbag.*

**passive safety device.** Any device that automatically provides protection for the occupant of a vehicle, such as seat-belts, padded dashboard, bumpers, laminated windshield, head restraints, collapsible steering columns and airbags.

**pre-hospital care.** The care provided to reduce the effects of trauma or injury before the injured person reaches a hospital-based setting (*see emergency medical services*). This includes the formal response provided by trained and equipped personnel, as well as the bystanders' response provided by lay people.

**pretensioner.** An additional or integrated device that tightens the seat-belt webbing in order to reduce the slack of the seat-belt during a crash.



**release mechanism.** A red-coloured push button device that, when pressed, releases the tongue from the buckle of the seat-belt.

**retractor.** Device to accommodate part or all of the strap of a seat-belt.

**risk.** The possibility of an unwanted event occurring.

**risk factor.** A factor that affects the probability of an unwanted event occurring or influences the severity of the consequences that arise as a result of the event.

**road traffic crash.** A collision or incident that may or may not lead to injury, occurring on a public road and involving at least one moving vehicle.

**road traffic fatality.** A death occurring within 30 days of a road traffic crash (3).

**road traffic injury.** Non-fatal injury incurred as a result of a road traffic crash.

**road user.** A person using any part of the road system as a non-motorized or motorized transport user.

**safety performance standard.** Definition or specification for equipment or vehicle performance that provides improved safety. Such standards are produced nationally, regionally or internationally by a variety of organizations.

**seat-belt.** A seat-belt, sometimes called a safety belt, is a safety harness designed to secure the occupant of a vehicle against harmful movement that may result from a collision or a sudden stop. Seat-belts are intended to reduce injuries by stopping the wearer from hitting hard interior elements of the vehicle or other passengers and by preventing ejection from the vehicle.

**seat-belt anchorage.** A point in the vehicle to which a seat-belt is attached.

**seat-belt reminder system.** Intelligent visual or audible device that detects whether or not seat-belts are in use in different seating positions and gives out increasingly aggressive warning signals until the seat-belts are used. The signal may be a buzzer, chime or voice reminder.

**submarining.** During a collision, sliding of the occupant under the seat-belt into the foot well compartment as a result of too much slack in a seat-belt assembly.

**surveillance.** Systematic ongoing collection, collation and analysis of data and the timely dissemination of information to those who need to know so that action can be taken.

**three-point lap and diagonal seat-belt.** Any seat-belt that is essentially a combination of a lap strap fitting over the pelvis and a diagonal strap that fits over the shoulder. A three-point lap and diagonal seat-belt is much safer than a lap belt or shoulder belt alone.

**tongue.** A metal insert connected to the seat-belt and fastening into the buckle, only disconnected by pressing the release mechanism.

**Transport Research Laboratory (TRL).** An independent, internationally recognized centre of excellence in surface transport issues.

**two-point lap belt.** A seat-belt that passes across the front of the wearer's pelvic region.

**United Nations Economic Commission for Europe (UNECE).** The UNECE strives to foster sustainable economic growth among its 55 member countries. It provides a forum for communication between States; brokers international legal instruments addressing trade, transport and the environment; and supplies statistics and economic and environmental analysis. It includes the World Forum for Harmonization of Vehicle Regulations (WP29).

**United Nations Road Safety Collaboration.** Established after the passing of United Nations resolution 58/289, it brings together over 42 organizations to share their experiences and expertise on road safety.

**webbing.** The strap section of the seat-belt system used to counteract the momentum of the vehicle occupant in the rapid deceleration experienced in a crash.

**World Bank.** A development bank that provides loans, policy advice, technical assistance and knowledge-sharing services to low- and middle-income countries to reduce poverty. The Bank's mission is to fight poverty and improve the living standards of people in the developing world.

**World Health Organization (WHO).** The United Nations specialized agency for health, headquartered in Geneva, Switzerland.

## References

1. Elvik R, Vaa T. *The handbook of road safety measures*. Amsterdam, the Netherlands, Elsevier, 2004.
2. Country classification: classification of economies. Washington DC, World Bank Group, 2002 ([www.worldbank.org/data/countryclass/countryclass.html](http://www.worldbank.org/data/countryclass/countryclass.html), accessed 12 November 2008).
3. Economic Commission for Europe Intersecretariat Working Group on Transport Statistics. *Glossary of transport statistics*, 3rd ed. TRANS/WP.6/2003/6. New York, United Nations Economic and Social Council, 2003 (<http://www.unece.org/trans/main/wp6/pdfdocs/glossen3.pdf>, accessed 12 November 2008).